

LOAD KING



OPERATOR'S MANUAL OUTBACK OUTBACK 35-48DR

WARNING: Operating, servicing and maintaining this equipment can expose you to chemicals including engine exhaust, carbon monoxide, phthalates, and lead, which are known to the State of California to cause cancer and birth defects or other reproductive harm. These chemicals can be emitted from or contained in other various parts and systems, fluids and some component wear by-products. To minimize exposure, avoid breathing exhaust, do not idle the engine except as necessary, service your equipment and vehicle in a well-ventilated area and wear gloves or wash your hands frequently when servicing your equipment or vehicle and after operation. For more information go to www.P65Warnings.ca.gov/passenger-vehicle.

Breathing diesel engine exhaust exposes you to chemicals known to the State of California to cause cancer and birth defects or other reproductive harm.

- Always start and operate the engine in a well-ventilated area.
- If in an enclosed area, vent the exhaust to the outside.
- Do not modify or tamper with the exhaust system.
- Do not idle the engine except as necessary.

For more information go to www.P65warnings.ca.gov/diesel.

PAGE INTENTIONALLY LEFT BLANK

Table of Contents

Introduction	7
About Custom Truck One Source	7
Construction and Industrial Equipment Product Safety	8
Nomenclature	9
Intended Use	10
Bulletin Distribution and Compliance	10
Contacting the Manufacturer	10
Limited Product Warranty	11
Load King Warranty Data Record	12
Specifications	13
Features	13
Machine Measurements	14
Outrigger Spread	15
Ground Penetration	16
Safety	19
Owners, Users, and Operators	19
Safety Definitions Used in This Manual	20
Safety Guidelines	21
Personal Protection Equipment	21
General Safety/Operation Guidelines	22
Safety Precautions	23
Description of Machine	25
Machine Component Identification	25
Grease Fitting Locations	29
Auger Drive Assembly	30
Outback 35-48DR Engine Information	31
Single Bucket Arm Adapter	32
Dual Bucket Adapter	33
Dual Bucket Pin Location	34
Pole Claw	34
Can Handler	35
Material Handler	35
Operating Instructions	37

Starting Instructions	37
Accessory Instructions.....	60
Wireless Radio Remote	60
Technical Information.....	61
Operating Environments	63
Transportation65
Unloading Machine from Trailer	65
Loading Machine from Trailer	66
Maintenance67
General	67
Adjustments	68
Track Drive Motor	70
Boom Maintenance	71
Maintenance Issues with Fiberglass Booms	72
Checklist and Inspection Forms.....	.75
Machine Inspection Chart.....	75



Introduction

Load King has been producing first-class heavy equipment since 1956. Cutting-edge innovation and engineering excellence make us the market leader. **Load King** is a key part of the Custom Truck One Source family of brands, offering standard and custom trailers, vocational equipment, and a full line of boom trucks and outback machines. For more information, please visit **Load King's** website: www.loadkingmfg.com

About Custom Truck One Source

Custom Truck One Source is the first true single-source provider of specialized truck and heavy equipment solutions. With sales, rentals, aftermarket parts and services, equipment customization, re-manufacturing, financing solutions, and asset disposal; our team of experts, vast equipment breadth and integrated network of locations across North America offer superior service and unmatched efficiency for our customers.

35-48DR

Introduction

Construction and Industrial Equipment Product Safety

Construction and Industrial Equipment Product Safety

It is the responsibility of the owner of the equipment to be knowledgeable about federal, state and local regulations that effect the total usage of the equipment, and responsibility to working personnel and the public. Since regulations are subject to change, and differ from one locality to another, this manual makes no attempt to provide such information.

Load King provides appropriate operation and maintenance manuals for various construction and industrial equipment products that it manufactures and sells. Appropriate national consensus standards, industry standards, and safety-related manuals are included with the shipment of each **Load King** product as applicable. It is company policy to provide this information for the owner or Operator of the equipment. It is expected that the Owner or Operator will utilize these manuals and standards to provide the appropriate information and training to those people who are to operate, maintain, and supervise the use of equipment.

Construction and industrial equipment is designed and manufactured to perform heavy-duty work. Under normal usage, the equipment will wear. For this reason it is essential that the Owner/Operator establish and perform a periodic inspection of the equipment. The objective of inspection programs is to prevent accidents, reduce downtime and keep the equipment working efficiently. These inspection programs should be designed to discover worn, cracked, broken or deteriorated parts and loose or missing fasteners before they result in a problem.

Proper training and inspection programs are essential to avoid injuries to persons, damage to property and excessive maintenance costs.

Read and understand the manuals provided with this equipment. Assistance is available from the distributors of your **Load King** product and from the **Load King** manufacturing facility.



When operating a hydraulic Outback, the Operator should realize that hydraulic and structural competence, not tipping load, is often the determinant of lifting capacity. The Operator must be guided solely by the appropriate manufacturer's load rating chart when considering load weights. The manufacturers rated loads must never be exceeded.

For any additional information regarding the care and operation of the machine, contact the **Load King** service representative. Include the machine model and serial number in all communication to aid service personnel in providing the correct information.

The information, specifications, and illustrations in this publication are based on the information in effect at the time of approval for printing. **Load King** reserves the right to make changes at any time without obligation.

Nomenclature

The Operator should not attempt to operate the machine before he has gained a thorough understanding of the material presented in the following pages. To aid in understanding the contents of this manual, the following terms will always have the meanings given whenever they are used.

1. Boom
2. Turret
3. Valve Frame Assembly
4. Outriggers
5. 20 Gallon Fuel Tank
6. Track Chassis and Undercarrage
7. Slab Assembly
8. Auger Drive Assembly
9. Engine
10. Hydraulic Tank

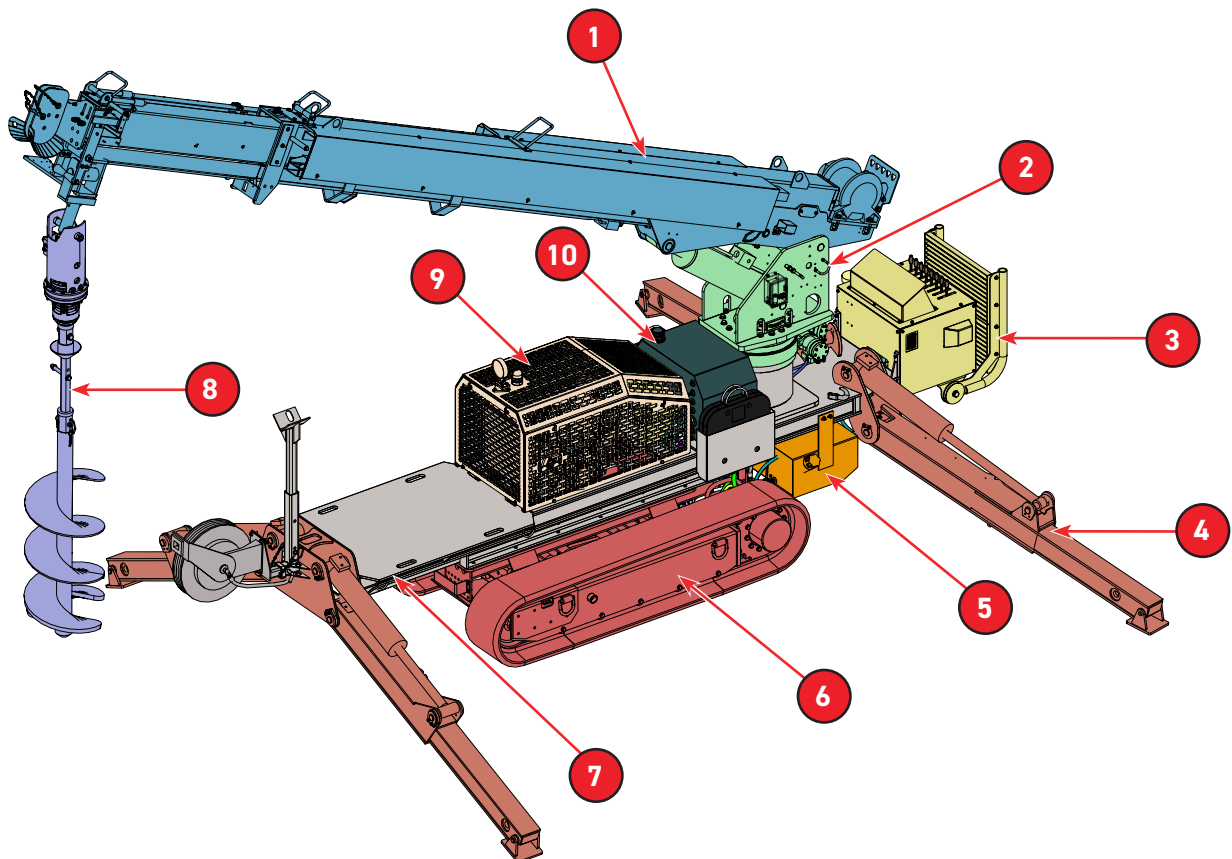

35-48DR

Introduction

Intended Use

Intended Use

This **Load King** Outback 35-48DR is designed to lift, lower, move, and position freely-suspended loads within its rated capacity while on firm, level ground. The machine is designed exclusively for assembly type, non-duty cycle operations. Use of this product in any other way is prohibited and contrary to its intended use. Other applications outside of the intended use statement above must be approved in writing by **Load King**.

This manual is intended for authorized personnel and users who have experience with **Load King** equipment. It is the Operator's responsibility to read and understand this manual before operating the **Load King** Outback 35-48DR.

Bulletin Distribution and Compliance

Safety of product users is of paramount importance to **Load King**. Various service bulletins are used by **Load King** to communicate important safety and product information to dealers and machine owners. The information contained in these service bulletins is tied to specific machines using the machine's model number and serial number. Distribution of service bulletins is based on the most current owner on record, along with the associated dealer. It is important to register the machine and keep contact information up to date. To ensure the safety of personnel and the reliable continued operation of the machine, it is essential to implement the actions indicated in all relevant service bulletins.

Contacting the Manufacturer

When it is necessary to contact the manufacturer, please be prepared to supply the model name, and serial number of the machine, along with your name and contact information. At minimum, the manufacturer should be contacted for:

- Accident reporting
- Questions regarding product applications and safety
- Standards and regulations compliance information
- Questions regarding product modifications

Manufacturer contact information:

Custom Truck One Source

7701 Independence Ave.

Kansas City, MO 64125

Parts: (816) 241- 8387

Service: (833) 281-7911

info@customtruck.com

<https://store.loadkingmfg.com>

Limited Product Warranty

Load King LLC provides a ONE (1) year limited warranty on the entire machine.

Load King LLC provides a TWO (2) year limited warranty on Load King manufactured components. (Parts built and manufactured by Load King only)

Products designed and manufactured by Load King, Incorporated, are warranted to be free from defects in material and workmanship at the time of initial delivery subject to the following provisions:

For one (1) year following initial delivery of the product, Load King will, at its option, repair or replace any part found by Load King to be defective in material or workmanship. The customer is obligated to contact Load King, Inc. prior to any work being performed on equipment. A completed Load King Warranty Claim Form is required within thirty (30) days of the date of failure of any warranted part. Load King will inspect defective parts for approval prior to issuing credit to the customer. Defective parts shall be shipped to the factory pre-paid motor freight or UPS within 30 days of failure of any warranted part if factory requests return of said parts.

The Load King limited warranty does not cover: (a) products which have not been operated and maintained in accordance with Load King operators and maintenance schedules, programs, or bulletins; (b) products which have not been mounted in accordance with Load King installation procedures; (c) products not manufactured by Load King which are supplied by Load King (d) products which are repaired without using original Load King parts; or (e) transportation or delivery to a Load King service facility or the customer's location.

The battery, generator, hydraulic components, electrical components, drive motors, and or other parts/ equipment, but not limited to, not manufactured by Load King is subject to warranty guidelines set forth by the respective manufacturers and their allowed warranty period. Such warranties shall be handled direct through the respective manufacturer or one of its distributors.

This warranty is in lieu of any other warranties, express or implied. There is no warranty of merchantability or fitness for a particular purpose, nor is there any other warranty, express or implied, except as specifically stated herein. No associate, agent or representative of Load King is authorized to extend any warranty on Load King's behalf. Load King shall in no event be liable for any special, indirect, or consequential damages or claims of any third party against the Customer.

WARRANTY CLAIMS WILL NOT BE PROCESSED UNLESS THERE HAS BEEN PRIOR APPROVAL FROM THE FACTORY FOR THE REPAIR WORK THAT IS TO BE PERFORMED. (THIS EXCLUDES TRAVEL TIME AND OR MILEAGE WHICH IS NOT ALLOWED OR COVERED UNDER THE LOAD KING LIMITED WARRANTY.) NO EXCEPTIONS WILL BE MADE.

35-48DR

Introduction

Load King Warranty Data Record

Load King Warranty Data Record

Warranty Form Submission		Date	
Date of Delivery			
Model Number			
S/N			
Dealer			
Address			
Customer			
Address			

Record this information at the time that warranty registration form is completed and returned to **Load King**.

Specifications

The Outback 35-48DR is a compact, rubber-tracked digger derrick designed for backyard work, offering a sheave height of up to 40-48 feet and a lifting capacity of 6,000 lbs. Built to navigate tight spaces and rough terrain, this compact digger reaches jobsites that standard utility trucks can't access. With 10,500 ft.-lbs. of auger digging torque, the Outback is equipped to handle tough conditions and help get the job done efficiently.



Features

Weight 12,300 lbs.

Length 20'-2.62".

Width 35 in. Closed/51 in. Open

Digging Radius 24 ft.

Winch Capacity 6,000 lbs.

Sheave Height 40/48 ft.

Side Reach 35 ft.

Tracks 90 in. Rubber

35-48DR

Specifications
Machine Measurements

Machine Measurements

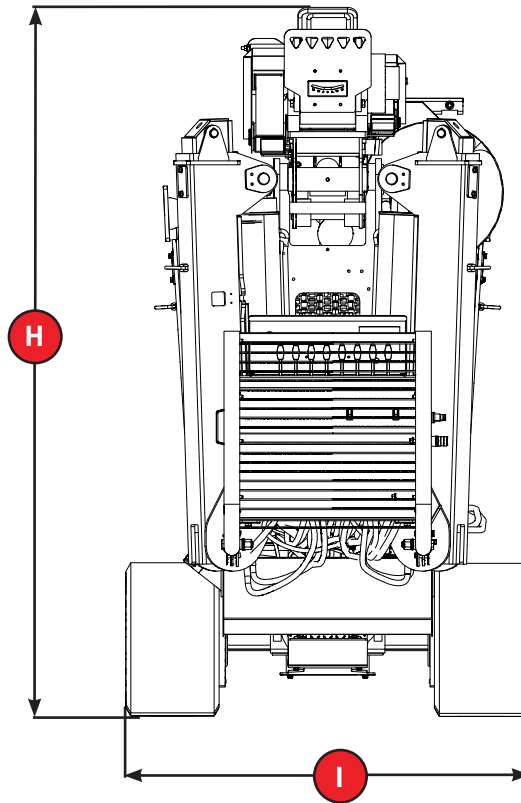
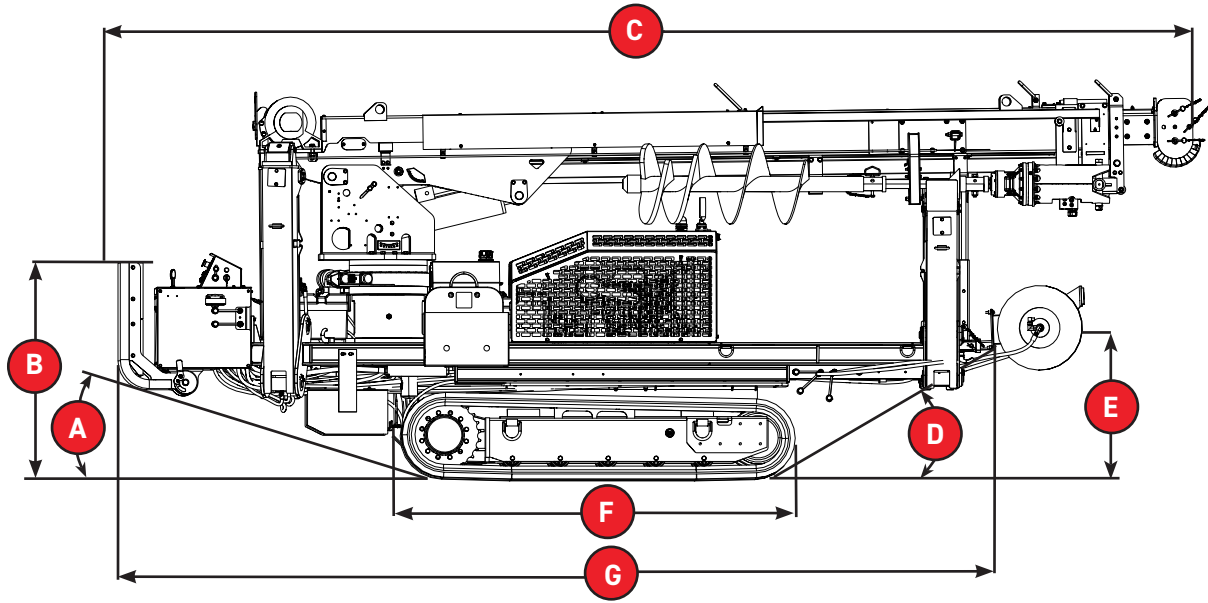

Outrigger Spread

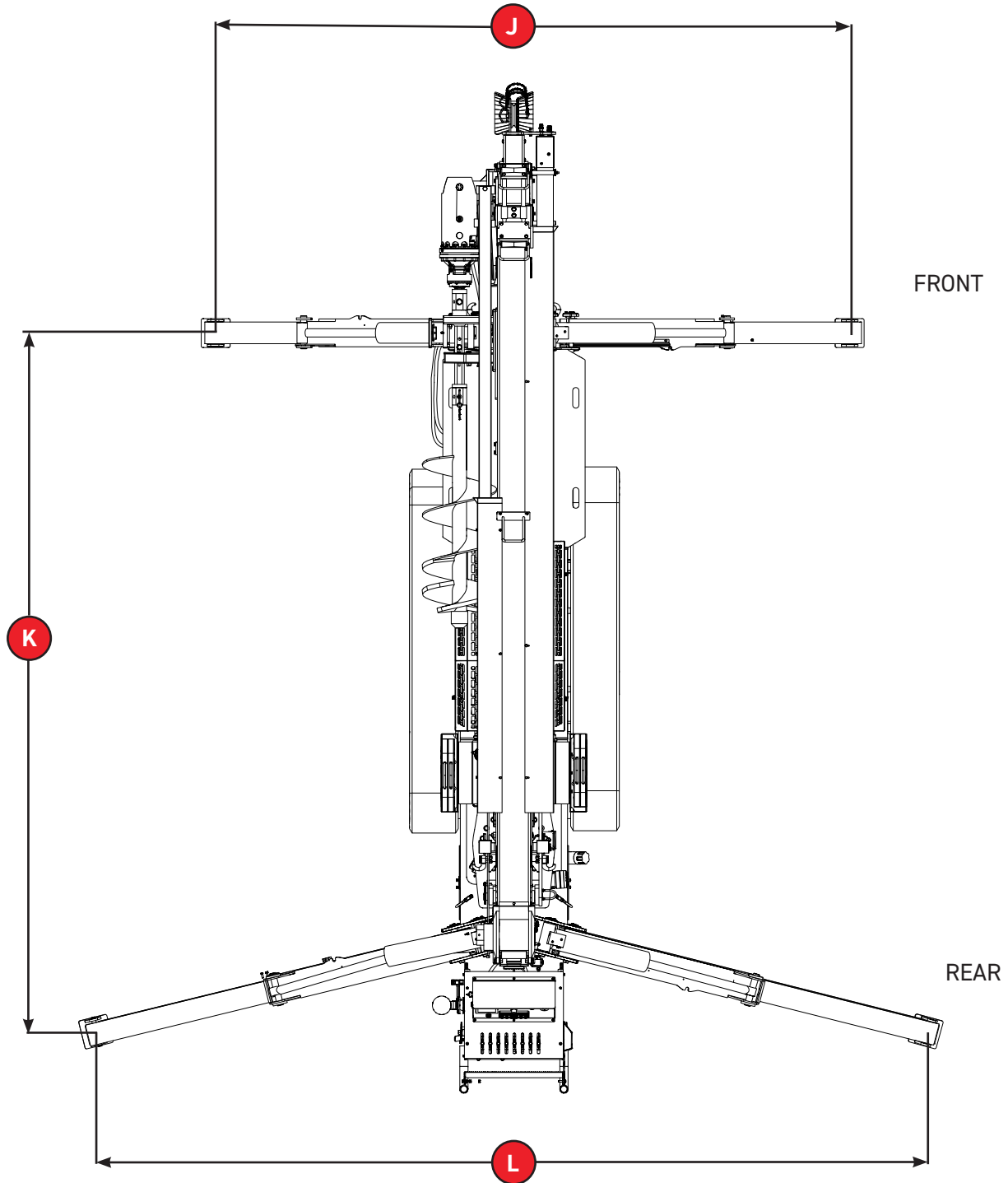

35-48DR

Specifications
Ground Penetration

Ground Penetration

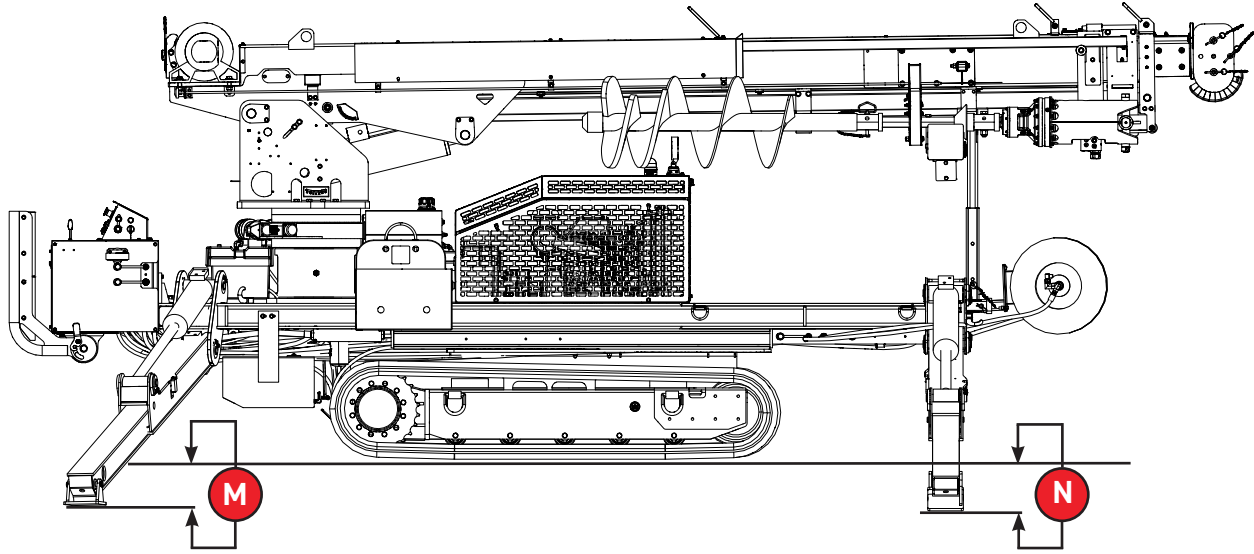



All dimensions listed are approximate. If exact dimensions are required, contact your **Load King** service representative.

Reference Letter	Dimensions
A	20°
B	3'-9" Control Height
C	20'-2.6"
D	25°
E	2'-5" Ground To Bed Height
F	7'-3" Chassis Length
G	15'-2" Frame Length
H	7'-4"
I	2'-11" Closed 4'-2" Open
J	144"
K	14'-8"
L	15'-8"
M	8"
N	1'

PAGE INTENTIONALLY LEFT BLANK

Safety

Owners, Users, and Operators

Load King appreciates your choice of our machine for your application. Our number one priority is user safety, which is best achieved by our joint efforts. We feel that you make a major contribution to safety if you, as the equipment users and Operators:

- Comply with OSHA, federal, state, and local regulations.
- Read, understand, and follow the instructions in this and other manuals supplied with this machine.
- Follow safe work practices.
- Only have trained and competent Operators, directed by informed and knowledgeable supervision, running the machine.



OSHA prohibits the alteration or modification of the machine without written manufacturer's approval. Use only factory-approved parts to service or repair this unit.

If there is anything in this manual that is not clear or you believe should be added, please send your comments to **Load King** Cranes, 7701 Independence Ave, Kansas City, MO 64125; or contact us by telephone at Parts: (816) 241- 8387 Service: (833) 281-7911.

Email: info@loadkingmfg.com

Many aspects of crane operation and testing are discussed in standards published by the American National Standards Institute. These standards are updated on an annual basis with addenda, that are sent by ASME to the original purchasers of the standard. **Load King** recommends owners purchase and refer to the following standards.

ANSI/ASME B30.5 - Mobile and Locomotive Crane (latest version)

These standards can be purchased from:

American Society of Mechanical Engineers
Two Park Avenue
New York, NY 10016-5990
800-843-2763 (U.S./Canada)
001-800-843-2763 (Mexico)
973-882-1170 (outside North America)

Email:
CustomerCare@asme.org
www.asme.org





35-48DR

Safety

Safety Definitions Used in This Manual

Safety Definitions Used in This Manual

The following table describes text and symbols used to highlight important information.

Signal Word	Symbol	Explanation
DANGER		Danger indicates a hazardous situation which, if not avoided, will result in death or serious injury.
WARNING		Warning indicates a hazardous situation which, if not avoided, could result in death or serious injury.
CAUTION		Caution indicates a hazardous situation which, if not avoided, could result in minor or moderate injury.
READ		Read is used to alert readers of information to be read on machinery.
NOTE		Note is used for a tip or suggestion to help readers carry out a procedure successfully.

Safety Guidelines



These safety rules must be followed. All personnel are required to read and understand the Operator's Manual as there are instructions which are detailed specific to this machine.

Personal Protection Equipment

Before beginning operation, service, or maintenance, conduct a hazard assessment to determine appropriate personal protective equipment for the working conditions and the operating environment. For more information refer to the applicable OSHA 1910.132 standards, ANSI standards, federal, state, local, and job site regulations.

Common Types of PPE



Safety Glasses – Impact resistant lenses offering limited protection for the user's eyes from flying debris.



Ear Plugs – A device that is inserted into the ear canal to protect the user's hearing from loud noises or the intrusion of foreign bodies and dust.



Hard Hat – A helmet used to protect the user's head from injuries obtained from falling objects and debris.



Leather Gloves – Gloves used to protect the user's hands from minor cuts and other injuries.



Safety Boots – Boots designed to protect the user's feet from various types of injury such as cuts, puncture wounds, or crushed toes.

35-48DR

Safety

General Safety/Operation Guidelines

General Safety/Operation Guidelines

The following instructions are to be followed for proper operation of the **Load King** Outback 35-48DR.

Load King recommends any Operators to be trained prior to operating the machine. Training can be arranged through your distributor or directly through **Load King**. Training can be arranged through your distributor or directly through **Load King**.

- **Load King** has no direct control over machine application, operation, inspection, lubrication or maintenance. The use of the **Load King** Outback 35-48DR is subject to certain potential dangers that cannot be protected. Therefore, it is the Operator's responsibility to use good safety practices in these areas.
- Modifications to this **Load King** Outback 35-48DR from the original design specifications without written consent from **Load King** are strictly forbidden. Any modifications will void the **Load King** factory warranty.



Modifications may compromise the safety of the **Load King** Outback 35-48DR, which could lead to serious injury or death.

- Do not exceed the rated load capacity of the **Load King** Outback 35-48DR. Know the weight of the object that is to be handled. Stay within work zones shown on the load charts.
- Do not operate the **Load King** Outback 35-48DR if any interlock or safety device is malfunctioning or has been tampered with.
- Do not operate the **Load King** Outback 35-48DR if it is not functioning properly, making unusual noises or if there are any fluid leaks.
- Perform all daily and scheduled maintenance.
- Do not put a side load onto the machine. Maneuver boom assembly over object that is to be lifted.
- When transporting the Outback 35-48DR, use designated tie down points on the machine to secure it to the trailer. Use the straps and winches provided with the machine.
- Always store attachments in correct location. When possible, secure attachments to machine's trailer during transportation.
- Inspect winch line daily. Do not tie winch lines together.
- Do not operate the boom assembly on trailer.
- Boom stows are to be lowered/pivoted out of the way before boom operation.
- Use the provided pins for all pinning locations. Bolts with threads contacting any fiberglass or other pinned surface may damage the component. This damage is not covered under warranty.
- Do not walk beneath hoisted loads.

Safety Precautions

EVERY TRACK UNIT HAS INHERENT DANGERS ASSOCIATED WITH IT.

For Your Safety:

- Keep all guards and shields in place. Moving parts can crush and dismember.
- Check that all connections and bolts are tight before operating.
- Check all hoses and fittings before start-up and periodically during operation.
- Clear the area before equipment start up.
- Do not allow bystanders near the operating unit.
- Keep hands, feet, and loose clothing away from operating track unit. Exposed, moving parts can crush or dismember.
- Use caution when traveling over uneven terrain and when approaching stops.

THERE ARE ADDITIONAL HAZARDS ASSOCIATED WITH THE SERVICE AND MAINTENANCE OF A TRACK UNIT.

For Your Safety:

- Always wear eye protection when operating or servicing the unit.
- Do not depend on hydraulic pressure applied to blades or backhoe to elevate machine for track unit service. Always service track units and undercarriage from outside or from above the unit rather than from underneath.
- Escaping hydraulic fluid under pressure can penetrate the skin and cause serious injury. Relieve all pressure from the hydraulic system before connecting or disconnecting the lines or making repairs.
- Never make any alterations or modifications to this equipment.



NEVER ATTEMPT TO CLEAN, OIL, OR ADJUST A MACHINE IN MOTION.

PAGE INTENTIONALLY LEFT BLANK

35-48DR

Description of Machine
Machine Component Identification



Description of Machine

Machine Component Identification

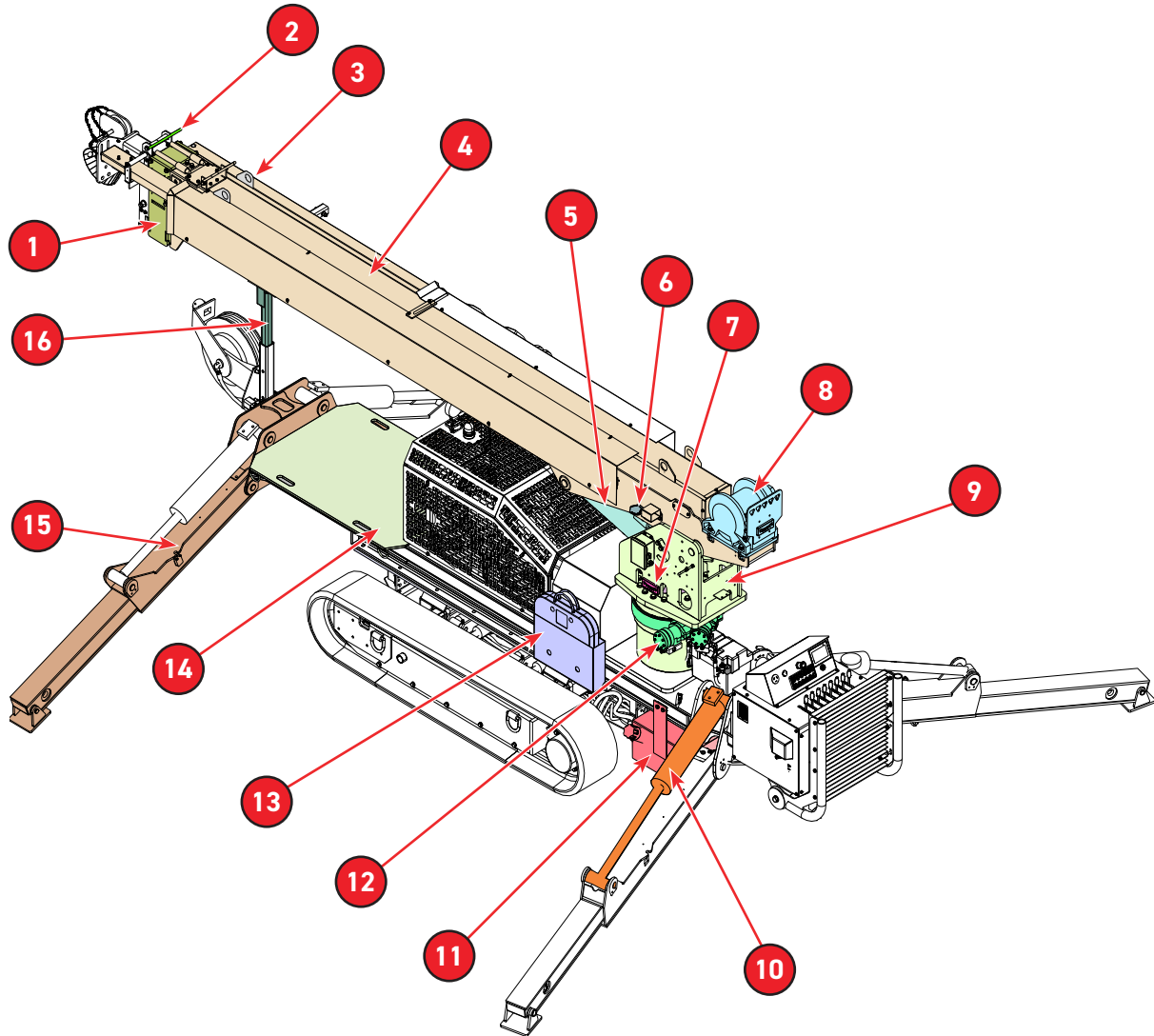

1	Auger Hanger	9	Turret
2	Winch Rope Guides	10	Outrigger Cylinders (Left and Right, Front and Back)
3	Boom Eyelet	11	Fuel Tank
4	Main Boom	12	Rotation Gear
5	Lift Cylinder	13	Outrigger Pads
6	Boom Angle Indicator	14	Storage Bed
7	Machine Level Indicator	15	Outrigger Legs (Left and Right, Front and Back)
8	Winch	16	Boom Stow

35-48DR

Description of Machine

Machine Component Identification

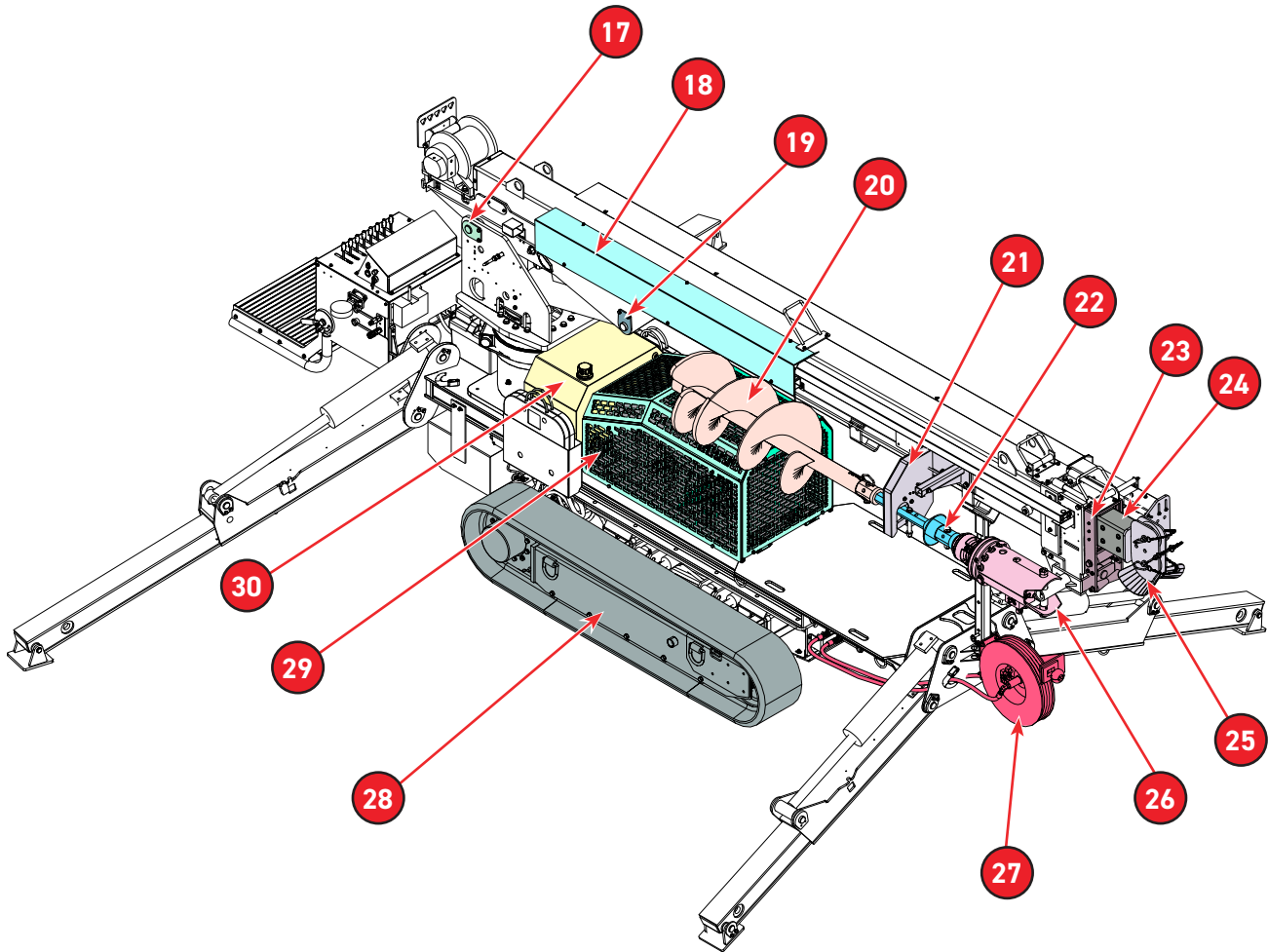

17	Boom Pivot Pin	24	Fiberglass Boom
18	Auger Cattrack Cover	25	Sheevehead
19	Lift Cylinder Boom Pin	26	Auger Drive
20	Auger	27	Hose Reel
21	Auger Stow	28	Track Undercarriage
22	Kelly Bar Extension	29	Engine Cover
23	Secondary Boom	30	Hydraulic Tank

35-48DR

Description of Machine
Machine Component Identification

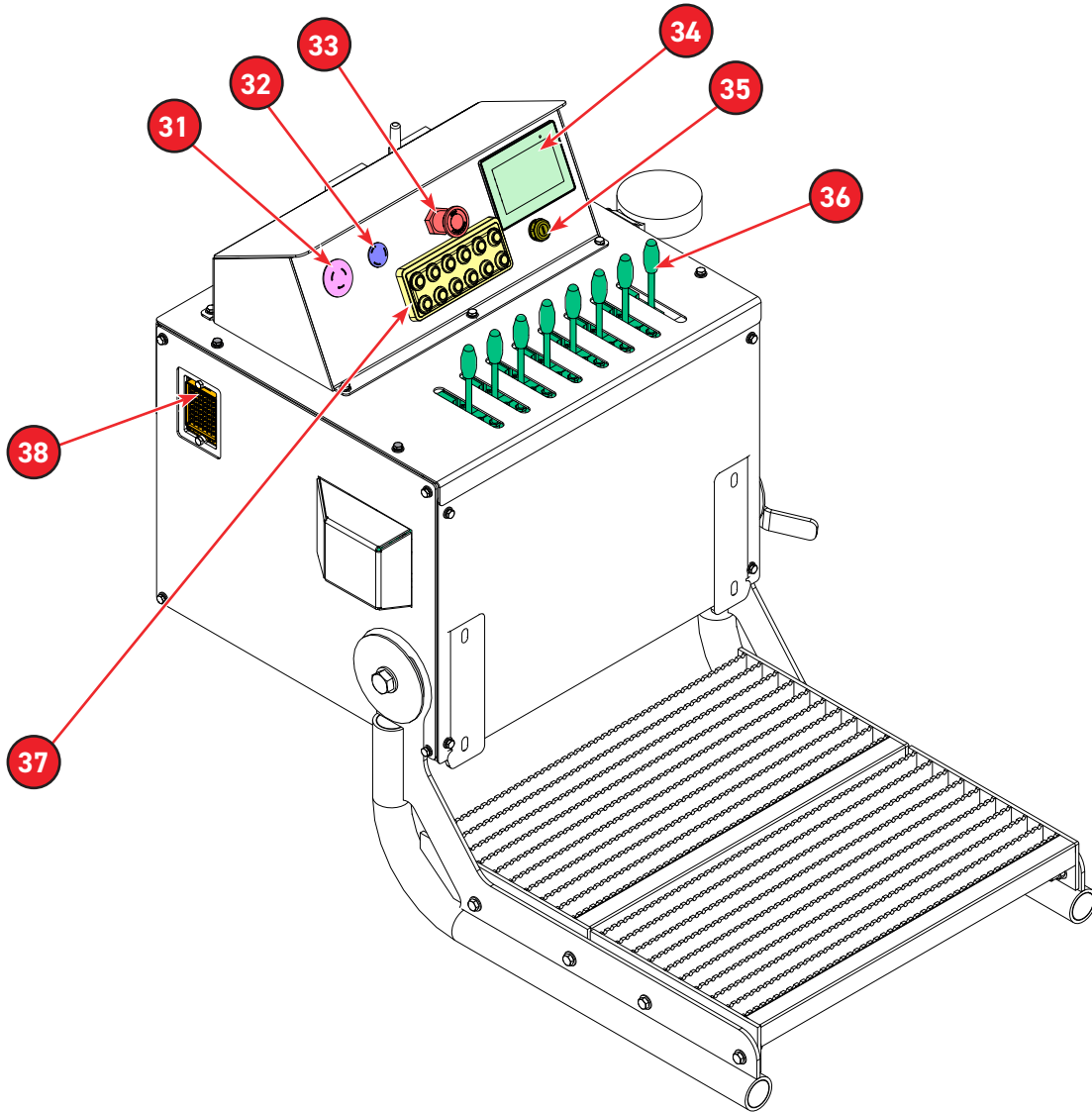

31	Tilt Alarm
32	Outrigger Override Alarm
33	Emergency Stop
34	Machine Performance Screen
35	Engine ON/OFF
36	Boom, Outriggers and Track lever controls
37	Machine Controls Keypad
38	Fuse

35-48DR

Description of Machine Grease Fitting Locations

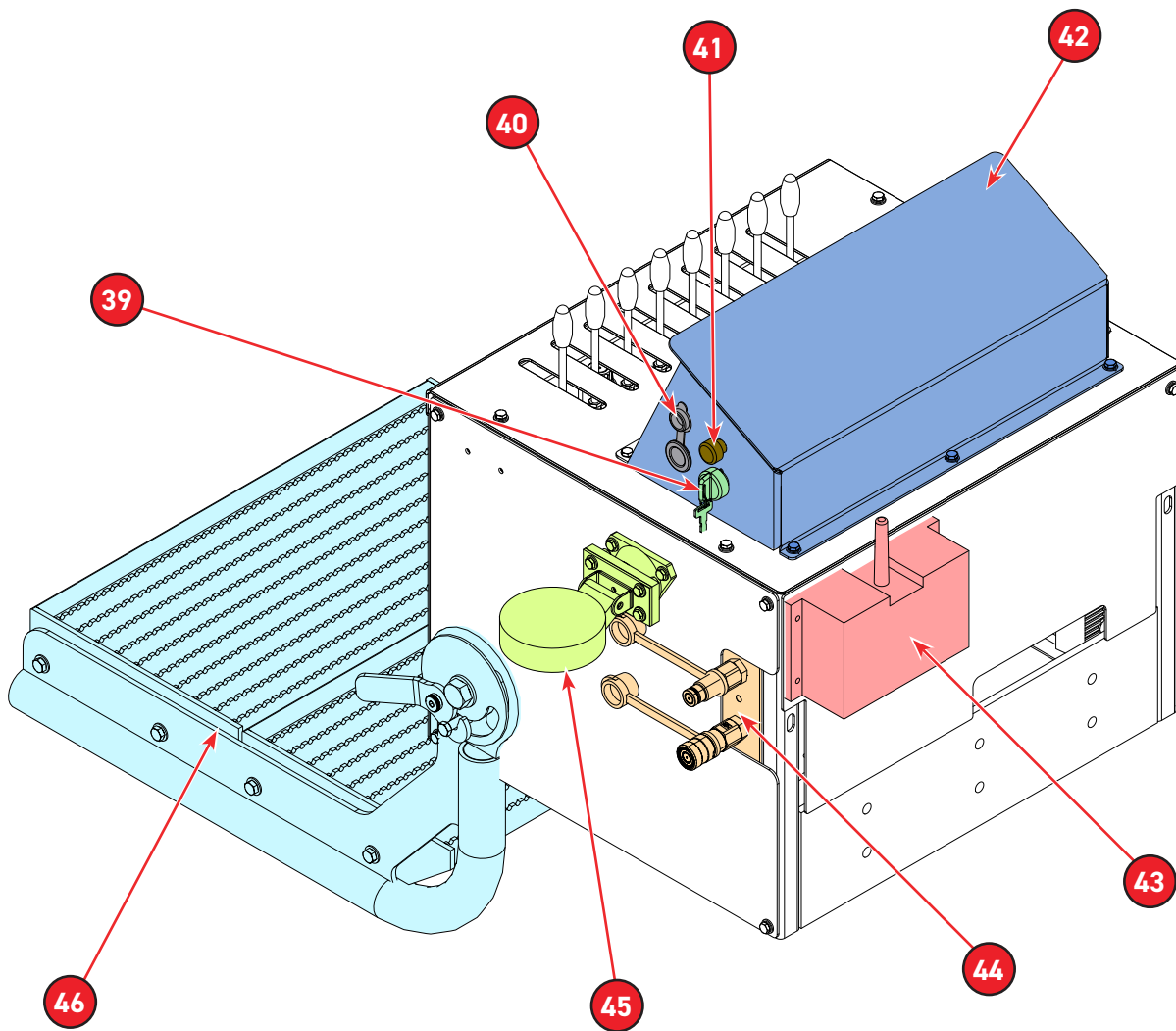

39	Outrigger Override
40	12VDC Accessory
41	HOP Override
42	Dog Housing
43	Radio Remote Receiver
44	Tool Circuit
45	Light
46	Operators Platform

35-48DR

Description of Machine
Grease Fitting Locations

Grease Fitting Locations

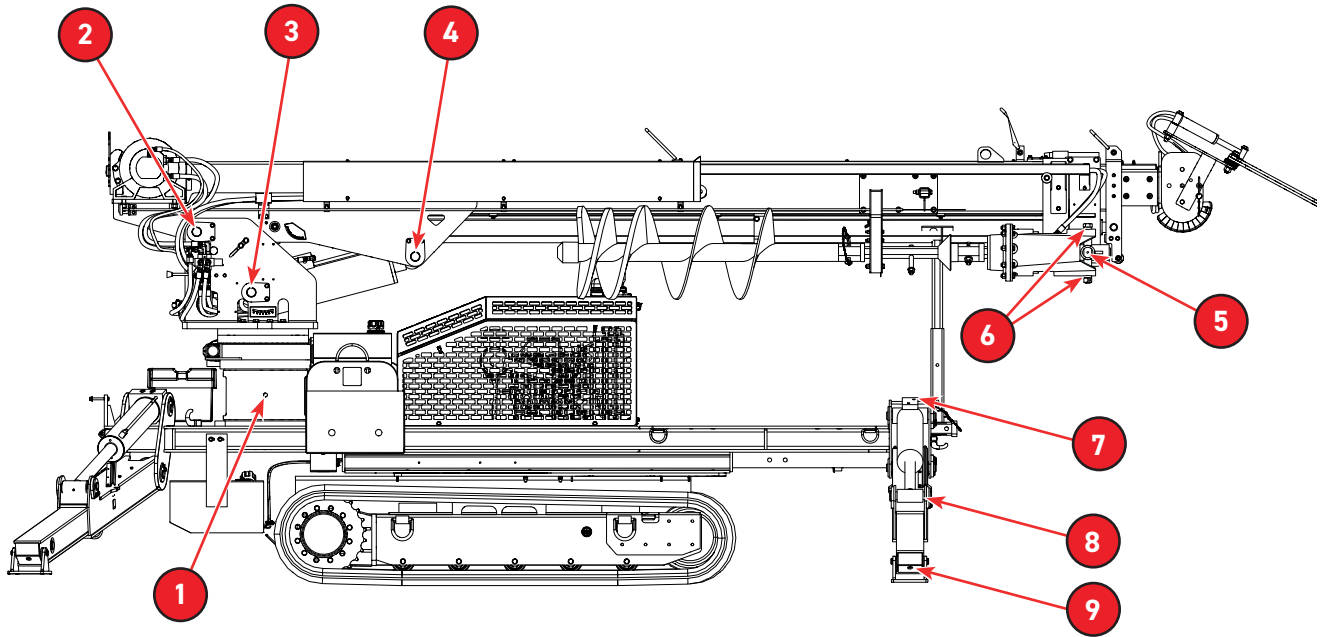

1	Rotation Gear	6	Auger Swing Pivot
2	AMain Boom Rear Pivot	7	Jack Cylinder Barrel pin
3	Main Lift Cylinder Lower	8	Jack Cylinder Rod Pin
4	Main Lift Cylinder Upper	9	Outrigger Foot Pin
5	Auger Swing Pivot		

35-48DR

Description of Machine
Auger Drive Assembly

Auger Drive Assembly

Planetary Gear Reducer

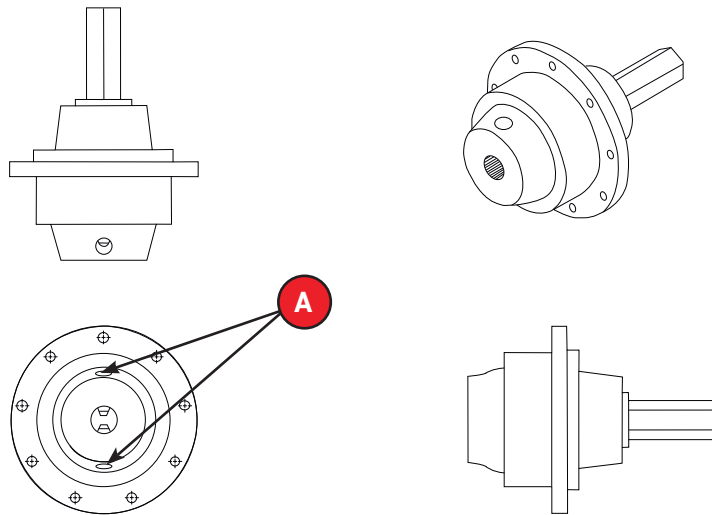
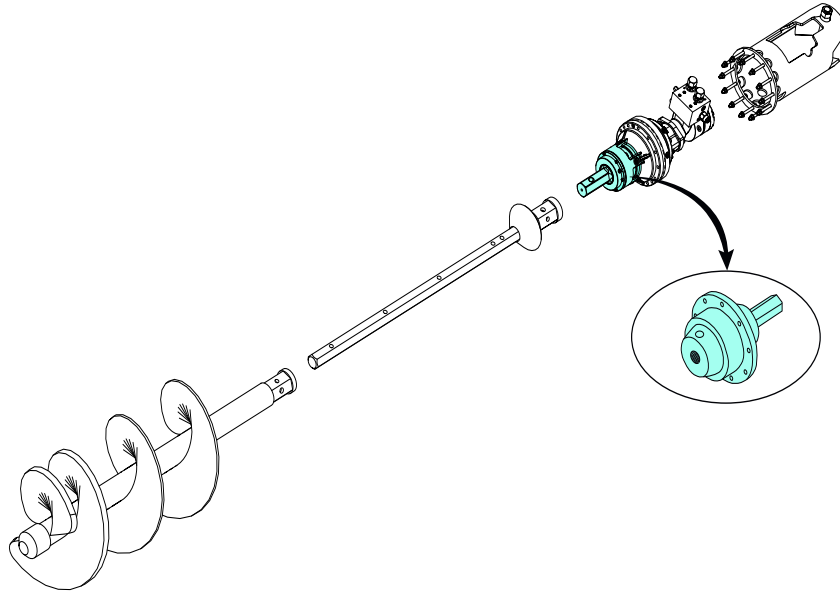

A Oil Fill / Drain Plugs

Gear Lube Requirement	
SAE Viscosity Grade	Recommended Minimum Temperature
75W-90	-40°F
80W, 80W-90	-15°F
85W, 85W-90	10°F
90	35°F
31oz. Oil Capacity	

35-48DR

Description of Machine

Outback 35-48DR Engine Information



Outback 35-48DR Engine Information

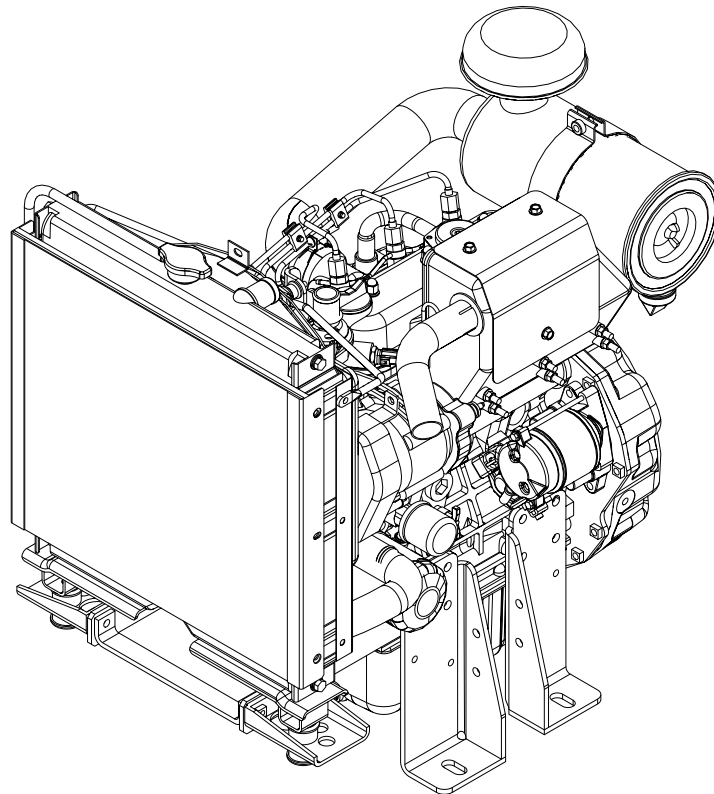

Engine Type	Kubota D1105 Diesel
Engine Oil	
Quantity	1.3 U.S. Gal.
Type	10W-30 (CI-4 or better)
Interval	50 Hours Initial & 200 hours Regularly
Oil Filter #	C1084346
Air Cleaner	
Air Filter #	C1084347
Rain Cap #	C1084348
Interval	Clean Every 100 Hours, Change Yearly
Fuel Filter	
Fuel Filter (Clear) #	C1084349
Fuel Filter (Metal) #	C1084350
Interval	Check Clear Unit Every 100 Hours, Change Both Every 400 Hours.

Engine Model	Item	Oil Pan Depth	Initial	Interval
D1005-E4	Engine Oil	125 mm (4.9 in.) or above	50 Hours	200 Hours
	Oil Filter Cartridge	Below 101 mm (4.0 in.)		

35-48DR

Description of Machine

Single Bucket Arm Adapter

Single Bucket Arm Adapter

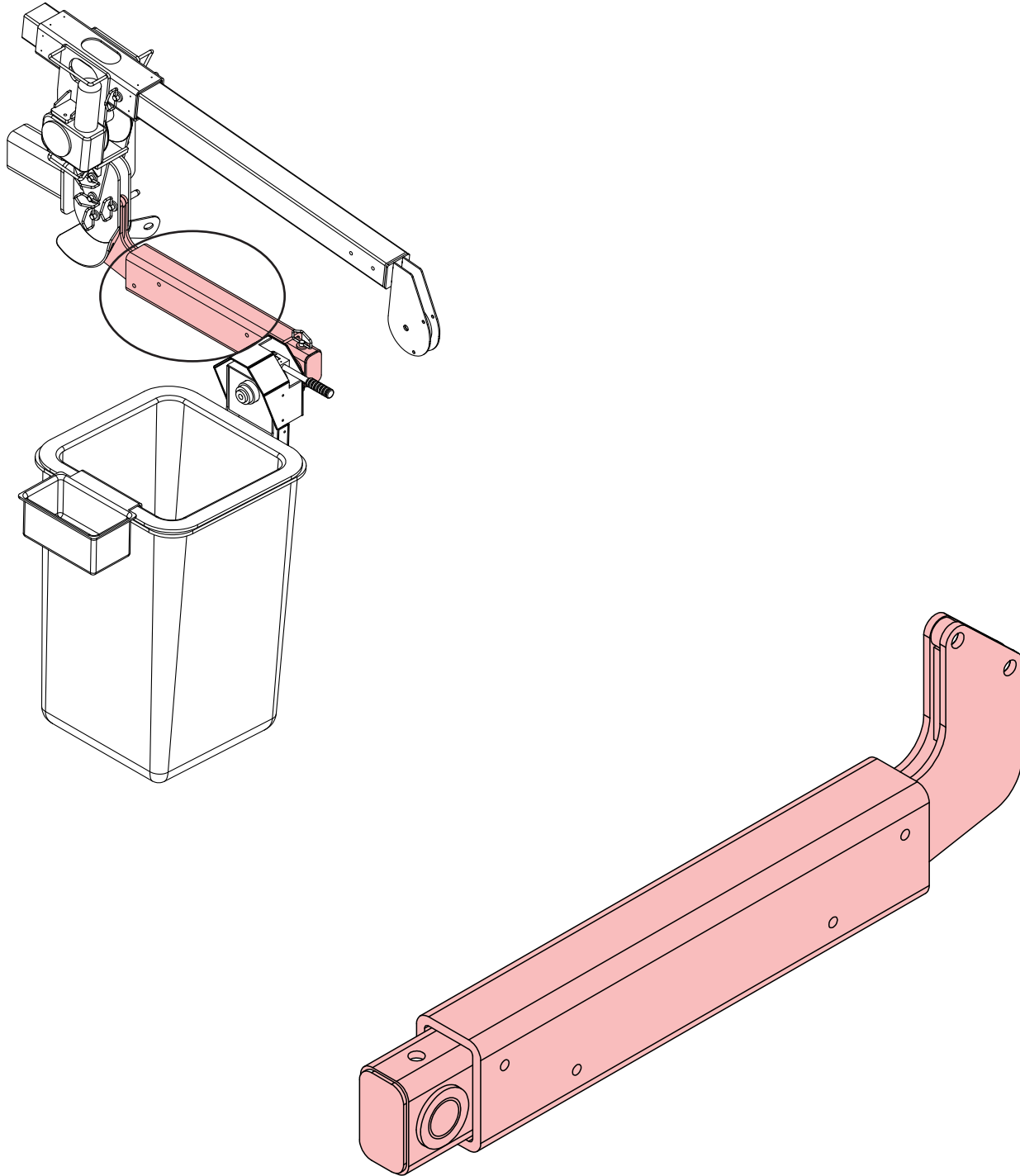

Dual Bucket Adapter

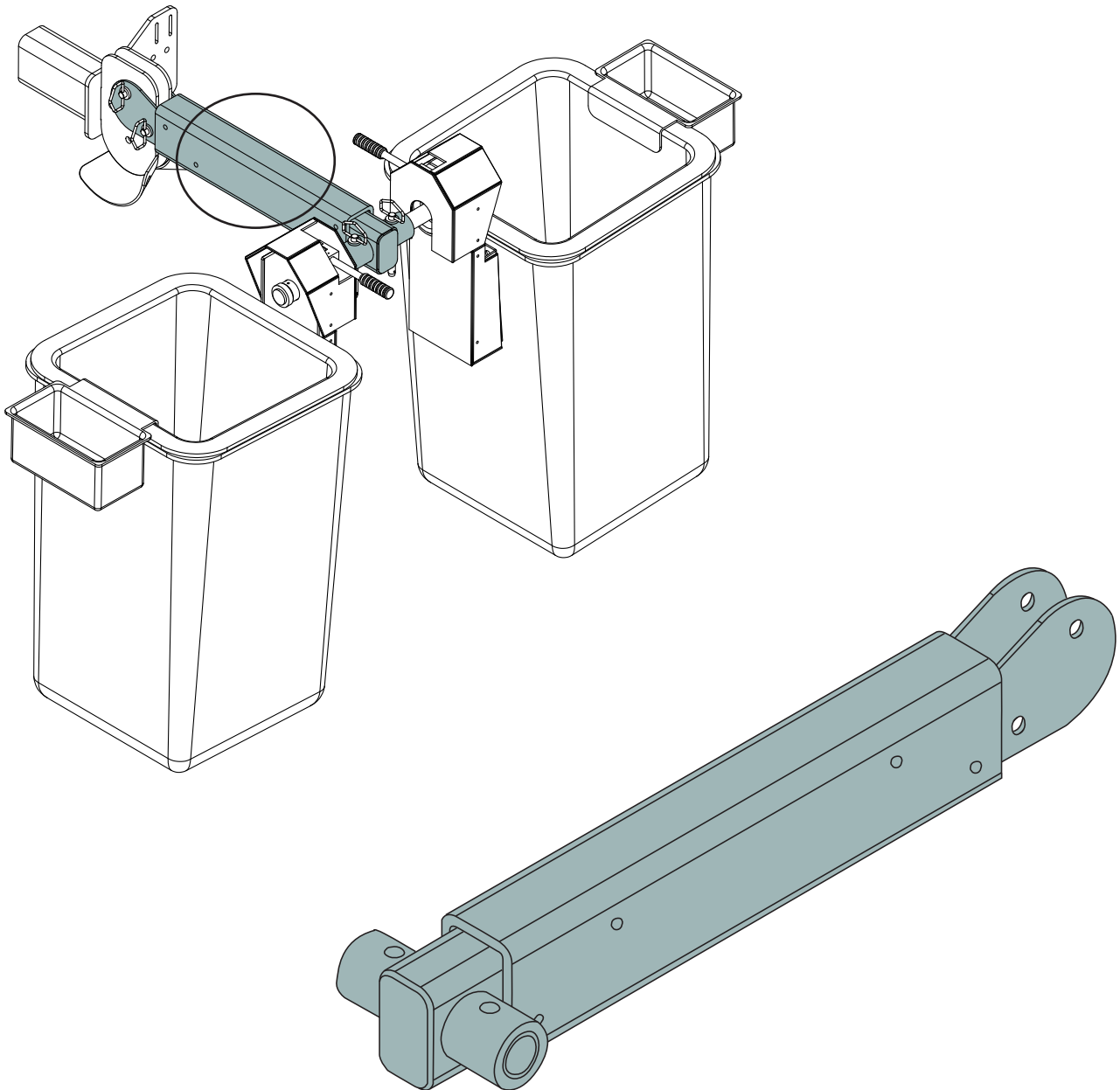

35-48DR

Description of Machine
Dual Bucket Pin Location

Dual Bucket Pin Location

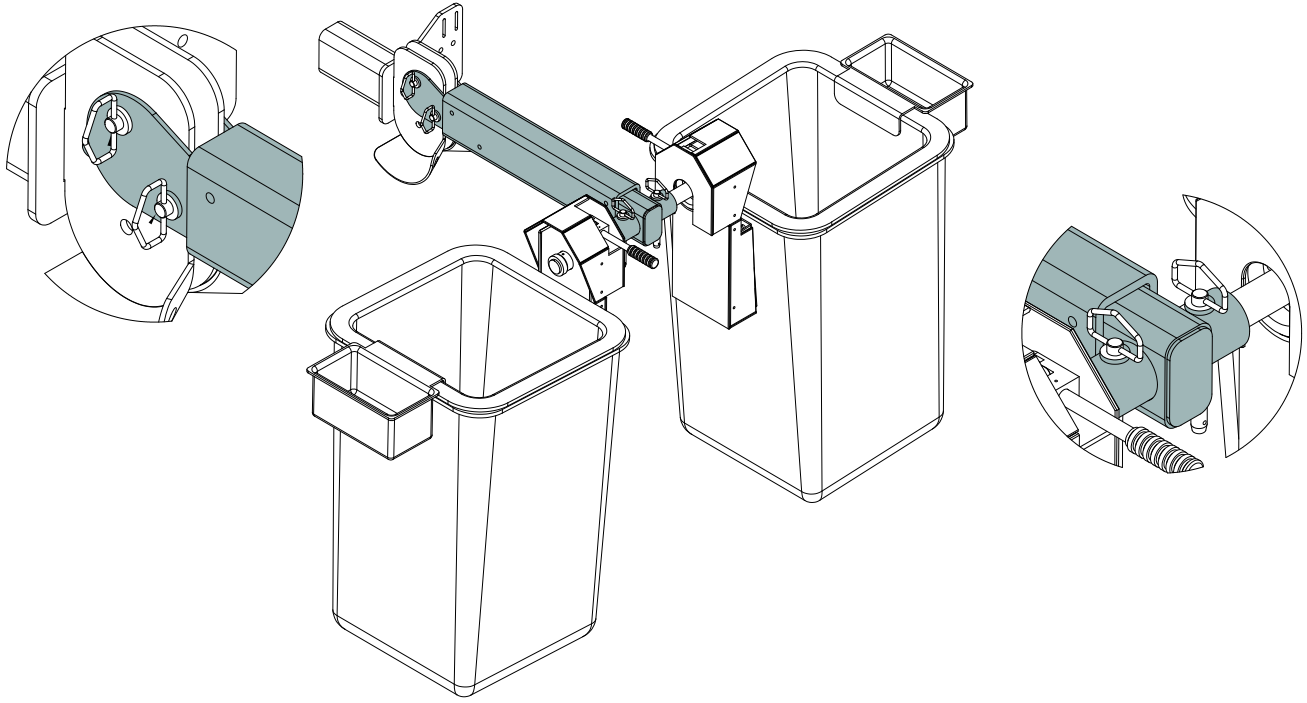

Pole Claw

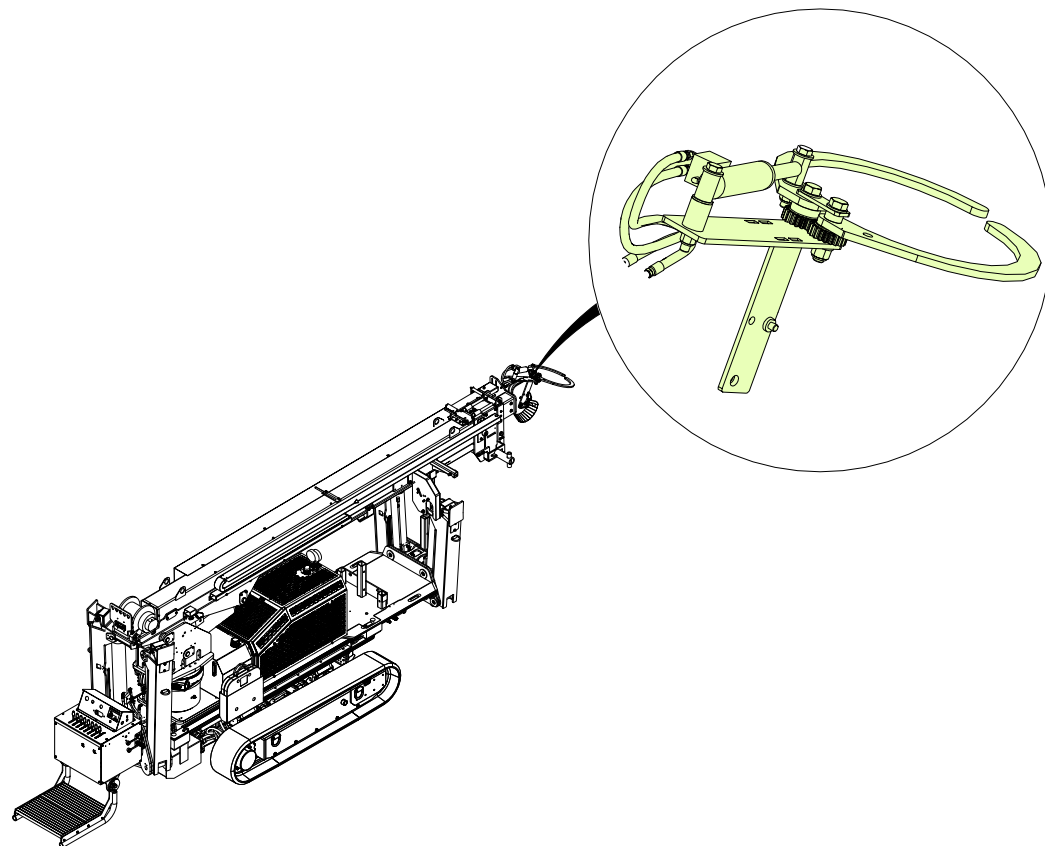

Can Handler

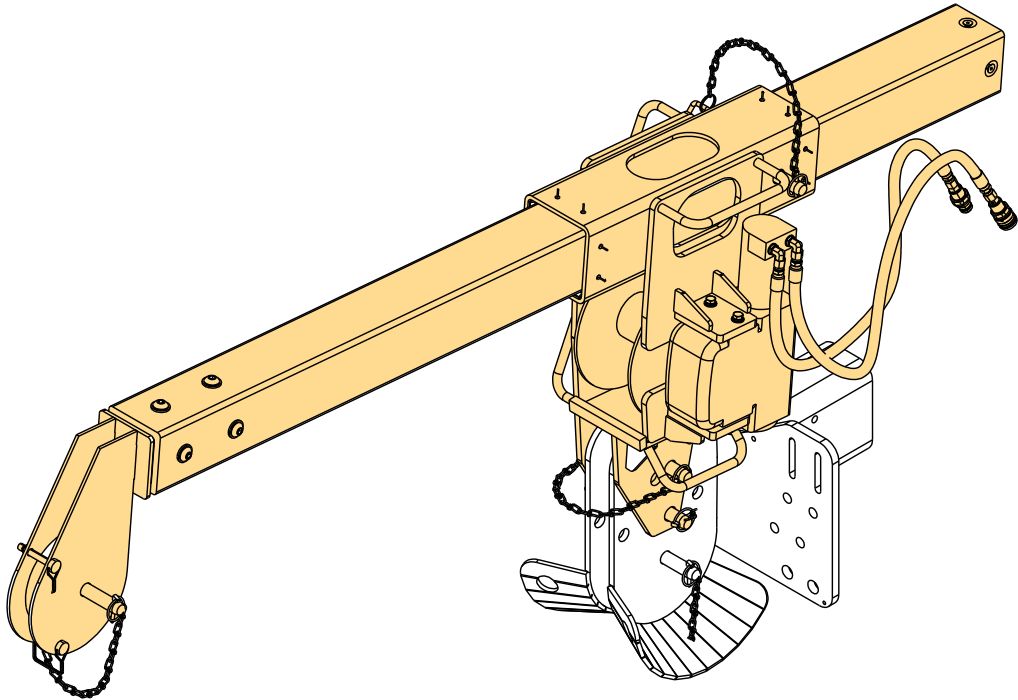

Material Handler

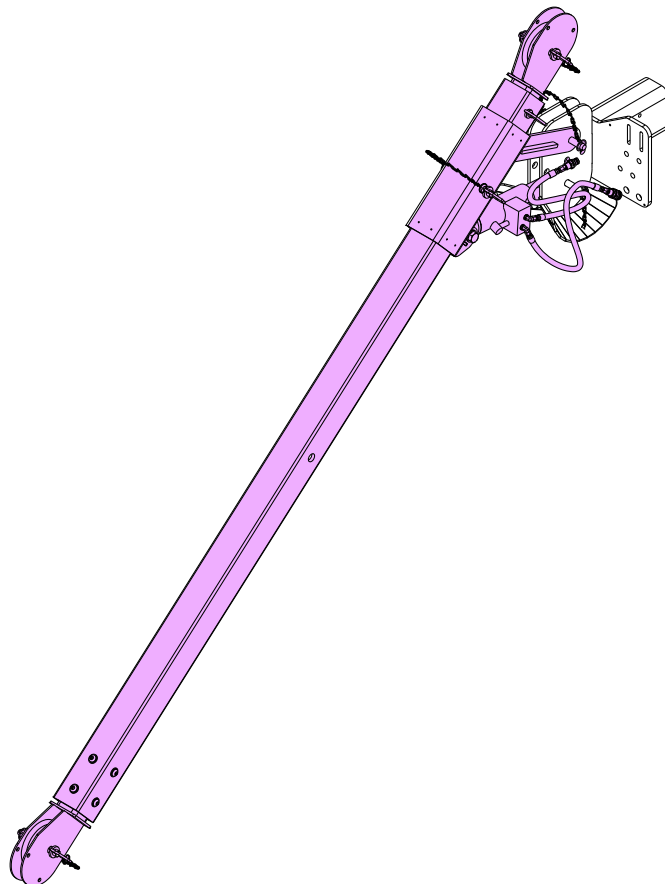

PAGE INTENTIONALLY LEFT BLANK

Operating Instructions

Starting Instructions

Before starting the **Load King** Outback 35-48DR, it is necessary to perform all the periodic inspections and lubrications. Perform the following steps to start the machine properly.

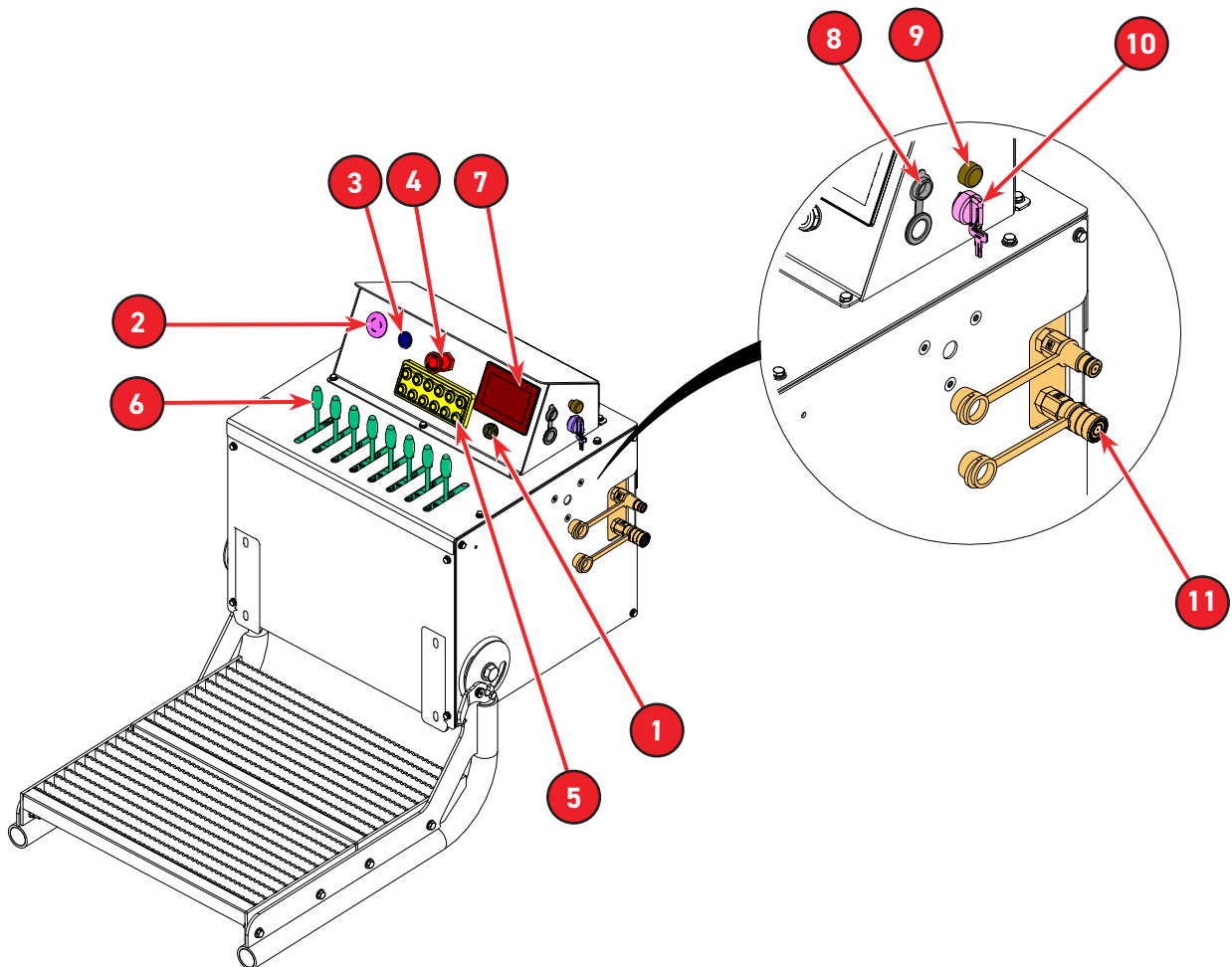

1	Engine ON/OFF	7	Display 5" IQAN MD5-5
2	Tilt Alarm	8	12VDC Accessory
3	Outrigger Override Alarm	9	HOP Override
4	Emergency-Stop Switch	10	Outrigger Override
5	Keypad/Remote	11	Tool Circuit
6	Boom, Outriggers and Track Lever Controls		

35-48DR

Operating Instructions
Starting Instructions

1. Engine ON/OFF

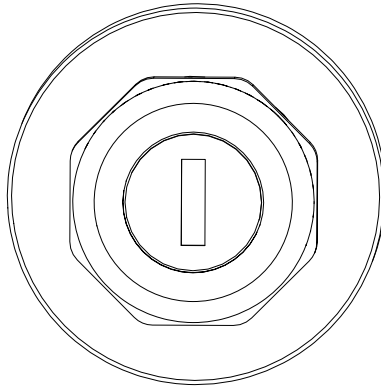

2. Tilt Alarm

Load King advises operator's to always remain alert when operating the **Load King** Outback 35-48DR. Be aware of all obstacles in your surroundings at all times. The **Load King** Outback 35-48DR is equipped with bubble level angle indicators and an audible slope alarm. This alarm can be found on the operator panel. The slope gauge measures both fore-and-aft and side-to-side slope. If the **Load King** Outback 35-48DR approaches the machine's maximum slope limit for safe operation, a warning light will begin to flash on the operator panel. When the machine reaches the maximum slope limit, an audible alarm will sound, and the warning light will continue to flash. If the slope alarm is activated, stop all activity immediately and assess what is needed to bring the machine back into safe operating condition. Proceed with caution to ensure you can safely relocate the machine.

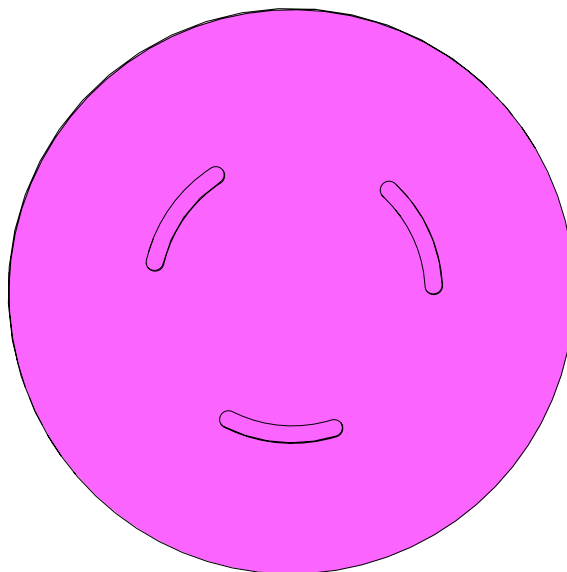

35-48DR

Operating Instructions
Starting Instructions

3. Outrigger Override Alarm

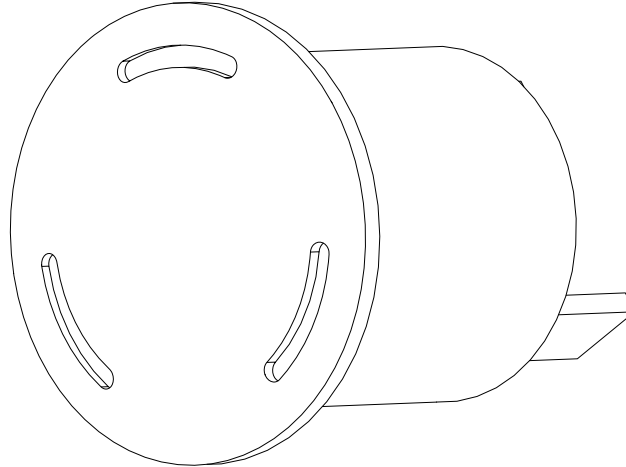

4. Emergency-Stop Switch

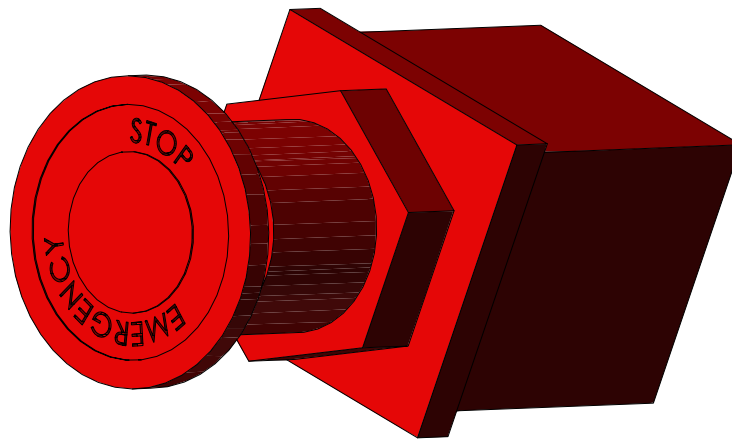

Emergency-Stop Switch: Stops (Disengages) crane electronics, hydraulic and engine, When there is a risk of injury to personnel, or damage to property or equipment.

35-48DR

Operating Instructions Starting Instructions

5. Keypad

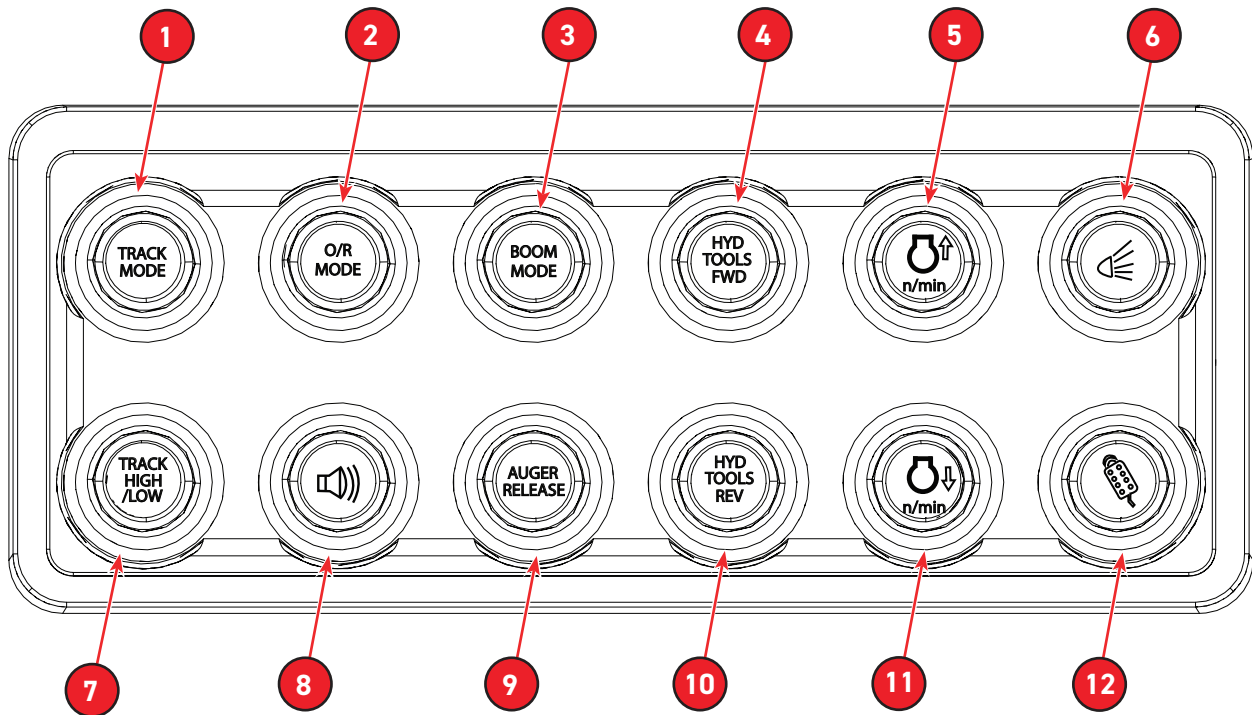

1	Track Mode	7	Track High/Low Speed
2	Outrigger Mode	8	Horn
3	Boom Mode	9	Auger Release
4	Hydraulic Tools Forward	10	Hydraulic Tools Reverse
5	Engine High Speed	11	Engine Low Speed
6	Lights	12	Remote

6. Machine Control Levers

	To operate any of the machine's hydraulic control levers for boom, outriggers, and tracks, first access the control keypad indicated in the diagram below.
---	--

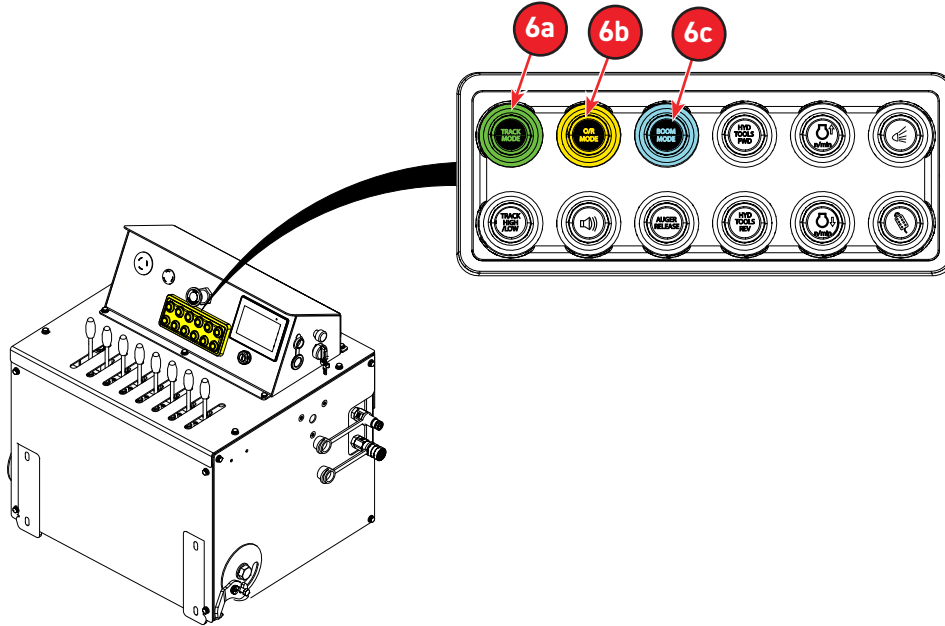



6a	Track mode Push button to operate track control levers.
6b	Outrigger mode push button to operate outriggers control levers.
6c	Boom mode push button to operate boom control levers.

6a. Undercarriage Track Extension/Retraction

The undercarriage of the **Load King** Outback 35-48DR has the ability to hydraulically extend and retract the tracks. This ability will make the track undercarriage wider or narrower as necessary to allow passage through narrow spaces.

	Undercarriage tracks should ALWAYS stay in the most extended configuration unless traveling through a narrow gate.
---	--

	ALWAYS have the tracks extended when loading and unloading the machine from its trailer.
---	--

	Do not travel with machine's tracks retracted when there is sufficient room to have them extended.
---	--

35-48DR

Operating Instructions Starting Instructions

There are two proximity sensors on the track undercarriage that monitor the tracks orientation. Perform the following steps to extend or retract the track undercarriage.

1. Ensure that the **Load King** Outback 35-48DR is on a level, safe work area.
2. Start the **Load King** Outback 35-48DR and let the machine idle for a few minutes.
3. Press the "TRACK MODE" push button on the machine's control keypad. When the push button is pressed, a green light illuminates the push button. Then, hydraulic control levers are utilized to operate the tracks. See the illustration for reference.

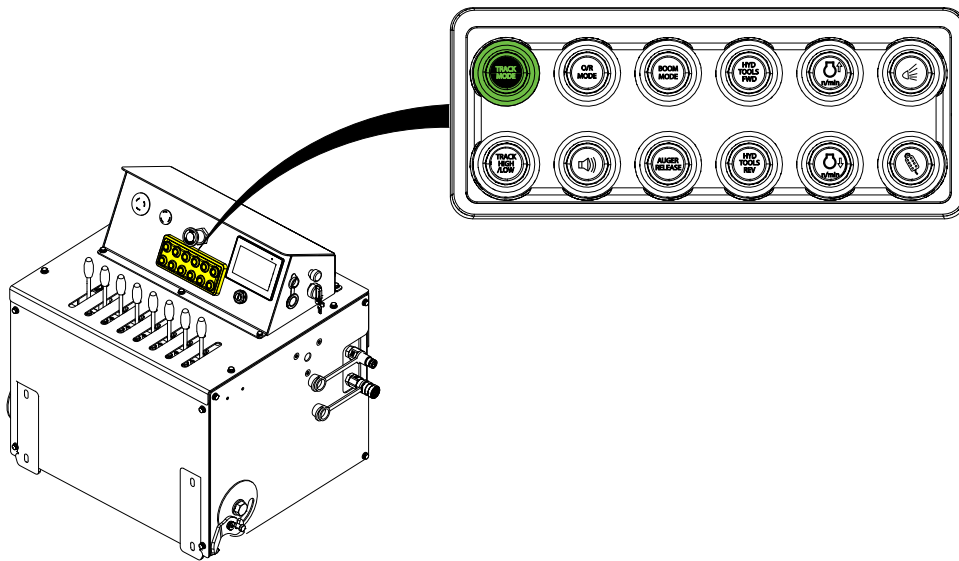

4. **Load King** Outback 35-48DR are able to extend or retract the undercarriage. To extend and retract the undercarriage, move the undercarriage's hydraulic valve handle as shown in the illustration. The terrain that the machine is riding on will determine how easily the tracks will move. Certain terrains make it more difficult to extend/retract the undercarriage. If machine is not able to retract/extend the undercarriage, deploy the outriggers and raise the machine off the ground. Then extend/retract the undercarriage.

35-48DR

Operating Instructions
Starting Instructions

Control Lever Specifications

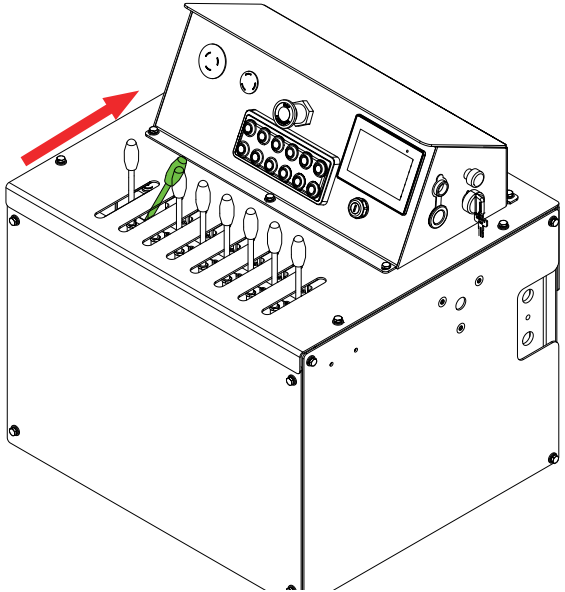
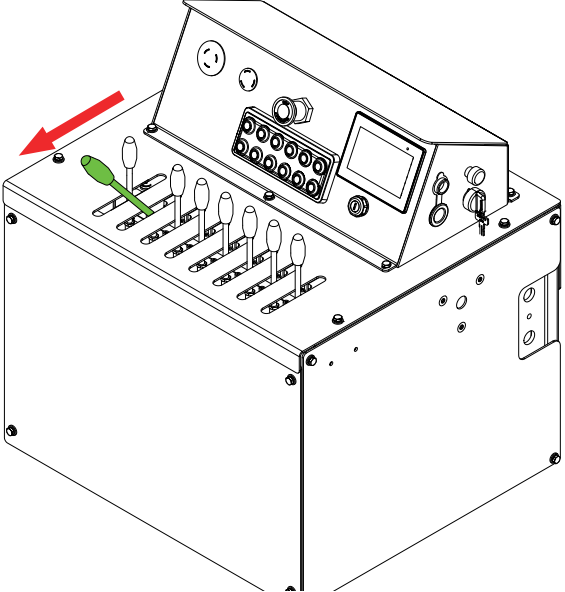
<p>Machine Undercarriage Extend</p> <p>Push the hydraulic lever forward to extend.</p>	
<p>Machine Undercarriage Retract</p> <p>Pull the hydraulic lever backward to retract.</p>	

35-48DR

Operating Instructions
Starting Instructions

Machine Travel

This steering configuration is very similar to standard skid steer or zero-turn lawn mowers. The engine must be running and the "TRACK MODE" push button on keypad must be "ON". [See picture](#) for reference to where the hydraulic levers are for the drive controls.

To Go Forward

Push both hydraulic levers forward simultaneously

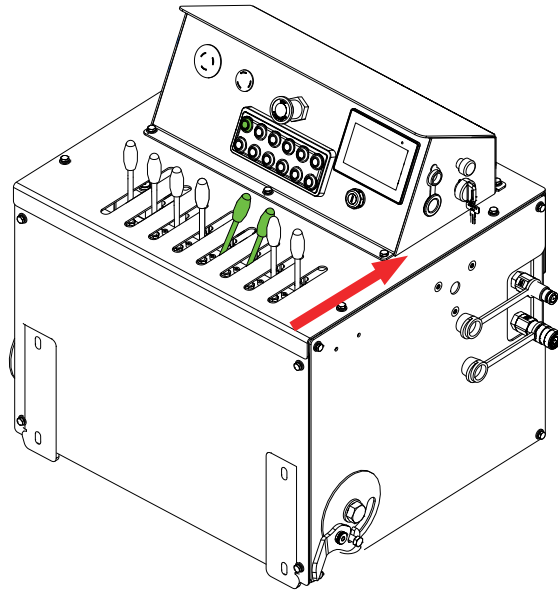

To Go In Reverse

Pull both hydraulic levers back simultaneously.

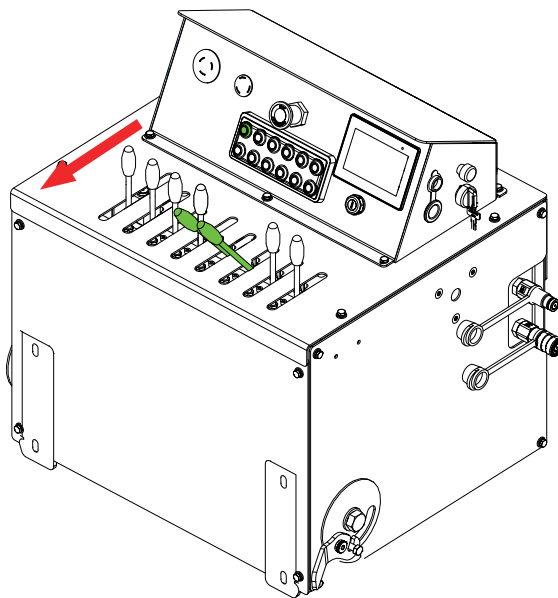

35-48DR

Operating Instructions
Starting Instructions



Turning

The **Load King** Outback 35-48DR has a traditional “skid steer” type of steering where the left track is controlled by one hydraulic handle and the right track is controlled by another hydraulic handle.

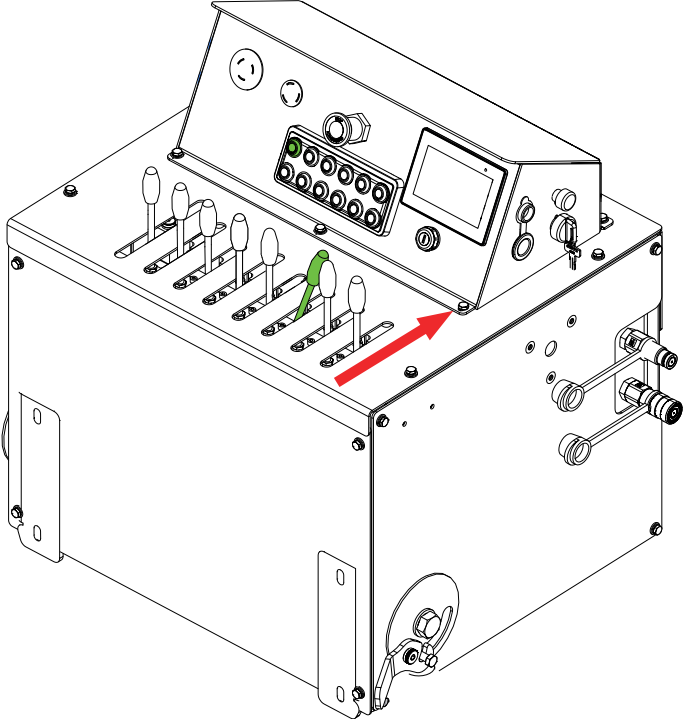
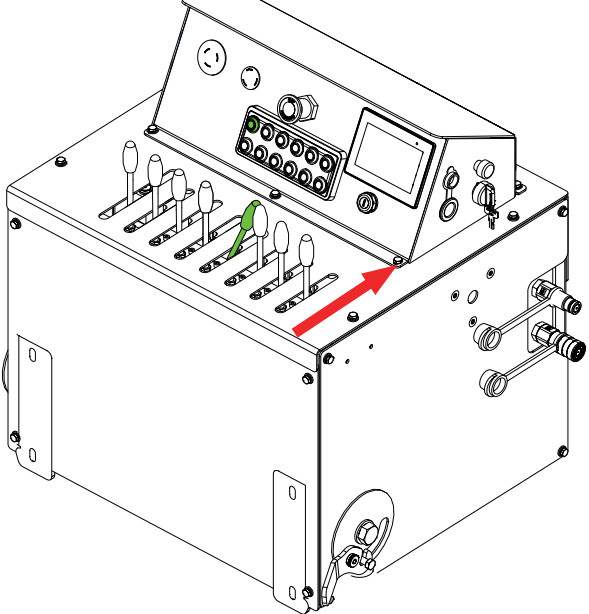
<p>To Steer The Machine Left</p> <p>The right hydraulic handle must be pushed forward.</p>	
<p>To Steer The Machine Right</p> <p>The left hydraulic handle must be pushed forward.</p>	

35-48DR

Operating Instructions Starting Instructions

6b. Deploying Outriggers

The **Load King** Outback 35-48DR comes with four (4) hydraulically-driven outriggers as standard on every machine. These outriggers are used for machine stability when operating the boom functions.



Do not operate the boom without the use of the outriggers.



Failure to use outriggers properly can result in serious injury or death.

The following instructions are how to deploy the outriggers. The instructions are assuming that the engine is running and the machine is in the working area.

1. Ensure that the work area is clear of any obstructions.

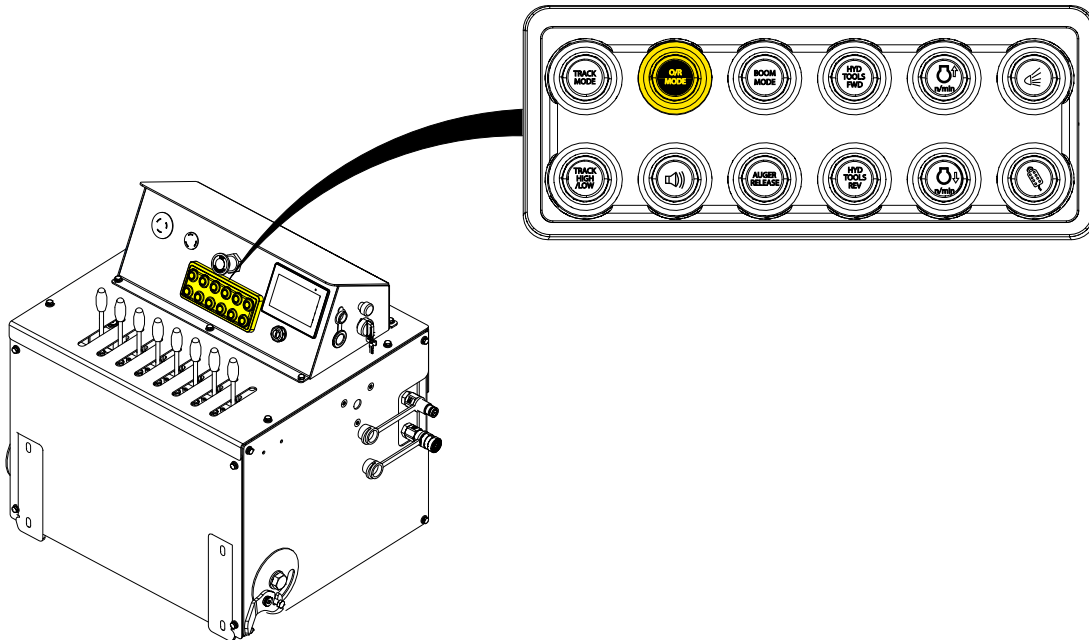

2. Press the "Outrigger MODE" push button on the machine's control keypad. When the push button is pressed, an "YELLOW LIGHT" illuminates the push button. Then, hydraulic control levers are utilized to operate the outriggers. See the illustration for reference
3. Move the hydraulic outrigger function levers to engage the outriggers down the ground.
 - Hydraulic outrigger function levers are located at the top of valve assembly. There are eight available levers. See the diagram on following page to deploy the outriggers.
 - If equipped with outrigger pads, place pads in approximate location of outrigger feet then drive outriggers down onto pads.

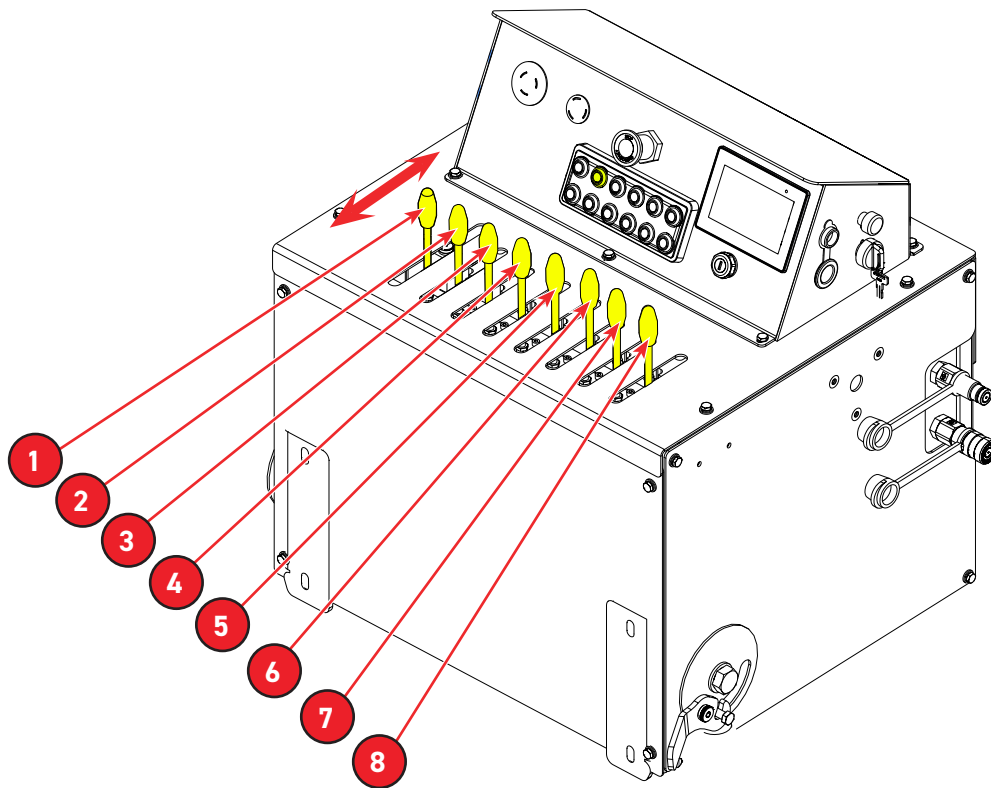

1	Left Rear Jack Down and Up	5	Right Front Beam Out and In
2	Left Rear Beam Out and In	6	Rear Front Jack Down and Up
3	Left Front Jack Down and Up	7	Right Rear Beam Out and In
4	Left Front Beam Out and In	8	Right Rear Jack Down and Up



Ensure that the right front outrigger beam is fully retracted; otherwise, contact with the auger may cause damage.



Always keep other personnel clear of machine when deploying outriggers.

4. Drive outriggers into ground until machine is stable and level.
 - **Load King** recommends that the track undercarriage as low to the ground as possible while still putting the machine in a stable state, to increase stability.
 - Use the slope gauge to level out the machine. **Load King** recommends to use the machine on the most level position possible.

35-48DR

Operating Instructions Starting Instructions



There is an tilt alarm which warns. when the machine is not leveled and stable at ground. Failure of proper leveling on ground can result in serious injury or death.

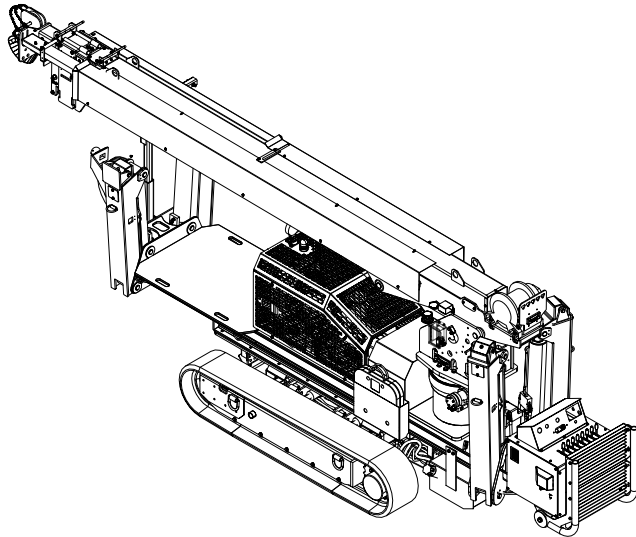

Outrigger Stowed Position

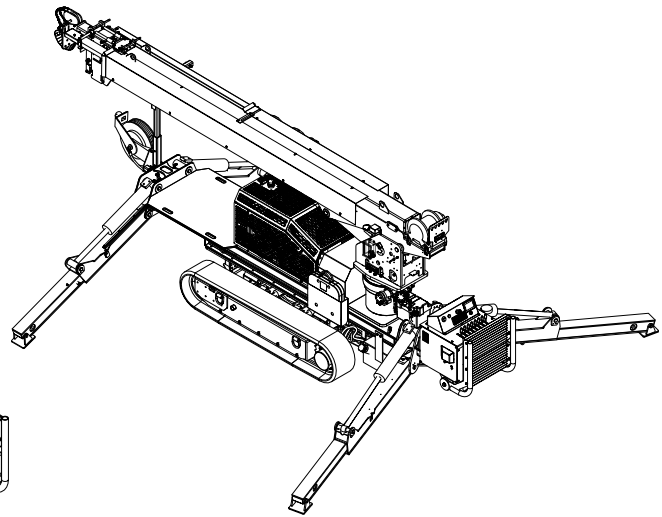

Outrigger Deployed Position

6c. Boom Operation/Controls

The **Load King** Outback 35-48DR is equipped with a telescopic boom. **Load King** recommends any Operator receives training on how to operate the Outback 35-48DR prior to operation.



Improper operation can lead to serious injury or death.

The **Load King** Outback 35-48DR comes standard with hydraulic boom controls. The following instructions are how to get the machine into "BOOM CONTROL" mode. Once in "BOOM CONTROL" mode, are able to exercise the boom function levers. Please reference the boom manufacturer's operation manual for further instruction on how to operate the boom assembly.

The following instructions assume the machine's engine is running.

1. Ensure that work area is clear of any obstructions.
2. Deploy the outriggers and ensure machine is stable and level.
 - Outriggers must be used for any type of boom function.
3. Deploy the Operator platform of the **Load King** Outback 35-48DR machine. [See diagram](#) on following page for reference.

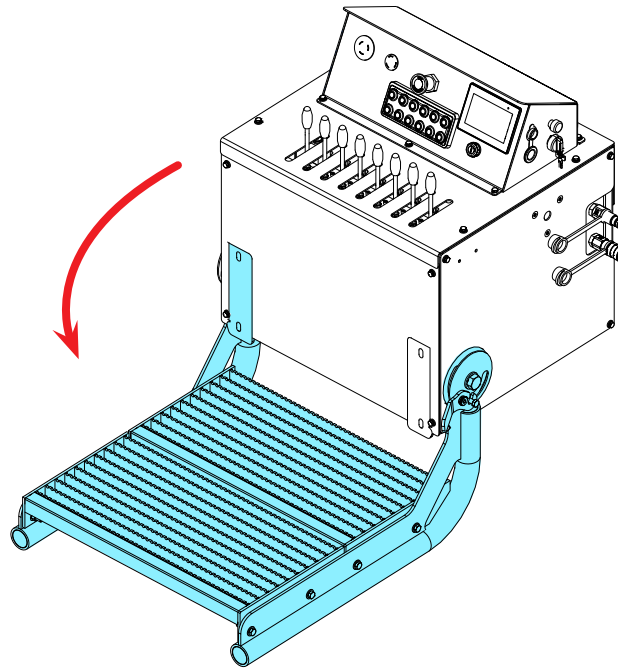

Operator Platform Deployment

4. To operate the boom press the "BOOM MODE" push button on the machine's control keypad. When the button is pressed, a "BLUE LIGHT" illuminates the push button. Then, hydraulic control levers are utilized to operate the tracks. See the illustration for reference



Before pressing the boom push button, ensure that the outriggers are deployed. If the outriggers are not deployed, the boom function will not be activated.

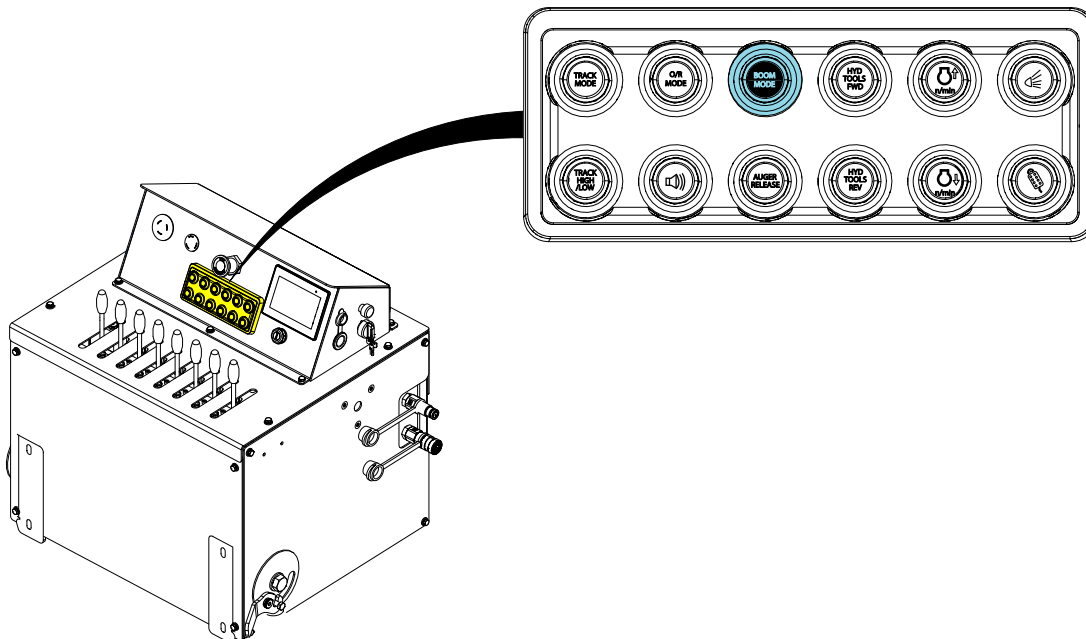

35-48DR

Operating Instructions Starting Instructions

To operate Jib/pole guide

- Push hydraulic handle forward to down and close of jib guide.
- Pull hydraulic handle back to up and open of jib guide

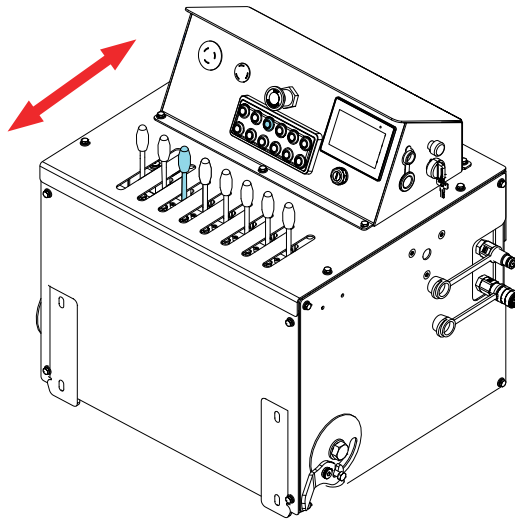

To operate Auger/winch

- Push hydraulic handle forward to down the auger.
- Pull hydraulic handle back to up the auger.

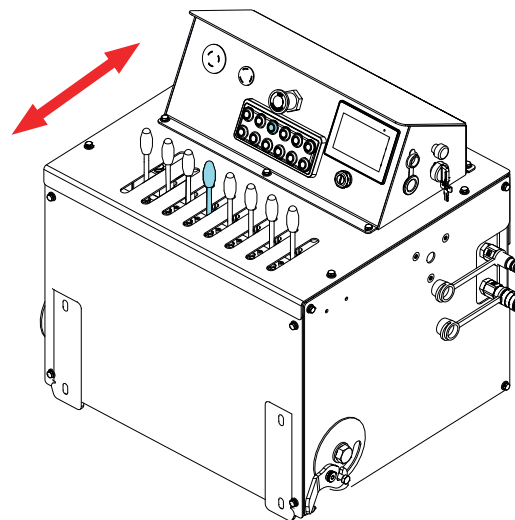

To operate Boom CW & CCW

- Push hydraulic handle forward to rotate boom in clockwise direction.
- Pull hydraulic handle back to rotate boom in counter clockwise direction.

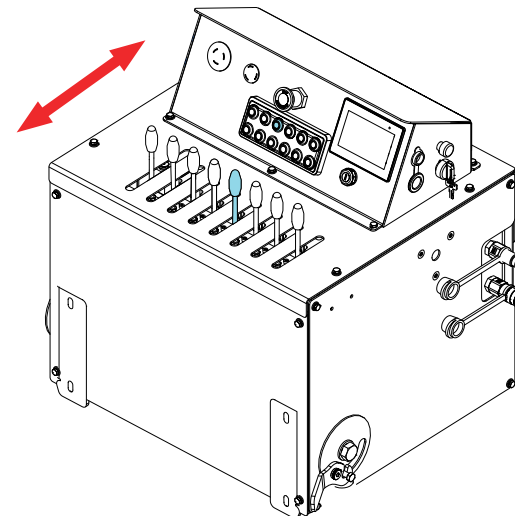

35-48DR

Operating Instructions
Starting Instructions

To operate Boom 2

- Push hydraulic handle forward to extend the second stage of boom.
- Pull hydraulic handle back to retract the second stage of boom.

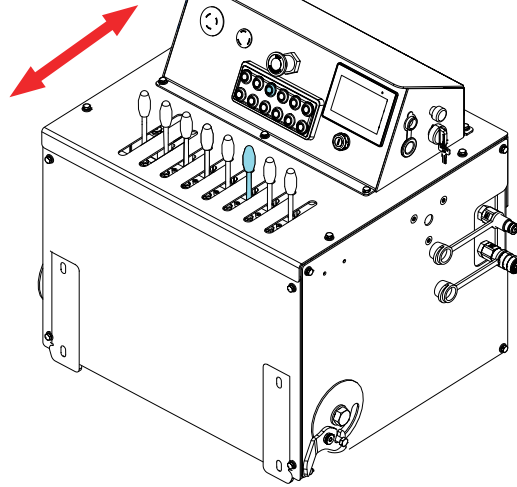

To operate Boom 3

- Push hydraulic handle forward to extend third stage of boom .
- Pull hydraulic handle back to retract third stage of boom.

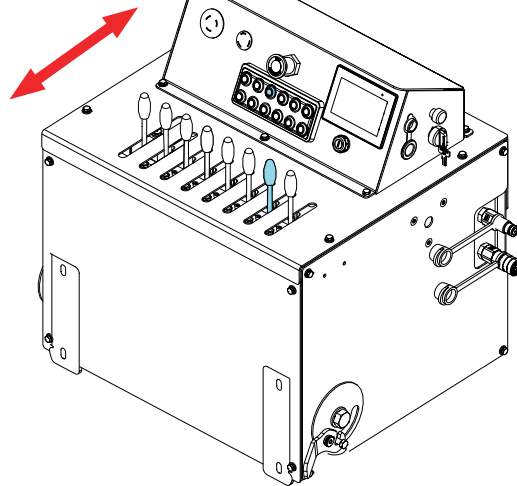

To operate Boom

- Push hydraulic handle forward to lower the boom.
- Pull hydraulic handle back to raise the boom.

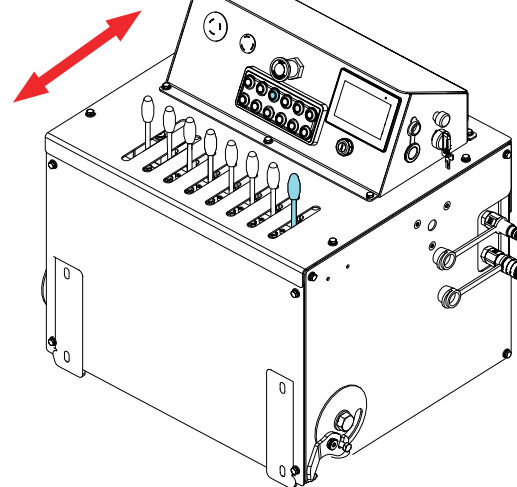

35-48DR

Operating Instructions
Starting Instructions

Throttle Control

The **Load King** Outback 35-48DR has an adjustable throttle control, used to adjust the engine RPMs. Some operations/tasks are easier with a lower engine RPM while others are easier with a higher engine RPM. This is all based on the Operator's skill level.

To increase engine RPM, there is a push button with RPM increase symbol on machine control keypad, turn it on. To decrease engine RPM, there is a push button with RPM decrease symbol on machine control keypad, turn it on. Machine idle is with no engine RPM push button on. See picture below for reference where the push buttons are located.

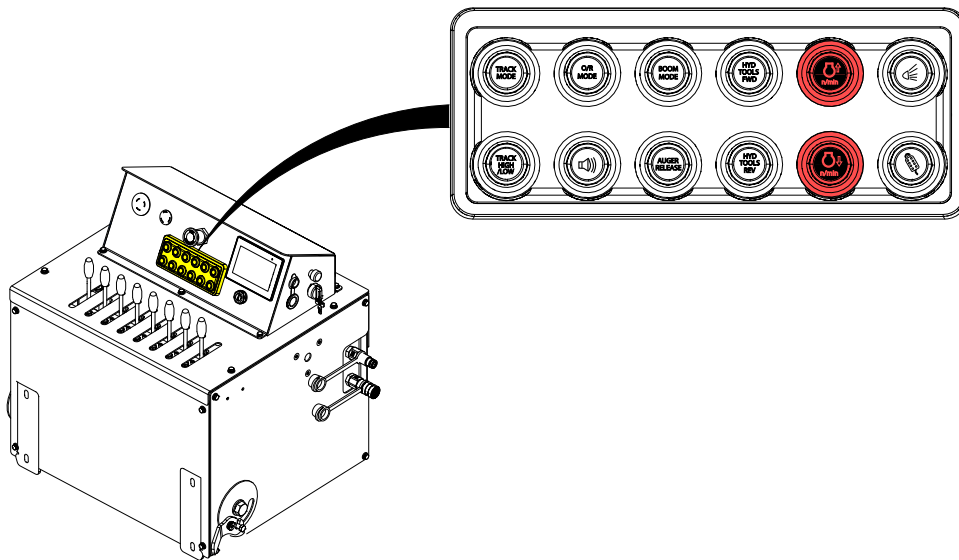

The Load King 35-48DR features an Auto Ramp Up/Ramp Down function to prevent engine stalling during slow operations. The auto ramp down also reduces excessive noise in the work environment.

35-48DR

Operating Instructions
Starting Instructions



7. Display 5" IQAN MD5-5

Track Mode



Outrigger Mode Display



35-48DR

Operating Instructions

Starting Instructions

Engine Display

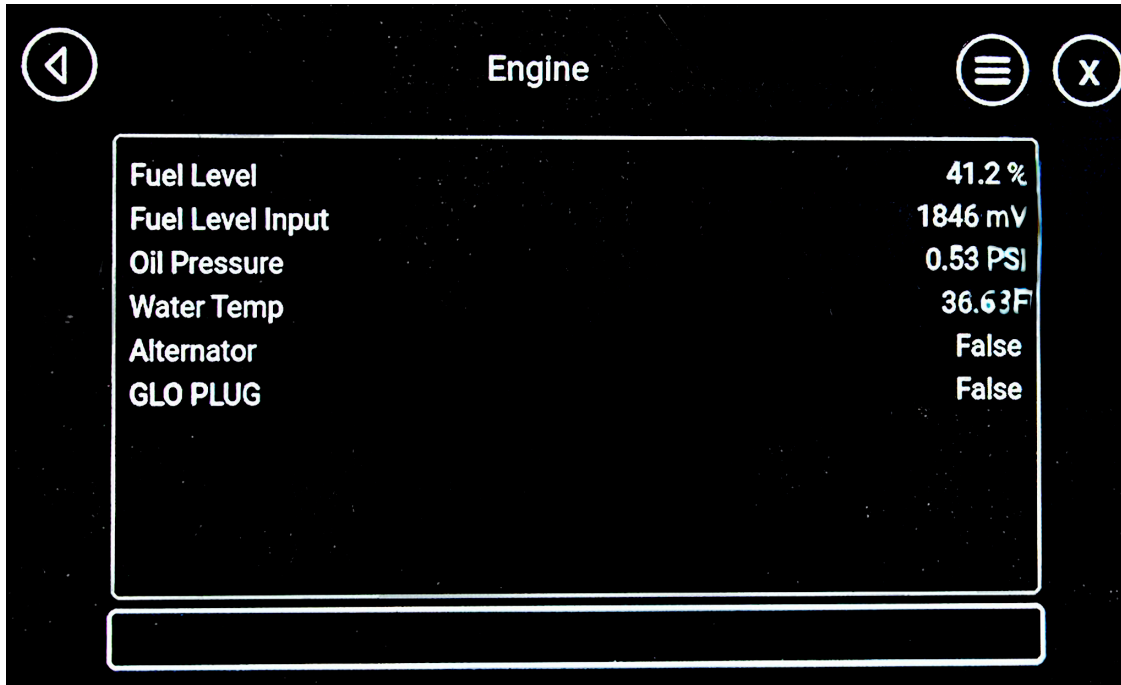

Inputs Display

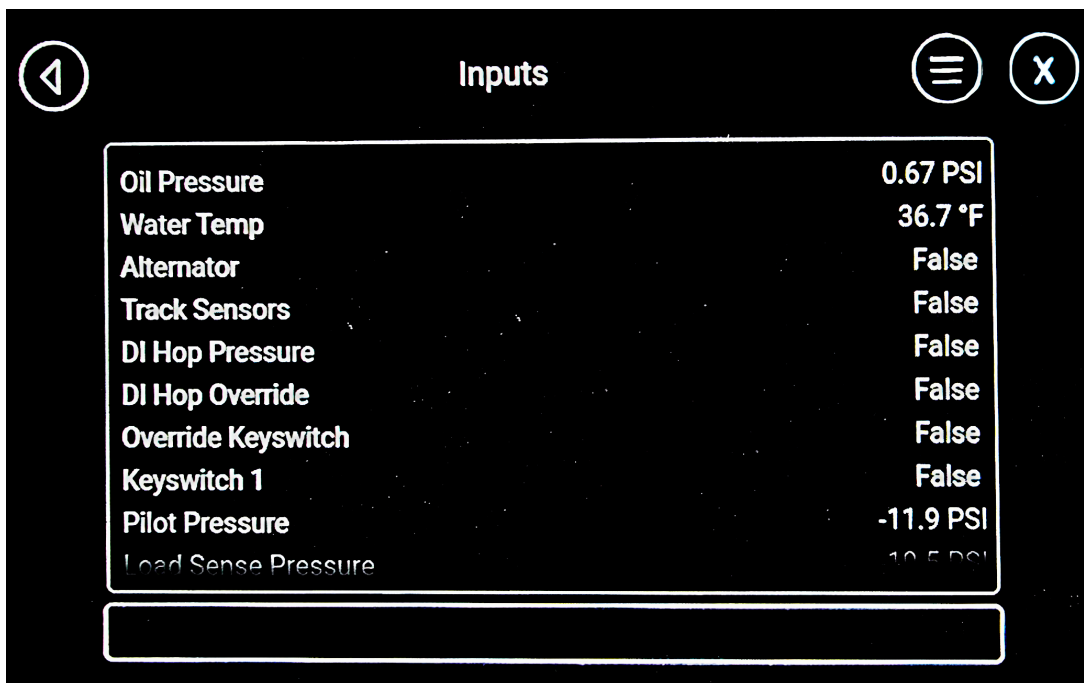

35-48DR

Operating Instructions
Starting Instructions

Outriggers Display

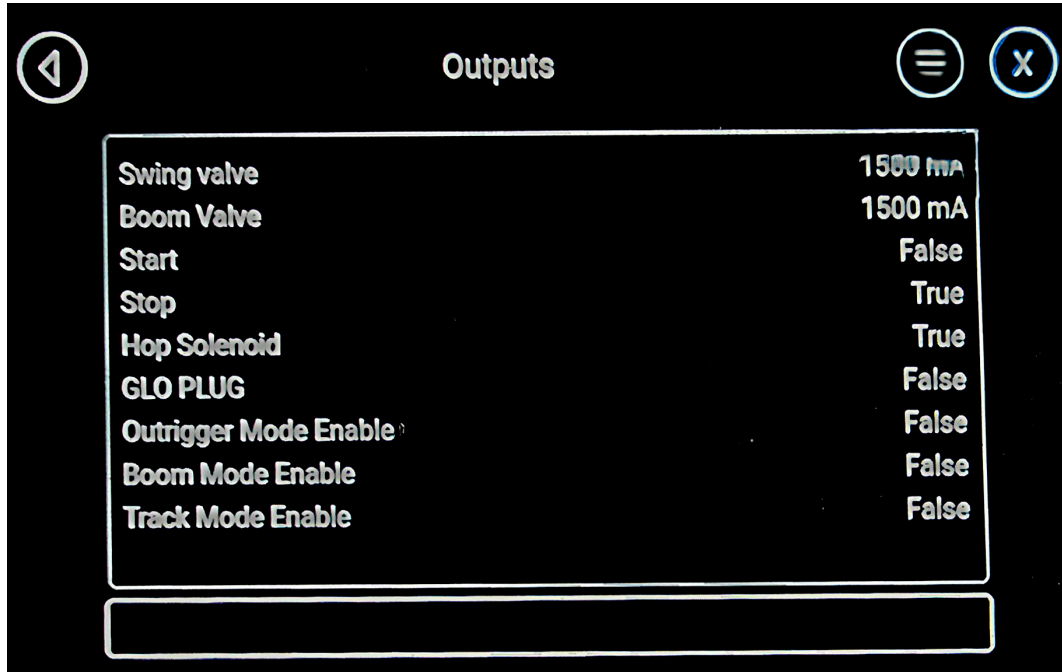

Output Display

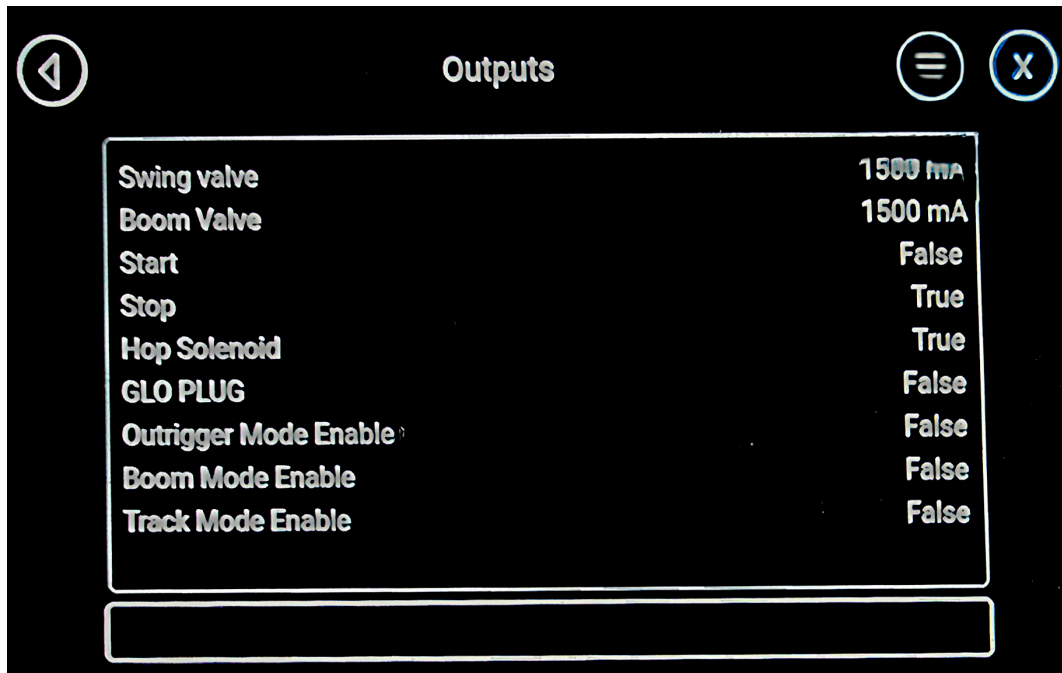

35-48DR

Operating Instructions
Starting Instructions

Hydraulic Information

Input	Value
Oil Pressure	0.67 PSI
Water Temp	36.7 °F
Alternator	False
Track Sensors	False
DI Hop Pressure	False
DI Hop Override	False
Override Keyswitch	False
Keyswitch 1	False
Pilot Pressure	-11.9 PSI
Load Sense Pressure	10.5 PSI

Settings

Swing Vlv Settings	2000 mA	...
Boom Vlv Settings	2000 mA	...
Jack PSI	700	...
Fuel Level Max Voltage	2508.00 mV	...
Fuel Level Min Voltage	900.00 mV	...

8. 12V DC Accessory

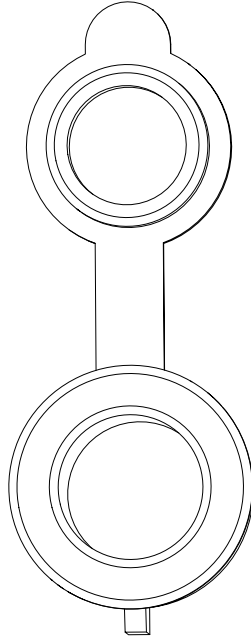

9. HOP Override

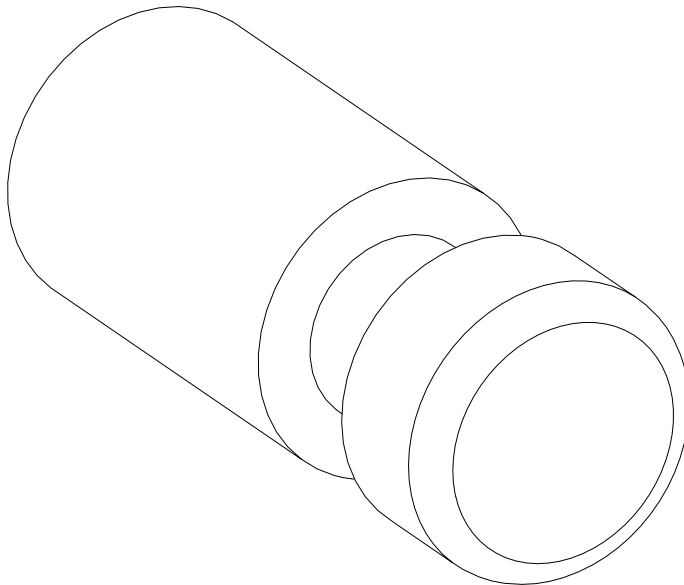

35-48DR

Operating Instructions Starting Instructions

10. Outrigger Override

The **Load King** Outback 35-48DR is equipped with an outrigger override on all machines. This override device is used to deter the Operator from operating the boom assembly without the use of outriggers. Outriggers must be deployed for any boom operation. The outrigger override is a service tool and not to be used in the field. This outrigger override enables a technician the ability to perform service procedures. This outrigger override is only to be used by a professional and under supervision. **EXTREME CAUTION** must be taken using the outrigger override on the machine, as serious injury or death can occur. **Load King** recommends contacting a **Load King** factory representative before the use of outrigger override.

The outrigger override has a key switch that activates an override of the interlock system. Once the system is activated, a warning light (RED) will illuminate and flash as well as a warning alarm will sound. These warnings will remain on as long as the system override is active. There are now **NO SAFETY GUARDS** active for operating the machine. The Operator needs to use **EXTREME CAUTION** to him/herself and their surroundings. The system is active as long as the machine's engine is running and automatically disables when the engine of the machine is shutdown. When the outrigger override is disabled, turn the key switch back to its original position (OFF). If the outrigger override is disabled via the engine shutting off and the key switch is left in the activate position, the interlock system **WILL NOT** reactivate. Return the key to the OFF position and then to the **ACTIVATE** position to activate the system.

Load King recommends that the use of this outrigger override key be highly monitored and only used when absolutely needed. **Load King** does not see a need to use this in the field and thus does not recommend to do so.

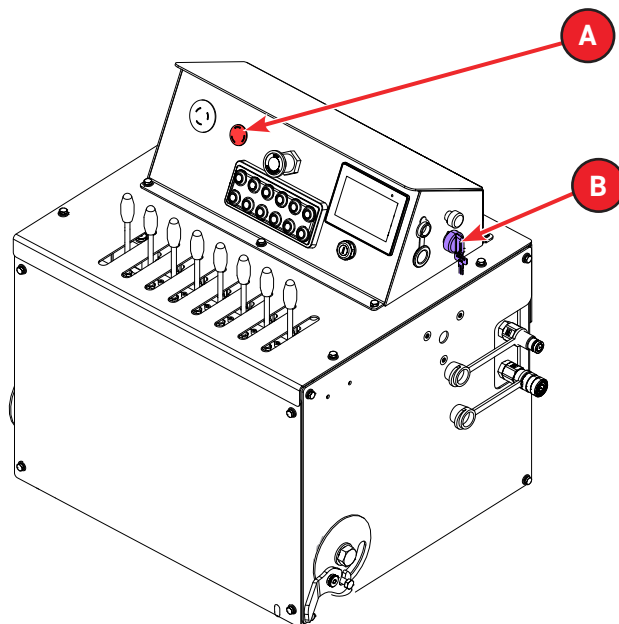

A	Warning Light And Alarm
B	Key Switch

11. Tool Circuit

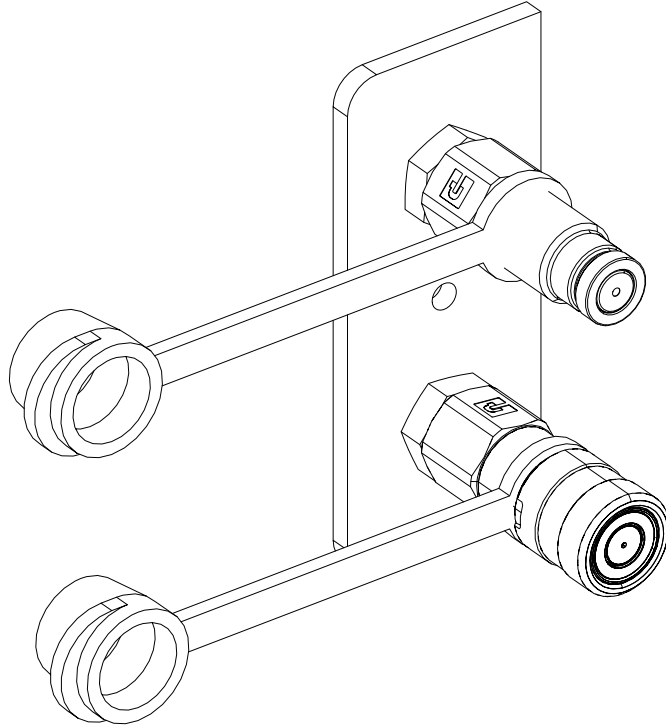

35-48DR

Operating Instructions
Accessory Instructions

Accessory Instructions

The **Load King** Outback 35-48DR has a vast selection of accessories that can be added to the machine. The following are a few quick instructions on how to operate them. If have a question about a certain option or have an issue, contact **Load King** and talk to a representative.

Wireless Radio Remote

The **Load King** Outback 35-48DR has an option to have a wireless, radio remote control. This remote allows the Operator to control the drive and boom functions. The approximate range of the remote to machine is 1,000 feet. Please refer to the Remote-Control Operation Instructions (located at the end of this manual) on how to operate the remote. If have any questions about the function of the remote or have an issue, please contact a **Load King** representative.

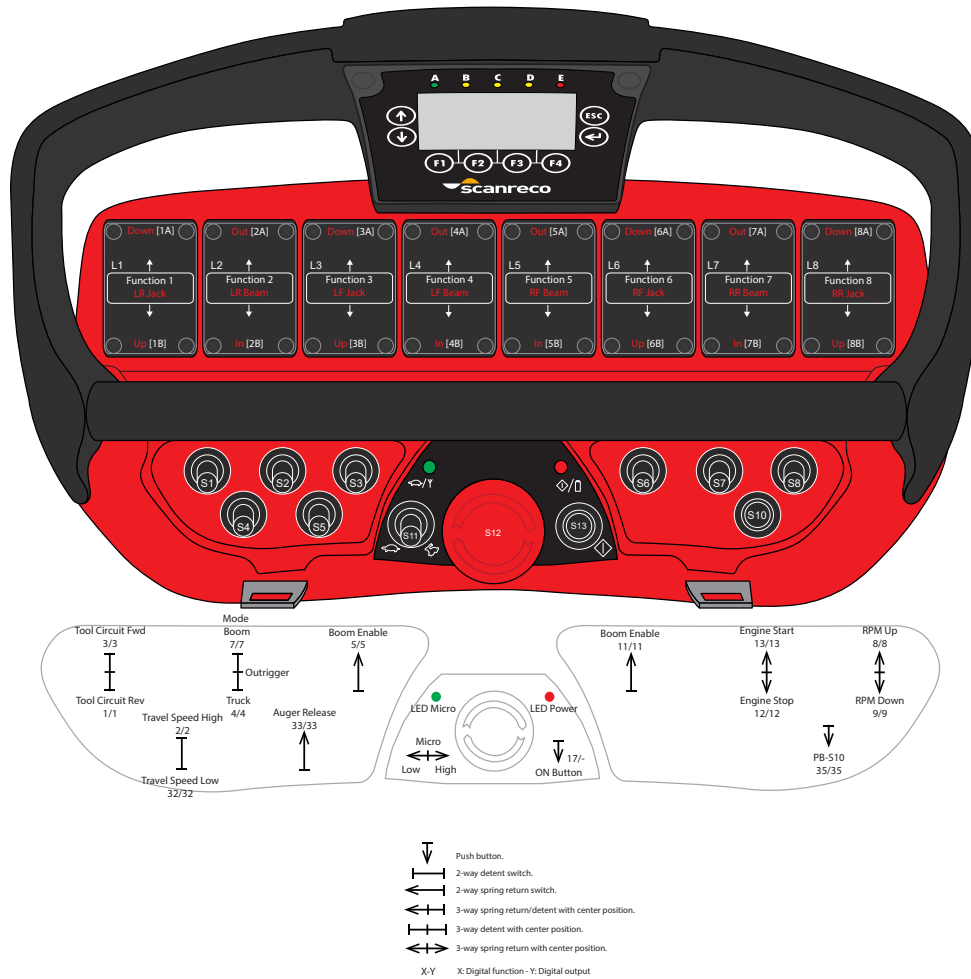

For Wireless Remote Control, Refer to Operation manual for "Scanreco Tech Spec LK 3548DR for **Load King**".

Technical Information

Track Maintenance

Due to functional necessity, the components of the undercarriage are open to soil, sand, rock, water, chemicals and the elements. Regular maintenance of the undercarriage is inevitable throughout the course of normal machine use.

Only trained personnel should perform the mounting of rubber tracks. Incorrect assembly may result in premature failure and/or damage to the machine.

Tension of Rubber Tracks

Improper tension may result in track alignment problems which could ultimately lead to de-tracking or premature failure. Tension should be inspected regularly and adjusted if necessary. Refer [Maintenance Section](#).



Loose tracks can allow excessive machine motion resulting in decreased stability during operation.

Unfavourable Terrain Conditions

Rubber tracks should not be used in certain terrains because damage can occur to the lug sides of the tracks. Some common and unfavourable terrain conditions are hard surface roads, rocky fields, stump fields, large ruts or holes, scrap rebar, troughs, crowned ridges, and along walls or border stones. Inspect the work site before beginning operation and remove any of these items when possible.

If use of the rubber tracks under any of these terrain conditions is unavoidable certain precautions can help reduce the potential for de-tracking. Drive slowly and carefully, feathering the drive controls to even out the machine speed. Avoid making sharp turns which can cause the rubber track to curl and de-track.

If rubber tracks are run up against mounds, rocks or concrete walls, a crack may occur at the edges of the rubber tracks. Avoid these circumstances whenever possible.

High abrasion soils like coarse sand and clay will unavoidably reduce track life. High moisture soil will increase the likelihood of mud packing inside the track drive and support rollers. Mud build up on rollers increases track tension; therefore, very regular clean up is required under this condition.

35-48DR

Operating Instructions Technical Information

Operating Tips

- Ideal operation is to keep both tracks equally loaded and both tracks fully and evenly supported by the ground. Since this is not always practical, manage the deviations wisely to conform as closely as possible to ideal conditions.
- Following are some tips to deal with common deviations, as well as deviations that must be avoided.
- Tight turns put torsional loads on the undercarriage. If unavoidable, alternate between left and right turns to equalize wear.
- Avoid counter rotation manoeuvres. This creates a very high stress on the tracks and undercarriage.
- Do not make sharp turns on slopes. Always stop before carefully beginning any turns.
- Avoid making quick turns on concrete roads. The high friction between the track and surface may result in de-tracking or abrasion.
- Equalize track wear by making the same amount of right and left turns, the same front to rear wear loading, etc.
- Carry only light loads on slopes when required.
- If the machine operation is dozing or similar, alternate the work cycle in both directions to equalize the wear and terrain conditions.
- Roughed and crowned surfaces place the load on the edges of the tracks. Avoid these surfaces when possible.
- When going from flat to sloped terrain, go up and down the slope, not along the slope, thereby equalizing the load on each track.
- When necessary to operate on slopes and only when safe, alternate directions so equal up slope and down slope time is put on each track.
- Avoid non-productive travel. Transport track machines by truck or trailer to the job site to prolong track life. Always work in both directions, do not back up to work only in one direction.
- Travel in reverse only when required. Less stress is applied to the track in forward and lug patterns are designed for forward travel.
- Drive slowly and carefully to avoid unfavourable terrain and obstacles that could damage the track. It is recommended to make multiple large radius turns instead of making single, sharp turns. Make "Y" turns to change direction. Avoid slipping and spinning the tracks.
- Drive carefully on rough terrain and gravel surfaces. Do not drive over sharp rocks or other obstructions that can puncture the track or concentrate forces on a small area of the track. Always strive to keep the full driving surface of the track in contact with the ground.
- Drive to avoid turning into obstacles that could contact against the frame causing structural damage. Avoid tight turns that force dirt and debris between the track and track support rollers.
- Do not allow obstructions to enter between the track and the track frame or roller support mechanism. Damage will result.

35-48DR

Operating Instructions
Operating Environments



- Never allow the edge of the track to ride up onto rocks, curbs, walls or other objects that bend the track edges. This will cause the track rubber to shear or crack along the ends of the steel inserts backbone of the track, allowing moisture and contaminants to infiltrate the track. Eventual chunking off the rubber will occur and the steel cords will corrode leading to complete failure.

Operating Environments

Temperature

The acceptable temperature range for problem free operation of standard rubber tracks is between -13°F[-25°C] and 131°F[+55°C]. If your application does not occur in this range, contact us for special rubber compounds.

Fuel & Oil Contamination

Fuel or hydraulic oil should not be allowed to come in contact with rubber tracks. If such occurs, it should be immediately wiped off or rubber deterioration may occur.

Salty Environment

Salty environments should be avoided because salt and salty air erode the adhesion of rubber to the core metals. After rubber tracks have been used in such conditions, the salt should be removed with high pressure water spray as soon as possible.

Storage

If rubber tracks are stored for long periods of time, they should be kept indoors to avoid exposure to direct sunlight and weather conditions to avoid deterioration.

Tracks should be stored on their side. Do not lay flat (as if it were on a machine) unless support has been provided to the inside of the track. This will prevent crimping in the track which could weaken the steel reinforcing cords and reduce track life.

Do not bend the track during storage or it may not track properly when installed.

PAGE INTENTIONALLY LEFT BLANK

Transportation

Unloading Machine from Trailer

Before unloading the **Load King** Outback 35-48DR from its trailer, survey the area to which the machine will be unloaded. Position trailer on level ground. Make sure the area is clear from obstructions. Perform the following steps to ensure the proper unloading technique:

1. Make sure towing vehicle is placed into "PARK".
2. Keep trailer hitched to vehicle when unloading to prevent unwanted trailer movement. Chock trailer wheels to prevent unwanted trailer movement.
3. Unpin loading ramps and ensure they are pushed to the most inward position of the trailer ramp sliding bar.
4. Lower the loading ramps to the ground.
5. Unstrap the unit from trailer with the provided winch bar.
6. Start engine of the machine.
 - ENSURE UNDERCARRIAGE TRACKS ARE FULLY EXTENDED BEFORE ANY TYPE OF TRAVEL. Failure to comply with this statement may result in serious injury or death. Tracks are only to be retracted when going through a narrow gate. Warning beeper will sound if tracks are not fully extended.
 - ENSURE BOOM IS FULLY RETRACTED AND IN THE STOWED POSITION WHILE TRAVELING. Failure to comply with this statement may result in serious injury or death. Boom is only supposed to be out of stow when all outriggers are deployed.
7. Put machine into **LOW** speed travel mode. There is a push button on the engine control panel that is labeled **Track HIGH/LOW**.
 - **Load King** recommends the machine be placed into **LOW** speed travel mode when loading and unloading the machine from the trailer.
8. Place machine into "Track" mode.
9. Cautiously back machine over loading ramps by exercising the machine drive controls.
 - When possible, use the remote control to drive the machine off/on the trailer. The remote will enable the user to operate the machine at a safe distance. Also, the user will be able to survey his surroundings.
10. Proceed to jobsite location.

35-48DR

Transportation

Loading Machine from Trailer

Loading Machine from Trailer

Before loading the **Load King** Outback 35-48DR onto the trailer, survey the area to which the machine will be driven on. Position trailer on level ground. Make sure the area is clear from obstructions. Keep trailer hitched to vehicle when loading to prevent unwanted trailer movement. Perform the following steps to ensure the proper loading technique:

1. Make sure towing vehicle is placed into **PARK**.
2. Chock trailer wheels to prevent unwanted trailer movement.
3. Unpin loading ramps and ensure they are pushed to the most inward position of the trailer ramp sliding bar.
4. Lower loading ramps to the ground and ensure the trailer deck is clear of obstacles or tools.
5. ENSURE MACHINE'S UNDERCARRIAGE TRACKS ARE FULLY EXTENDED BEFORE ANY TYPE OF TRAVEL. Failure to comply with this statement may result in serious injury or death. Tracks are only to be retracted when going through a narrow gate. Warning beeper will sound if tracks are not fully extended.
6. Put machine into **LOW** speed travel mode. There is a push button on the engine control panel that is labeled **Track HIGH/LOW**.
 - **Load King** recommends the machine be placed into "**LOW**" speed travel mode when loading and unloading the machine from the trailer.
7. Place machine into "Track" mode.
8. Cautiously drive machine over loading ramps by exercising the machine drive controls.
 - When possible, use the remote control to drive the machine **off/on** the trailer. The remote will enable the user to operate the machine at a safe distance. Also, the user will be able to survey his surroundings.
9. Drive machine onto trailer until track undercarriage comes in contact with track stop located on the trailer. This track stop is positioned for the correct tongue weight of the trailer. Moving this track stop will alter the tongue weight of the trailer thus hindering trailer stability. DO NOT MOVE track stop.
10. Turn machine engine off.
11. Strap the machine down to its trailer before transporting the **Load King** Outback 35-48DR.

Maintenance



Never attempt to clean, adjust or lubricate a track unit while it is in motion. Failure to do may result in serious personal injury or death.

General

Proper tension of the rubber track is essential for maximum track and undercarriage life and will result in less down time. Refer [Adjustments](#).

Over tightening track can accelerate undercarriage bearing wear and overstress and stretch or crack the rubber track allowing contaminants to deteriorate the rubber compound and steel reinforcing components.

Loose tracks can derail during turning and can also reduce machine stability during operation. It is also possible for the drive sprocket to slip over the belt driving lugs causing wear to the rubber track and possible failure. Derailing causes track damage. Never repair with used or worn components (idler, sprocket, rollers).



Loose tracks will allow excessive machine motion resulting in decreased stability during operation.

Lubrication

Different OEM brand hydraulic wheel motor drives are used on track unit assemblies, but the lubricating procedure is similar.

1. Park the unit so the fill plug is at the top. Some units will have a plug identified as "FILL". If the plug is not identified, the two opposite plugs are the same and either can be positioned at the top.
2. Check oil level at center check plug. Oil should seep out when plug is removed. Top off if required.
3. Lubrication Specifications: Consult the wheel motor manufacturer's instructions for the proper lubricant, quantity and operating temperature range.

35-48DR

Maintenance
Adjustments

Adjustments

Inspect Tension

Check the tension at the tensioner viewport to ensure the engraved tensioner ring is in the correct position. The engraved tensioner ring should be flush with the tensioner mount plate. If the engraved tensioner ring is not in the correct location, it is necessary to adjust tension to prevent damage to the tracks.

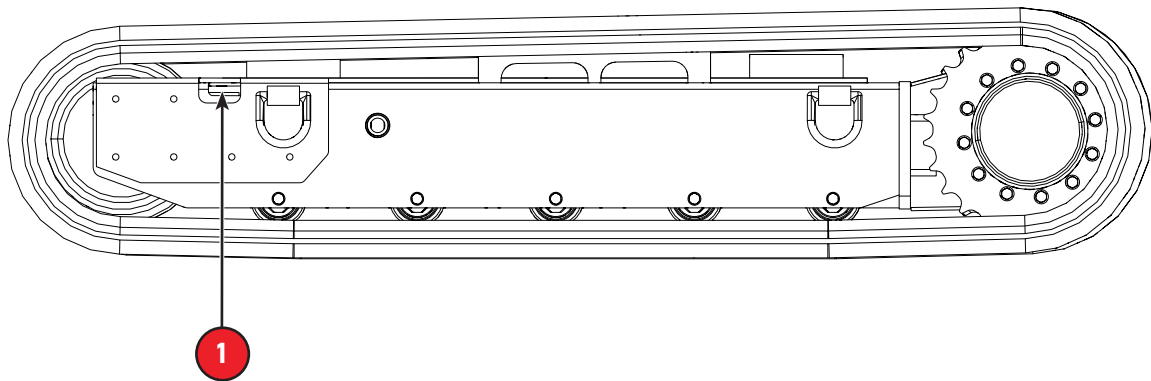

1	Tensioner View Port
---	---------------------

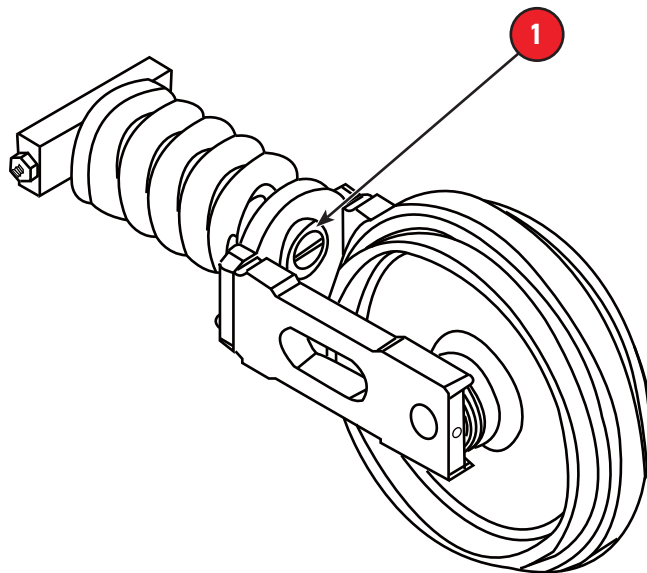

Not Properly Tensioned

1	No tension on compression spring (Engraved tensioner ring is not exposed)
---	---

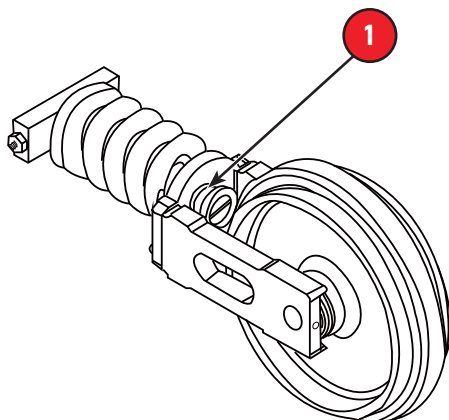

Correctly Tensioned

1	Engraved Tensioner Ring Exposed
---	---------------------------------

Adjust Tension

1. Remove the protective plug that covers the grease relief valve.
2. Support track assembly so the track clears the ground.
3. Apply a standard grease gun to the grease valve fitting (zerk) and slowly pump grease to extend the track tensioner against the compression spring.
4. The grease valve has a check valve behind the zerk to prevent grease from coming back under pressure. If it is necessary to release track tension, turn the check valve CCW a few turns until the grease is allowed to expel. Retighten when complete.
5. Lower the track back onto the ground and replace the protective plug.

Cleaning

Keep driving system cleaned and properly maintained. Remove any debris or mud which could interfere with the operation of the machine.

If mud and debris is allowed in the undercarriage, it can plug the spring-loaded tensioner preventing it from relieving stress on the track when traveling over irregular surfaces. Mud can build up on the track rollers thereby over-tensioning and stretching the track or the rollers can stop turning and then scrub on the track creating wear and failure.

Wash fuel and oil from the tracks.

Repair

In order to prevent bonding or corrosion failures, tracks should be repaired immediately when damaged.

Minor cracks in the rubber can be filled with rubber repair compound.

Once the steel cords have failed, the track is no longer serviceable.

Track Drive Motor

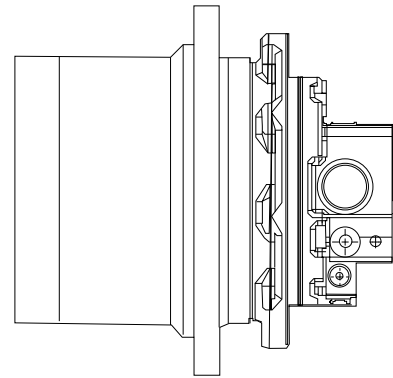
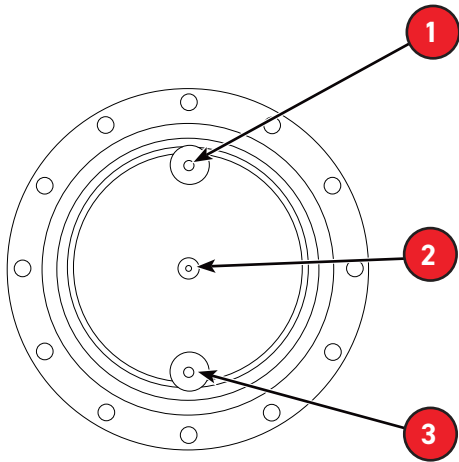
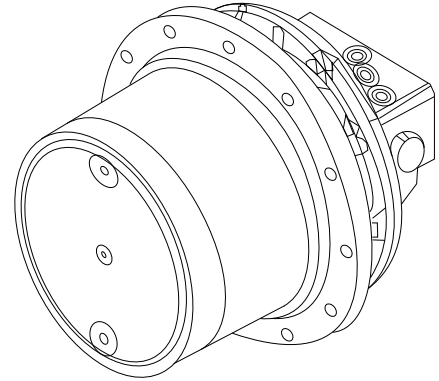
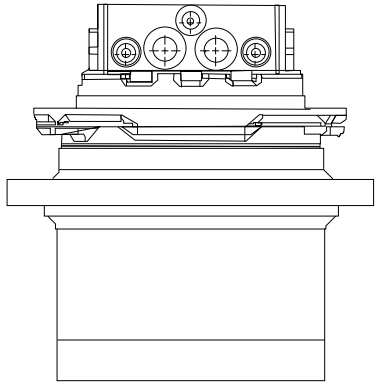

Sr No	Ports	Tightening Torque
1	Oil Supply Port	34-38 ft-lb
2	Oil Level Check Port Plug	9-13 ft-lb
3	Oil Discharge Port	34-38 ft-lb

Lube Requirements	
Quantity	1000cm ³
Lube Type	80W-90 Gear Lube
First Change	200 Hours or 2 Months
Second and after Change	1000 Hours or 1 Year

Boom Maintenance

Description

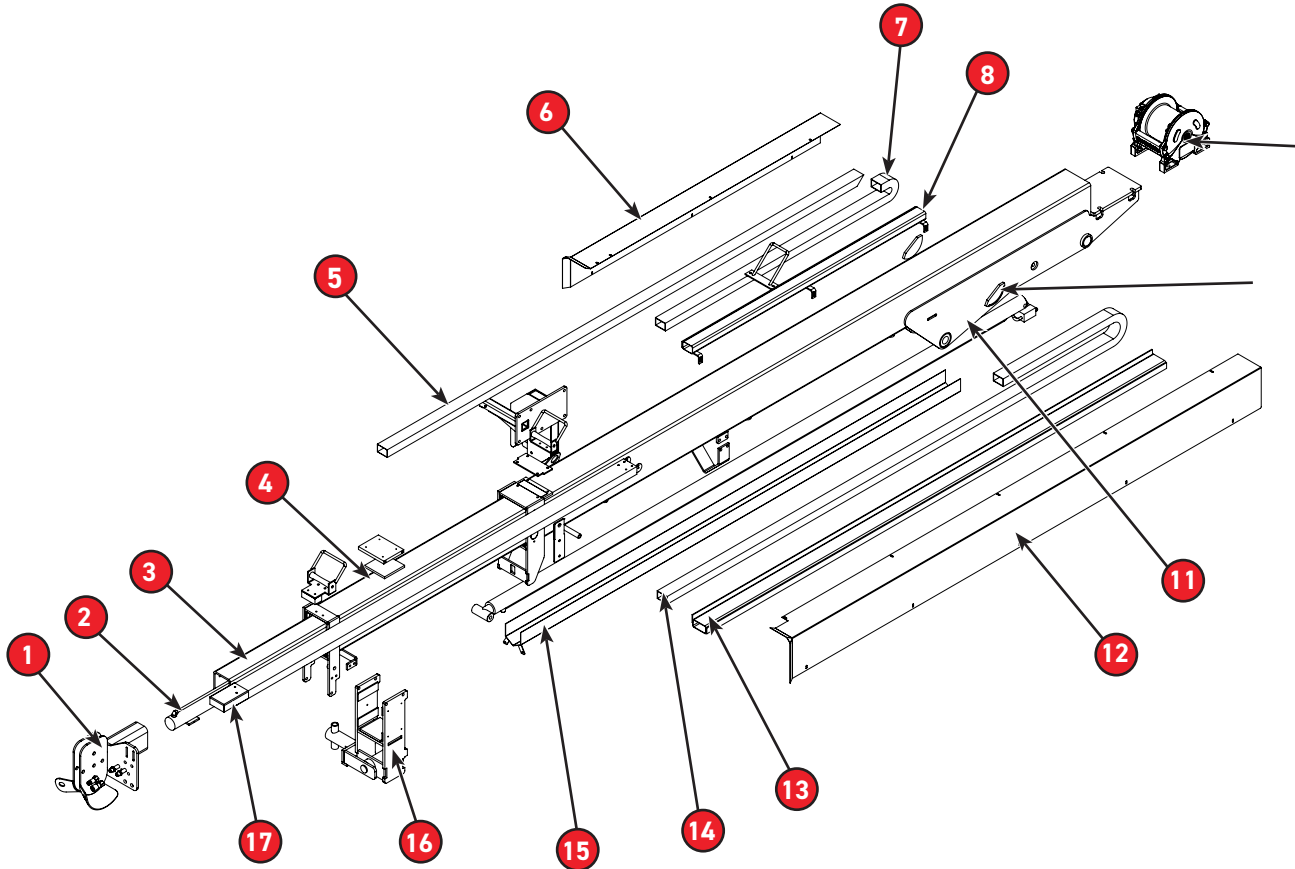

Item Number	Description	Item Number	Description
1	Shimless Sheevehead	10	Inclinometer, Left
2	Fiberglass Boom Ext Cyl	11	Main Boom
3	Fiberglass Boom W/ Wear Pads	12	Cattrack Cover, Large
4	Secondary Boom	13	Cattrack Support Tube-Long
5	Floating Cattrack Auger Tube	14	Cattrack, Steel
6	Small Cattrack Cover	15	External Cylinder Cover
7	Auger Cattrack, Plastic	16	Auger Hanger
8	Auger Cattrack Tube Assembly	17	Fiberglass Hose Carrier Tube
9	Main Boom Winch		

35-48DR

Maintenance

Maintenance Issues with Fiberglass Booms

Maintenance Issues with Fiberglass Booms

The Most Common Maintenance Issues with Fiberglass Booms

1. Not keeping the boom clean inside and out
 - A dirty boom does not shed rain as well and can fail periodic dielectric tests.
2. Cleaning with harsh abrasive cleaners
 - Abrasives and solvent cleaners are not recommended as they can scratch or soften the surface coatings. There are a number of cleaners recommended for cleaning booms or soap and water can be used. Consult the service department of the manufacturer for their recommendations.
3. Washing with high-pressure water
 - This can cause water to diffuse through the fiberglass requiring elevated temperatures or extended time to dry out. Wash by hand and park the boom in a position that allows water to drain. A boom dielectrically tested while it is still wet can cause permanent damage.
4. Surface cracks due to weather, age or improper paint preparation
 - These kinds of problems will require refinishing. However, refinishing the exterior of the booms without masking the interior can cause paint overspray to settle on the inside. Research has shown that this overspray will trap moisture and prevent water from beading on this rough, sandpaper-like surface. This moisture can then lead to failed dielectric tests.
5. Dielectric testing over 1mA (1000 micro-amps) return current
 - This process can harm the boom by causing it to burn. If the return current is closed to 1000 micro - amps during the dielectric test, stop the test immediately and examine the boom for any hot spots present. Examine the boom for any contamination such as; dirt, moisture, sticks or other debris. Let the boom cool and remove the contamination. (Dirt or moisture can cause the fiberglass to be burnt beyond repair.)
6. Overloading
 - Even if the boom does not break, overloading can cause stress cracks and shorten the life of the fiberglass boom. A single overload can shorten a booms service life by months or years. A boom used at the rated load should remain in service for many years.
7. Not strapping down the boom during travel
 - Subjecting a boom to repeated jolts can shorten the life of the fiberglass. This shock loading will fatigue the fiberglass and can create impact damage in the area of the boom rest.
8. Cable cuts and saw cuts
 - Cuts can weaken the boom in the specific area of the damage. Consult the manufacturer before repairing this type of damage.
9. Sunshine and ultraviolet radiation
 - Sunlight and UV can attack an unpainted area of a fiberglass boom causing the exposed area to look fuzzy as the fibers are exposed. Repair surface scratches, to seal out the sun and moisture, to prevent this problem.

10. Improper repairs

- Using substandard material and improper repair procedures can cause problems. There are two types of repairs. The first is periodic surface repair that involves the outside coating. Second is the structural repair that involves the boom itself. Structural repair should be referred to the manufacturer for a case-by-case study. Examples of structural damage include: cracks, cuts, delamination and impact damage from tree limbs or tools.

11. Improper storage

- Storing fiberglass booms in direct sunlight, untarped or covered, and directly on the ground are both methods of improper storage which could cause blistering and dielectric failure. Improper storage could also void the warranty. Storage of booms should always be off the ground for air ventilation and away from direct sunlight.

PAGE INTENTIONALLY LEFT BLANK

Checklist and Inspection Forms

Machine Inspection Chart

This checklist is to be used in addition to the information provided in this manual to properly operate and maintain the machine.

	This inspection intervals are recommended by Load King . If there are further maintenance questions, contact Load King .
---	--

INSPECTION	SERVICE	DAILY	WEEKLY	3 MONTHS	6 MONTHS	1 YEAR
Hydraulic Oil	Check level	X				
	Drain oil and replace					X
Hydraulic Return Filter	Replace				X	
Hydraulic Hose(s) & Fittings	Check for leaks/cracks. Repair leaks immediately.	X				
Engine Oil	Check level	X				
	Change oil (check engine manual)					
Engine Air Filter	Clean and inspect	X				
Track Undercarriage	If equipped: Check track tension(er)	X				
Track Undercarriage Slide Bars	Grease slider bar contact area		X			
Boom	Grease all fittings		X			
Main Boom Lift Cylinder	Grease fittings with an EP grease			X		
Nylon Sheaves	Check for sharp edges and cuts		X			
Rotation Bearing	Check torque on bolts	X				
Rotation Bearing Bolts	Check torque on bolts. Torque to 159 ft-lbs.			X		
Rotation Bearing	Grease with an EP grease			X		
Outriggers	Grease all fittings, sockets and pins	X				
Winch Line Hook	Inspect hook and latch	X				
Winch Line	Inspect for wear and broken strands	X				
Auger Strap	Inspect for wear and broken strands	X				
Pin Retainers	Make sure pin retainers are in place and tightly bolted	X				
Tie Down Hooks	Make sure bolts are tight	X				
Wheel Lug Nuts	If equipped: Make sure bolts are tight	X				

www.loadkingmfg.com

35-48DR | Operator's Manual

Load King

7701 Independence Ave.

Kansas City, MO 64125

Parts: (816) 241- 8387

Service: (833) 281-7911

Email: info@loadkingmfg.com