

LOAD KING



OPERATORS MANUAL

LOAD KING

25-92M

Page Intentionally Blank

WARNING Operating, servicing and maintaining this equipment can expose you to chemicals including engine exhaust, carbon monoxide, phthalates, and lead, which are known to the State of California to cause cancer and birth defects or other reproductive harm. These chemicals can be emitted from or contained in other various parts and systems, fluids and some component wear by-products. To minimize exposure, avoid breathing exhaust, do not idle the engine except as necessary, service your equipment and vehicle in a well-ventilated area and wear gloves or wash your hands frequently when servicing your equipment or vehicle and after operation. For more information go to www.P65Warnings.ca.gov/passenger-vehicle.

Breathing diesel engine exhaust exposes you to chemicals known to the State of California to cause cancer and birth defects or other reproductive harm.

- Always start and operate the engine in a well-ventilated area.
- If in an enclosed area, vent the exhaust to the outside.
- Do not modify or tamper with the exhaust system.
- Do not idle the engine except as necessary.

For more information go to www.P65warnings.ca.gov/diesel.

Company

Load King has been producing first-class heavy equipment since 1956. Cutting-edge innovation and engineering excellence make us the market leader. Load King is a key part of the Custom Truck One Source family of brands, offering standard and custom trailers, vocational equipment, and a full line of Boom Trucks and truck cranes. For more information, please visit Load King's website: www.loadkingmfg.com.

About Custom Truck One Source

Custom Truck One Source is the first true single-source provider of specialized truck and heavy equipment solutions. With sales, rentals, aftermarket parts and service, equipment customization, remanufacturing, financing solutions, and asset disposal, our team of experts, vast equipment breadth and integrated network of locations across North America offer superior service and unmatched efficiency for our customers.

Table of Contents



Introduction	5
Construction and Industrial Equipment Product Safety.....	5
Nomenclature.....	6
Standards.....	7
Intended Use.....	8
Bulletin Distribution and Compliance.....	9
Contacting Manufacturer.....	10
Transfer of Machine Ownership.....	11
Safety	13
Safety Introduction.....	13
Product Safety Decals	14
Safety Sign Maintenance	19
Personal Protection Equipment	20
Workplace Safety	21
Effects of Wind Conditions	30
Lightning Storm.....	32
Temporary Interruption of Crane Operations.....	33
Resuming Crane Operations.....	36
Ending Crane Operations.....	37
Turning/Driving in Reverse	38
Parking the Vehicle	39
Lock Out & Tag Out	40
Access/Egress	42
Personal Safety	45
Seat Belts.....	46
Assembly.....	47
Wire Rope Reeving	47
Dead Ending Wire Rope in Socket.....	49
Jib Mounting	50
Description Of Machine and Controls.....	63
Power Take-Off	63
Controls.....	64
Outrigger Stow Pins	65
Outrigger Controls.....	67
Boom and Winch Controls.....	69
Front Stabilizer	71
Rated Capacity Indicator and ATB	73

&!- &A

Contents

Rated Capacity Indicator System	73
ATB Components	74
Inspection.....	77
Pre-Start Inspection	77
Suggested Hydraulic Crane Inspection Checklist	69
Daily Check (8 Hours).....	84
Weekly Check (40 Hours).....	85
Monthly Check (80 hours)	86
Quarterly Checks (250 Hours)	87
Semiannual Checks (1000 Hours).....	88
Annual Check (1500 - 2000 Hours)	89
Crane Boom.....	90
Wire Rope Inspection.....	93
Wire Rope Inspection Record	95
Mobile Crane Load Test Inspection	96
Operating Instructions.....	99
Job-Site.....	99
Job Site Setup Procedure.....	99
Outrigger Positioning	100
Work Site Position	101
Cold Weather Operation	102
General Operational Issues	103
General Rules.....	103
Safety Devices	105
Training and Operator Qualifications	106
Operator Aids.....	107
Load Handling Operations	108
Max. Load and Boom Angle Charts.....	109
Using the Maximum Load Chart.....	109
Operating Radius	111
Boom Angle Placards	112
Operating the Unit.....	113
Operating the Unit.....	113
Initiating Operation.....	114
Arm and Hand Signals	115
Lifting the Load	119
Emergency Procedures.....	120
Emergency Procedures	120

Emergency Boom Retraction.....	121
Emergency Lowering of Boom	122
Emergency Rotation.....	123
Emergency Retraction of Outriggers.....	124
Rooding the Unit.....	125
Maintenance.....	137
Safety Practices.....	137
Cold Weather Package Specification.....	129
General Work Practices	130
Storing Components.....	131
Cleanliness.....	132
25-92M Master Lube Chart.....	133
Maintenance Checks and Lubrication	136
Hydraulic Oil Requirements	139
Hydraulic Hoses.....	143
90-Day Maintenance Items	145
Semi-Annual Maintenance Items	146
Filters and Maintenance.....	147
Rotation System Maintenance and Troubleshooting.....	150
Swing System	150
Care and Maintenance of the Rotation System.....	152
Rotation Gearbox and Gear Teeth.....	155
Swing (WAD/ISS) Sensor Check & Replacement Procedure	157
Winch Lubrication	163
Wire Rope Lubrication	164
Storage.....	165
Storage	165
Restoration to Service	167
Engine Storage	168
Restoring Engine to Service.....	171
Transmission storage.....	172
Restoring Transmission to Service	173
Chrome Cylinder Rod Storage.....	174
Specifications.....	175
Pumps and Function Speeds.....	175
Troubleshooting	179
Troubleshooting	179
Winch System Maintenance and Troubleshooting	180

&!- &A

Contents

Winch Maintenance and Repair.....	181
Two-Speed Winch Function.....	182
Service / Parts.....	185
Hydraulic System Description.....	185
Control Valves and Pressures.....	187
Outrigger and Cylinder Maintenance and Troubleshooting.....	192
Outrigger Position Sensors.....	192
Lift Cylinder.....	196
Outrigger Cylinder.....	197
Extension Cylinder.....	202
Boom Maintenance, Adjustment and Repair.....	206
Wear Pad Adjustment and Replacement.....	206
Boom Reassembly.....	213
Boom Cable Adjustment Procedure.....	223
Rotation Gear and Gearbox.....	226
Removal/Installation of Rotation Gear and Gearbox.....	226
Inspection of Rotation Bearing Clearance.....	228
Backlash Adjustment.....	230
Internal RCI Cable Repair.....	232
Appendix.....	237
Conversion Tables.....	237
Average Weight of Materials.....	241
Torque Specs -SAE & Metric.....	243
Personnel Platform Installation & Operation Manual.....	245
Greer Insight Operation's Manual.....	246

Construction and Industrial Equipment Product Safety

It is the responsibility of the owner of the equipment to be knowledgeable about federal, state and local regulations that effect the total usage of the equipment, and responsibility to working personnel and the public. Since regulations are subject to change, and also differ from one locality to another, this manual makes no attempt to provide such information.

Load King provides appropriate operation and maintenance manuals for various construction and industrial equipment products that it manufactures and sells. In addition, where applicable, appropriate national consensus standards, industry standards and safety related manuals are included with the Load King manuals in the shipment of each product. It is company policy to provide this information for the owner or user of the equipment. It is expected that the owner or user will utilize these manuals and standards to provide the appropriate information and training to those people who are to operate, maintain and supervise the use of equipment.

Construction and industrial equipment is designed and manufactured to perform heavy-duty work. Under normal usage, the equipment will wear. For this reason it is essential that the owner/user establish and perform a periodic inspection of the equipment. The objective of inspection programs is to prevent accidents, reduce downtime and keep the equipment working efficiently. These inspection programs should be designed to discover worn, cracked, broken or deteriorated parts and loose or missing fasteners before they result in a problem.

Proper training and inspection programs are essential to avoiding injury to persons, damage to property and excessive maintenance costs.

Read and understand the manuals provided with this equipment. Assistance is available from the distributors of your Load King product and from the Load King manufacturing facility.



When operating a hydraulic crane, the operator should realize that hydraulic and structural competence, **NOT TIPPING LOAD**, is often the determinant of lifting capacity. Therefore, **THE OPERATOR MUST BE GUIDED SOLELY BY THE APPROPRIATE MANUFACTURER'S LOAD RATING CHART** when considering load weights. The manufacturers rated loads must never be exceeded.

Follow the recommended operating and maintenance procedures and keep your machine operating at **MAXIMUM EFFICIENCY**. Use the Suggested Inspection Check List provided. In addition, a **MAINTENANCE LOG** should be kept in conjunction with all maintenance performed on the machine.

If you desire any special information regarding the care and operation of the machine, we will gladly furnish it upon request. We ask that you include your machine model and serial number in all correspondence so that we can provide the correct information.

The information, specifications, and illustrations in this publication are based on the information in effect at the time of approval for printing. We reserve the right to make changes at any time without obligation.

Nomenclature

This manual contains instructions and information on the operation, maintenance, lubrication and adjustments of the Boom Truck. The operator should not attempt to operate the machine before he has gained a thorough understanding of the material presented in the following pages. To aid in understanding the contents of this manual, the following terms will always have the meanings given whenever they are used.

- | | |
|---------------|--|
| 1. TURRET | The turret weldment and swing mechanism. |
| 2. BOOM | The telescopic boom with hydraulic winch, lift cylinder, hook block assembly, and jib arrangement. |
| 3. PEDESTAL | The structure that supports the turret weldment, outriggers, and operator platforms on the truck. |
| 4. FLATBED | The deck of the Boom Truck. |
| 5. SUBFRAME | The frame of the crane that is mounted to the truck chassis and supports the flatbed and pedestal. |
| 6. OUTRIGGERS | The beams, cylinders, floats, boxes, hydraulic control system. |
| 7. TRUCK | The vehicle that all boom and operator structures are mounted on. |
| 8. ATB | Anti-Two Block |
| 9. RCI | Rated Capacity Indicator |

RIGHT HAND/LEFT HAND

All references to right or left hand will correspond to the operator's right or left hand when he is facing forward from the operator's platform, with the truck cab to his back.

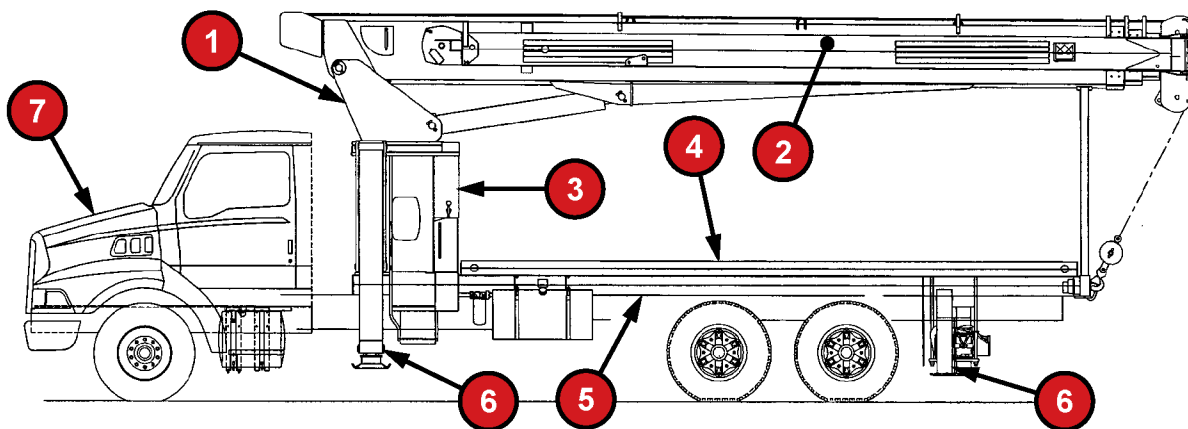

Standards

Many aspects of crane operation and testing are discussed in standards published by the American National Standards Institute. These Standards are updated on an annual basis with addendum, which are sent by American Society for Mechanical Engineers (ASME) to the original purchasers of the standard. Load King® recommends that you purchase and refer to the following standards:

ANSI/ASME B30.5 – Mobile & Locomotive Crane (Latest Version)

These standards may be purchased by:

Mail: American Society of Mechanical Engineers"
Customer Service Department
22 Law Drive
Fairfield, New Jersey 07004

Phone: 800.843.2763

Internet: www.asme.org

Copyright

This manual is intended for use by personnel responsible for operation, maintenance, repair and supervision activities involving the machine described within.

This manual is copyrighted. It shall not, either in whole or in part, be reproduced, transmitted, or used for the purpose of competition without our prior written consent.

Intended Use

This mobile crane is designed to lift, lower, move, and position freely suspended loads within its rated capacity while on firm, level ground. The crane is designed exclusively for assembly type, non-duty cycle operations. Use of this product in any other way is prohibited and contrary to its intended use.

Other crane applications outside of the intended use statement above must be approved in writing by Load King.

Bulletin Distribution and Compliance

Safety of product users is of paramount importance to Load King. Various bulletins are used by Load King to communicate important safety and product information to dealers and machine owners.

The information contained in bulletins is tied to specific machines using the machine model number and PIN/serial number.

Distribution of bulletins is based on the most current owner of record along with their associated dealer, so it is important to register your machine and keep your contact information up-to-date.

To ensure safety of personnel and the reliable continued operation of your machine, be sure to implement the action indicated in a respective bulletin.

Contacting Manufacturer

At times it may be necessary to contact the manufacturer of this machine. When you do, be ready to supply the model and PIN/serial number of your machine, along with your name and contact information. At minimum, the manufacturer should be contacted for:

- Accident Reporting
- Questions regarding product applications and safety
- Standards and regulations compliance information
- Questions regarding product modifications
- Current owner updates, such as changes in machine ownership or changes in your contact information (see Transfer of Machine Ownership, in this chapter, for more information).

Manufacturer contact information:

Load King

7701 Independence Ave, Kansas City, MO

64125

Parts: (816) 241- 8387

Service: (833) 281-7911

Email: info@loadkingmfg.com

Transfer of Machine Ownership

Complete the New Owner Registration Form on the following page. The Model Name, Product Identification Number (PIN), and serial number is located on a plate inside the operator's cab. The six digit serial number is shown on a plate on the outside of the operator's cab on the RS models and on the product identification plate on the side of the main frame in the street side operator's stand.



LOAD KING WARRANTY DATA RECORD

Warranty Form Submission		Date	
Date of Delivery			
Model Number			
S/N			
Dealer			
Address			
Customer			
Address			

Record this information at the time that warranty registration form is completed and returned to Load King

Safety Introduction

Owners, Users, and Operators:

Load King appreciates your choice of our machine for your application. Our number one priority is user safety, which is best achieved by our joint efforts. We feel that you make a major contribution to safety if you, as the equipment users and operators:

1. **Comply** with OSHA, Federal, State, and Local Regulations.
2. **Read, Understand, and Follow** the instructions in this and other manuals supplied with this machine.
3. **Use Good, Safe Work Practices** in a common sense way.
4. **Only have trained and competent operators**, directed by informed and knowledgeable supervision, running the machine.



OSHA prohibits the alteration or modification of this crane without written manufacturer's approval. Use only factory-approved parts to service or repair this unit.

If there is anything in this manual that is not clear or you believe should be added, please send your comments to Load King Cranes, 7701 Independence Ave, Kansas City, MO 64125; or contact us by telephone at Parts: (816) 241- 8387 Service: (833) 281-7911
Email: info@loadkingmfg.com



THIS SYMBOL MEANS YOUR SAFETY IS INVOLVED! READ, UNDERSTAND, AND FOLLOW ALL DANGER, WARNING, AND CAUTION DECALS ON YOUR MACHINE.

Many aspects of crane operation and testing are discussed in standards published by the American National Standards Institute. These Standards are updated on an annual basis with addenda, that are sent by ASME to the original purchasers of the standard. Load King recommends you purchase and refer to the following standards.

ANSI/ASME B30.5 - Mobile & Locomotive Crane (Latest Version)

These standards can be purchased from:





American Society of Mechanical Engineers
Two Park Avenue
New York, NY 10016-5990
800-843-2763 (U.S./Canada)
001-800-843-2763 (Mexico)
973-882-1170 (outside North America)

Email:









CustomerCare@asme.org
www.ASME.ORG/SHIP/STANDARDS



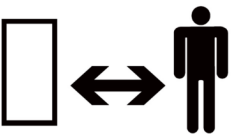

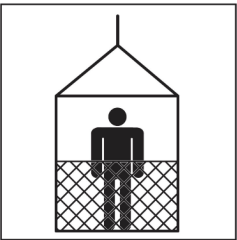

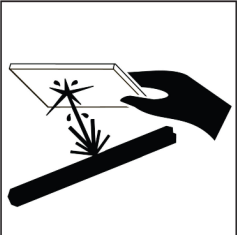
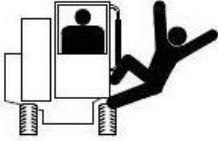
Safety Definitions Used in this Manual

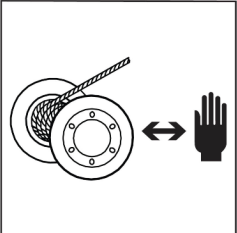

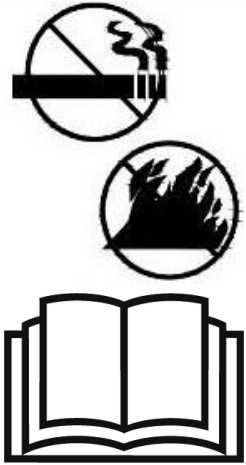

The following table describes text and symbols used to highlight important information.

Signal Word	Symbol	Explanation
DANGER		Danger is used to alert readers about an immediate and serious hazard that will likely be fatal.
WARNING		Warning is used to alert readers about the potential for serious injury or death or serious damage to equipment.
CAUTION		Caution is used to alert readers about the potential for anything from moderate injury to serious equipment damage or destruction.
READ		Read is used to alert readers of information to be read on machinery
NOTE		Note is used for a tip or suggestion to help readers carry out a procedure successfully.

SYMBOLS AND PICTORIALS

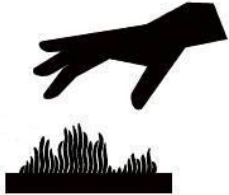
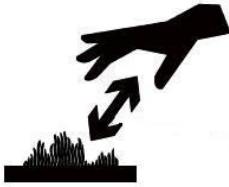
Hazard		Avoidance	
	<p>CRUSH HAZARD</p> <p>Crushing of fingers or hand - force applied two directions (pinched).</p>		<p>Stay Clear of Moving Turret and Boom.</p>
	<p>CRUSH HAZARD</p> <p>Death or Serious Injury can result from contact with moving machine.</p>		<p>Keep clear of moving machine.</p>
	<p>Safety Alert Symbol</p>		<p>Use personnel lift in compliance with OSHA and ANSI regulatory instructions.</p>
	<p>Skin Injection From High Pressure Fluid.</p>		<p>Use Cardboard or Wood to Check for Leaks.</p>
	<p>Falling From Wheeled Machine.</p>		<p>NO RIDERS</p>
	<p>Hand Entanglement In Pulley / Winch.</p>		<p>Keep Hands Clear of Winch and Load Line.</p>

Hazard		Avoidance	
	<p>Entanglement in Drive Shaft.</p>		<p>Stay Clear of Rotating Shafts.</p>
	<p>ENTANGLEMENT HAZARD Rotating parts can cause personal injury.</p>		<p>Keep away from fan and belt when engine is running. Stop engine before servicing.</p>
	<p>Explosion / Burn Hazard Will cause death, burns or blindness due to ignition of explosive gases or contact with corrosive acid.</p>		<p>Keep all open flames and sparks away. Wear personal protective equipment, including face shield, gloves and long sleeve shirt.</p> <p>READ MANUALS Read all manuals prior to operation.</p> <p>DO NOT OPERATE equipment if you do not understand the information in the manuals.</p>
	<p>BURN HAZARD Fuel and fumes can explode and burn.</p>		<p>No smoking. No flame. Stop engine.</p>

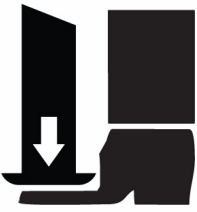
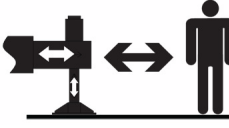
Hazard		Avoidance	
	<p>BURN HAZARD Contact with hot surfaces can cause burns.</p>		<p>Allow surfaces to cool before servicing.</p>
	<p>Falling from height.</p>		<p>Use personnel lift or appropriate ladder to reach high places.</p> <p>Maintain 3-Point Contact when using access system.</p>
	<p>Two blocking the crane can cause death, serious injury or property damage. Do not allow the hook block to contact the boom tip by hoisting up, extending or lowering the boom.</p>		<p>Check ATB System.</p>
	<p>CRUSH HAZARD Contact with moving outriggers can result in death or serious injury.</p>		<p>Stay Clear of Outriggers.</p>

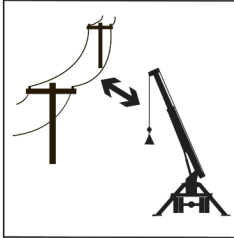
Hazard		Avoidance	
	<p>Electrical Shock / Electrocutation from Crane to Power Line Contact.</p>		<p>Stay Sufficient Distance From Electrical Power Lines.</p>

	<p>These are general safety rules, that must be followed. You are also required to read and understand the Operators Manual as there are instructions that are more detailed, specific to this machine.</p>
---	---

Safety Sign Maintenance

Replace any missing or damaged safety signs. Keep operator safety in mind at all times. Use mild soap and water to clean safety signs. Do not use solvent-based cleaners because they will damage the safety sign material.

Personal Protection Equipment

Before beginning operation, service or maintenance conduct a hazard assessment to determine appropriate personal protective equipment for the working conditions and the operating environment. For more information refer to the applicable OSHA 1910.132 Standards, ANSI Standards, Federal, State, Local and Jobsite Regulations.

Common Types of PPE



Safety Glasses – Impact resistant lenses offering limited protection for the user’s eyes from flying debris.



Ear Plugs – A device that is inserted into the ear canal to protect the user’s hearing from loud noises or the intrusion of foreign bodies and dust.



Hard Hat – A helmet used to protect the user’s head from injuries obtained from falling objects and debris.



Leather Gloves – Gloves used to protect the user’s hands from minor cuts and other injuries.



Safety Boots – A boot designed to protect the user’s feet from various types of injury such as cuts, puncture wounds, crushed toes, etc.

Workplace Safety



HANDLING PERSONNEL

Cranes can only be used to lift people when it is the least hazardous way to do the job. (See OSHA 1926.1431, 1926.550g, and ASME / ANSI B30.23.)



TRAINING AND KNOWLEDGE

1. Safe operation must always be the operator's most important concern.
2. Do not operate this crane until you have been trained in its operation. This crane must only be operated by trained personnel, who have demonstrated their ability to do so safely.
3. Comply with the requirements of current Occupational Safety and Health Administration (OSHA) standards, the current ASME B30.5 (latest edition).
4. Read and understand all safety signs and warnings.
5. Read and understand the Load Ratings Charts.
6. By understanding the Load Ratings Charts, the operator can determine what the crane can safely lift before attempting the actual lift.
7. The operator must understand crane signals and take signals only from designated signal people. However, the operator must obey the stop signal from anyone.



OPERATOR'S RESPONSIBILITIES

1. Read and understand the Operator's Manual.
2. Make sure the machine is in proper order and that all operational aids and warning signals are functional before operating.
3. Keep the machine clean, including all instrumentation, windows, lights and other glazed surfaces.
4. Remove all oil, grease, mud, ice and snow from walking surfaces.
5. Store all tools, rigging and other necessary items in the tool box.
6. Never lift a load without consulting the Rating Chart Manual located in the operator's cab or control station.
7. Know the load to be lifted.
8. Be alert, physically fit and free from the influences of alcohol, drugs or medications that might affect the operator's eyesight, hearing, or reactions.

(Continued on next page ...)

	OPERATOR'S RESPONSIBILITIES
---	-----------------------------

9. Keep people, equipment and material outside of the work area.
10. Signal person(s) must be used when the operator's vision is blocked or when working in hazardous areas such as near power lines or people.
11. Keep a fully charged fire extinguisher and first aid kit in the operator's cab at all times and be familiar with the use of these items.
12. Always know the location of other machinery, vehicles, personnel and other obstacles in the work area.
13. Never permit people on the machine platform while the machine is in operation.
14. Make sure everyone is clear of the work area before moving the hook, boom, load or outriggers.
15. Start and stop movements smoothly and swing at speeds that will keep the load under control.
16. Keep at least two full wraps of wire rope on drum when operating.
17. Use tag lines to keep loads under control when feasible.
18. Keep the load as close to the ground as possible.
19. Use shortest boom length required to complete job.
20. Never leave a running machine unattended or load suspended.
21. Always use outriggers in accordance with requirements of the Load Rating Chart and Operator's Manuals.

	SIGNAL PERSON'S RESPONSIBILITIES
---	----------------------------------

1. Standard crane signals must be used, and understood.
2. Assist the operator in safe and efficient operation, without endangering people or property.
3. Have a clear understanding of each lift to be made.
4. Signal people must place themselves where they can be clearly seen and where they can safely observe the entire operation and out of harms way should something unexpected happen.



RESPONSIBILITIES OF ALL CREW MEMBERS

1. Unsafe conditions and/or practices must be corrected.
2. Obey all warning signs.
3. Watch out for your safety and the safety of others.
4. Know and understand proper machine erection and rigging procedures.
5. Alert operator and signal person of hazards, such as power lines, unstable ground, etc.



MANAGEMENT RESPONSIBILITIES

1. Operators must be competent, physically fit and, if required, licensed.
2. Operator, signal people and riggers must be trained in correct crane operation and use.
3. Operator and signal people must know standard crane signals.
4. Have a supervisor at job site responsible for site safety.
5. Crew members must be given specific safety responsibilities and be instructed to report any unsafe conditions to supervisor.
6. Supply the weight and the characteristics of all loads to be lifted to the operator.
7. Verify that all crew members are familiar with OSHA, ANSI B30.5 requirements, state and local jobsite requirements, as well as the instructions in manuals, and all other applicable requirements.



PLANNING THE JOB

1. Have a clear understanding of the work to be done.
2. Consider all hazards at the jobsite.
3. Know what crew members are needed to complete the job.
4. Assign job responsibilities.
5. Appoint a competent signalperson.
6. Establish how the signalperson will communicate with the operator.
7. Know the weight and the characteristics of the loads to be lifted.
8. Utilize rigging and other equipment which will complete the job safely.
9. Establish how equipment can be safely transported to the job site.
10. Determine how the load will be rigged.

(Continued on next page ...)

	PLANNING THE JOB
---	-------------------------

11. Determine the lift radius, boom angle and the rated lifting capacity of the crane.
12. Always pre-plan the course of each lift to determine the best route to reach the load's target destination.
13. Identify the location of gas lines, power lines, or other structures and determine if the crane or structures need to be moved.
14. Ensure that the supporting surface is strong enough to support the machine and load.
15. Establish special safety precautions, if necessary.
16. Consider the weather conditions.
17. Keep unnecessary people and equipment away from the work area.
18. Position the machine to use shortest boom and radius possible.

	OPERATOR PRELIFT CHECK
---	-------------------------------

1. Check the machine log book, to see if periodic maintenance and inspections have been performed.
2. Ensure that necessary repairs have been completed.
3. Inspect wire rope for damage (kinks, broken wires etc.)
4. Be sure no unauthorized field modifications have been made.
5. Check for air and hydraulic oil leaks.
6. Check that all controls are in the neutral position before starting engine.
7. After starting the engine, check all gauges and indicators for proper readings.
8. Test all controls in the cab or control station, such as swing, boom extend / retract / up / down, outriggers extend / retract, throttle.
9. Check brakes.
10. Check hoist brakes by lifting a load a few inches off the ground and holding it.

	OPERATOR AIDS CHECK
---	----------------------------

Ensure that the listed items are in place and operational.

1. Boom angle indicator.
2. Backup Alarms.

(Continued on next page ...)



OPERATOR AIDS CHECK

3. ATB devices.
4. Overload Protection, Load Indicators, Rated Capacity Indicator.



OPERATION OVERLOAD PROTECTION

1. Know the weight and characteristics of all loads to be lifted.
2. Place the boom lifting point directly above the load when lifting.
3. The load radius will increase when the load is lifted due to boom deflection. To compensate for the boom deflection, maintain the radius by raising the boom.
4. Know the weight of the hook and rigging, the boom and/or jib length, parts of line and the work area.
5. Use next lower rated capacity when working at boom lengths or radius between the figures on the rated lifting capacity chart.
6. Never lift a load without knowing whether it is within the rated capacity.
7. Never operate with anything other than recommended counterweight. Unauthorized reduction or additions of counterweight constitute a safety hazard.
8. Do not lift loads if winds create a hazard. Lower the boom if necessary. Refer to the Rating Chart and Operator's Manual for possible restrictions.
9. Avoid side loading the boom.
10. Never allow the load or any other object strike the boom.
11. Loads shall be freely suspended.
12. Never use the RCI to "weigh" the load.



OPERATION SETUP

1. Be sure the load bearing surface is strong enough to support the machine with lifted load.
2. Be sure the crane is level. Check frequently and re-level when necessary.
3. Stay away from rotating cranes. Erect barricades to keep people away. Make sure these areas are clear before swinging. **WARNING-INJURY CAN OCCUR!**

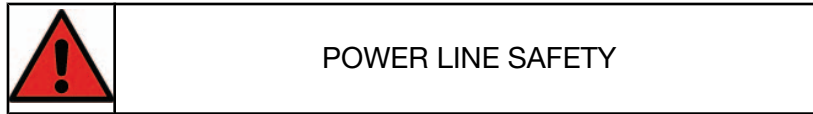

1. Determine whether there are power lines in the area before starting any job. Only operate around power lines in accordance with Federal, State and Local Regulations as well as ASME B30.5 (latest edition).
2. Never remove materials from under powerlines with a crane if the boom or machine is capable of contacting them.
3. No part of the crane or the load should contact, or violate the minimum allowable clearance required for operation of the crane near electrical lines.

(Continued on next page ...)

 POWER LINE SAFETY

 **DANGER**



Electrocution Hazard
Contact with electric power lines will result in death or serious injury.

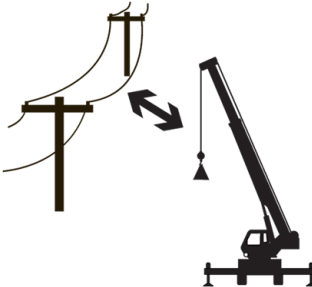

Maintain Clearance Listed	
Line voltage	Required clearance
0 to 50 kv	10 ft (3 m)
>50 to 200 kv	15 ft (4.6 m)
>200 to 350 kv	20 ft (6.1 m)
>350 to 500 kv	25 ft (7.6 m)
>500 to 750 kv	35 ft (10.7 m)
>750 to 1000 kv	45 ft (13.7 m)
>1000 kv	Refer to Operator's Manual

Before operating the machine, contact the electric power line owner to disconnect, move, or insulate power lines.

Electrocution Hazard	
Contact with electric power lines will result in death or serious injury.	
Maintain Required Clearance	
LINE VOLTAGE	REQUIRED CLEARANCE
0 TO 50kV	10 FT (3.0M)
500 TO 200kV	15 FT (4.6m)
2000 TO 350kV	20FT (6.1m)
350 TO 500kV	25FT (7.6m)
500 TO 750kV	35 FT (10.7m)
750 TO 1000kV	45FT (1.37m)
>1000kV	Refer to Item 7
Before operating the machine, contact the electric power line owner to disconnect, move, or insulate power lines.	

(Continued on next page ...)

	POWER LINE SAFETY
---	--------------------------

4. If contact occurs, stay on crane until the boom is cleared or until the electrical current is turned off.
5. If contact occurs, keep all personnel away from the crane. If you must leave the crane, **JUMP WITH BOTH FEET TOGETHER COMPLETELY CLEARING THE MACHINE.** Continue jumping with both feet together to leave the area.
6. Use a signal person when working around power lines as established by the utility owner / operator or registered professional engineer who is a qualified person with respect to electrical power transmission and distribution per OSHA regulation 1926.1408 and 1926.1409.

	TRAVEL
---	---------------

1. Care must be taken when cranes are driven (traveled) whether on or off the job site.
2. Always pre-plan the path of travel to determine the best route to the destination.
3. A signal person shall be utilized when the operator's vision is blocked or obstructed during traveling operations.
4. Watch for people, power lines, low or narrow clearance, bridge or road load limits, steep hills or uneven terrain.
5. Place the boom in the stowed position.
6. Inflate the tires to the specified pressure.
7. Travel slowly and avoid sudden stops and starts.
8. Use the seat belt during all transit and travel.
9. Make sure travel surfaces can support the weight of machine and any stored load.
10. Always set the parking brake when parking the machine.

	OPERATIONAL AIDS - EMERGENCY PROCEDURES
---	--

When operational aids are inoperative or malfunctioning, the following requirements shall apply for continued use or shutdown of the crane.

1. Steps shall be taken to schedule repairs immediately. The operational aids shall be put back into service as soon as replacement parts, if required, are available and the repairs and calibration can be carried out. "Can be carried out" does not mean, when convenient. Every effort must be made to expedite the repairs and recalibration.

(Continued on next page ...)



OPERATIONAL AIDS - EMERGENCY PROCEDURES

2. When a load indicator, rated capacity indicator, or rated capacity limiter is inoperative or malfunctioning, the designated person responsible for supervising the lifting operations shall establish procedures for determining load weights. Loads with unknown weights shall not be lifted without a properly functioning load indicating device.
3. When a boom angle or radius indicator is inoperative or malfunctioning, radii or boom angle shall be determined by measurement.
4. When an ATB device, two-blocking damage prevention or two-block warning device is inoperative or malfunctioning, the designated person responsible for supervising the lifting operations shall establish procedures, such as assigning an additional signal person, to furnish equivalent protection.
5. When a boom length indicator is inoperative or malfunctioning, the designated person responsible for supervising the lifting operations shall establish the boom length at which the lift will be made by actual measurement or marking on the boom.
6. When a level indicator is inoperative or malfunctioning, other means shall be used to level the crane within the level requirements specified by the manufacturer.

In certain situations, it may be necessary to override the automatic motion limiter of the RCI / ATB unit in order to safely operate the crane. These include but are not limited to:

The load block may lift the ATB weight before the load line can be tensioned while stowing the boom. This will cause a motion cutout. Overriding the system, in this situation is acceptable in order to continue to winch in slack line, securing the boom. Boom must be in the lowered position.

Effects of Wind Conditions

Lifting Constraints

The crane can be used safely by following the values given in the load capacity tables up to a wind speed of 27.8 ft/s (30 kph - force 5) on a load surface of 11.7 ft²/ton.

	Check the forecast and monitor wind speed conditions near the job site. When wind speed exceeds 20 mph (32 kph - force 5), derating of the cranes lifting capacity is required.
---	---

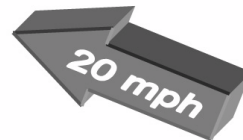
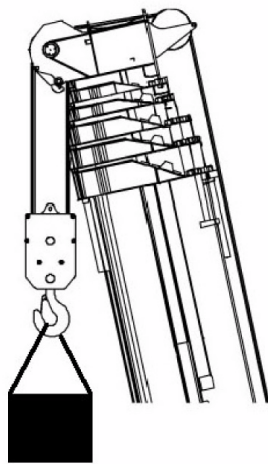

Wind

MAXIMUM OPERATIONAL WIND SPEED BEFORE DERATING OF LIFTING CAPACITY IS REQUIRED.



Pay attention to the wind speed values in table below in relation to the information in the WARNING section of the LOAD CHART. Any governmental regulations applicable to the job site must also be observed.

Wind Force		Wind Speed		Consequences
Scale	Terms Described	mph	kph	Inland Territories
0	Calm	0 - 1	1	Calm, Smoke rises vertically
1	Very Light	1 - 3	1 - 5	Wind direction indicated by the smoke and not by the banner
2	Light Breeze	4 - 7	6 - 11	The wind can be felt on the face, the leaves rustle , the banner moves
3	Gentle Breeze	8 - 12	12 - 19	Leaves and small branches move, banners lift
4	Mild Breeze	12 - 18	20 - 28	The wind raises dust and leaves. Branches move
5	Fair Breeze	18 - 24	29 - 38	Small bushes sway. Wave crests form on the sea.
6	Strong Breeze	24 - 31	39 -49	Large branches sway.
7	Strong Wind	31 - 38	50 - 61	All the trees sway

Lightning Storm

When lightning is striking in the vicinity of the crane, the operator should never attempt the following procedures:

- Getting into the operator's cab or attempting to get onto the carrier, superstructure or boom assembly.
- If on the machine, do not try to get off the machine.

If you are in the operator's cab during an electrical storm, stay in the cab. If you are on the ground during an electrical storm, stay away from the vicinity of the machine.

Temporary Interruption of Crane Operations

As a general rule, if it is not possible to maintain sufficient control over a rigged crane, the boom and the equipment shall be taken down if the crane's operations are interrupted and may be left unsupervised.

The following instructions are valid for every mobile crane, regardless of the type, the configuration, the rigging mode and the environment:

- The crane shall be left in the smallest, most stable, valid operational configuration that the job site practically allows; this includes parameters such as boom angle, slewing orientation, jib angle.
- The engines shall be switched off.
- All control levers shall be put into the neutral or in a “locked” position.
- The heating system should be switched off.
- The crane shall be secured and the cabins shall be locked to prevent unauthorized use or unintended movement.
- Close all control panels that are fitted with a lock/key when they are not in use.
- Depending on the crane type, mobile control panels connected to the crane with cables shall be removed when they are not in use.
- The radio remote control, if it is available, shall be kept in a safe place to prevent unauthorized use or unintended movement. Make sure that the batteries are recharged.
- The parking brake of the crane chassis shall be applied.
- Transmission gear shall be set to neutral.
- The wheels shall be secured with chocks, the slew brake applied and the main boom secured.

If the crane is in erected mode and the jobsite conditions do not permit the boom and jib of a crane to be fully lowered to the ground, the configuration in which the crane should be left while unmanned shall be determined by a qualified crane operator familiar with the crane, the job site configuration, conditions, and limitations. In addition, following instructions shall be observed:

- A suitable and safe emergency plan shall be worked out to allow bringing the crane into a safe position in case of emergency such as an unforeseen weather change or other possible incidents as listed at the beginning of this document. This plan shall also include sufficient space around the crane to enable dismantling or lowering of boom or equipment, etc.
- The crane shall be left with no load on the hook.
- All slings or fastening ropes shall be removed from the crane hook.
- The hook block shall be at the highest position so that there is no contact possible between the wire ropes and the boom or other obstacles.

- The crane location and configuration does not create hazards to the road traffic, e.g. risk of collision with surrounding obstacles; this may require a specific risk assessment prior to leaving the crane unattended.
- Check for leakage and unintended (slow) movement on all load bearing hydraulic cylinders and winches:
 - Outrigger vertical cylinders
 - Boom lifting cylinder(s)
 - Hoist winch
 - Boom extension cylinder(s)



NOTE: *Slight movement can also be due to changing oil temperature (e.g. slight cylinder movement due to sun warming or hydraulic oil cooling).*

- Weather forecast shall be obtained in advance for the whole period the crane is erected.
 - Changing meteorological conditions, including, but not limited to: wind, ice accumulation, precipitation, flooding, lightning, etc., should be considered when determining the location and configuration of a crane when it is to be left unattended.
 - The crane boom should be lowered before wind speeds exceed the permitted values. This may not be possible depending on job site and crane setup.
 - If, due to unforeseen weather conditions, the wind speeds are in excess of the permitted values with the boom in the up position, the crane should be secured as best it can and everyone cleared from the area.
 - The boom may only be lowered if the expected wind speed during the lowering process is less than the wind speed allowed during assembly and disassembly according to the wind speed charts.

Potential hazards from Unattended Crane - Possible Issue/Risk

The following are examples of possible events that could occur while a crane is left unattended; these possible risks shall be taken into account:

- Ground failure:
 - Ground giving way due to severe rain/ landslides/ washout
 - Melting ice under the supports
- Bad weather:
 - Storm and wind
 - Lightning
 - Rain/Flooding
- Crane hydraulic cylinders movement:

Slow retraction of outrigger support cylinders, lift cylinders and/or telescoping cylinders on unpinned telescoping systems (e.g. due to changes in ambient and oil temperature, leakage).

- Vandalism.

Any or a combination of the above may result in the following events:

- The crane may topple over.
- The crane may move.
- Unsafe operational conditions may be created.
- Unauthorized operation of the crane may occur.

Resuming Crane Operations

Before crane operation is resumed after a period of inactivity/crane being unattended, the operator is required to check the condition of the crane and its location.

Whenever the operator has left the cab, the Rated Capacity Limiter (RCL) settings must be verified and reset.

Ending Crane Operations

Prior to leaving the crane, the operator must be certain the crane is in a condition acceptable to be left unattended.

End of Operations checklist

1. _____ Is the load fully on the ground and unhooked from the crane?
2. _____ Is telescopic boom all the way in?
3. _____ Is work-site crane boom all the way down and disassembled if necessary?
4. _____ Is parking brake on crane chassis set?
5. _____ Is crane engine off and ignition key removed?
6. _____ Is the crane cab locked?
7. _____ Is the crane secured from unauthorized use?
8. _____ Is the vehicle cab unoccupied?
9. _____ Is the vehicle engine off and the key removed?
10. _____ Is the vehicle parking brake set?

Turning/Driving in Reverse

While operating a mobile crane in reverse, the risk of accident or injury is greater and extra caution must be exercised.



Risk of accidents and personnel injury or death is increased when operating in reverse.

The following cautions must be observed at all times:

- When backing up, the driver must be aware of the needs of other traffic and their safety.
- If the driver does not have visual access to all the areas into which he will be travelling, a guide, who is in communication with the driver at all times, must be used who can see those areas the driver cannot.
- An acoustical back-up warning device does not replace the need for a guide.
- Be certain that no personnel or objects are behind the vehicle before moving.



Injury or death may occur while driving in reverse.



Property damage may occur while driving in reverse.

- Rated maneuvering speed is the maximum speed allowed while driving in reverse.
- Follow all other regulations pertaining to driving on construction sites or on local streets.

Parking the Vehicle



NOTE: *Parking Instructions only apply to mobile cranes.*



Failure to adequately a secure parked vehicle may result in vehicle roll-off and injury or death to personnel and/or damage to property.



Risk of Death

The following conditions must be strictly adhered to by the crane operator:

- A vehicle should never be parked on a slope greater than 18%.
- The parking brake should always be applied when the crane is parked.
- The ground on which the crane is parked must be even and solid with sufficient load-bearing capacity.



Mobile cranes can roll away, if not properly prepared, causing injury, death or property damage.

Under the following conditions, the vehicle must employ the use of the (4) four wheel chocks on the rear axle, where (2) wheel chocks are on front side of rear tires and (2) wheel chocks are on rear side of rear tires in addition to the parking brake to prevent it from rolling away:

- The vehicle is parked on a slope.
- The vehicle is under repair or in need of repair, especially concerning any deficiencies in the brake system.

Lock Out & Tag Out

Occupational Health & Safety Code of Federal Regulations number 1910.147 requires that employers establish and follow a Lock Out & Tag Out procedure and train their employees in that procedure before any employee can operate, service or maintain any piece of power equipment.

Employers are required to make periodic inspections to see that their Lock Out & Tag Out procedures are being followed, and they must monitor and update their program on an ongoing basis. Employees are responsible for seeing that equipment is locked out and tagged out in accordance with the employer's policy.

A typical Lock Out & Tag Out kit contents are illustrated in the figure below.

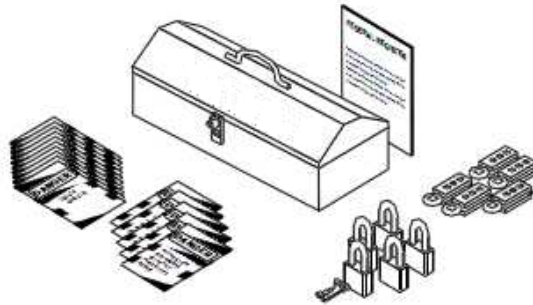

Typical Lock Out & Tag Out Kit

What is Lock Out & Tag Out

Lock Out & Tag Out is a procedure that's designed to prevent the unexpected or accidental startup of equipment and to alert all workers whenever it is unsafe to operate any piece of equipment. When used as intended, Lock Out & Tag Out also protects personnel from energy stored in devices such as springs, accumulators, batteries, hydraulic systems, etc.

How to Lock Out & Tag Out

- Install one or more locks to hold the master switch lever in the **OFF** position.
- If the switch is keyed, turn the key to the **OFF** position and remove the key.
- Disconnect the batteries.
- Regardless of which lockout method is used, place one or more tags on machine control panels, access doors and electrical panels.

When is Lock Out & Tag Out required

- Any time anyone is maintaining, repairing, lubricating, or for whatever reason, working on the equipment.
- When the equipment is broken or for whatever reason, unfit or unsafe to operate
- Whenever the equipment is left unattended.

Who must apply a lock & tag

- Any person working on the equipment.
- Foreman or other person responsible for the work being done.
- If several people are working on a machine at the same time, each person must apply his or her own lock and tag.

When can a lock and tag be removed

After performing these six steps:

1. All safety guards are back in place.
2. All work is complete and tools are put away.
3. All workers are notified that a lock is being removed.
4. All workers are positioned safely for startup.
5. Controls are positioned for safe startup.
6. The machine is ready for safe operation.

Who can remove a lock and tag

- Only the person who applied a lock and tag is permitted to remove them.

The Lock Out & Tag Out rules laid out here are generic. To get instructions for your particular workplace, consult your employer's Lock Out & Tag Out procedure.

Access/Egress



Access/Egress Safety

Access and egress from the crane operator's cab must always be accomplished using a three-point system. Either two-feet and a hand or two hands and a foot should be in contact with the crane while moving from the ground into the operator's cab or moving from the operator's cab to the ground.

To provide safe access and egress to/from the crane, Load King provides a number of steps, ladders and handrails allowing three--point access to all areas of the crane where it is necessary for the operator to be when moving from the ground to the operator's cab or from the operator's cab to the ground.



Access/egress to/from areas of the crane not accessible through the provided three-point access devices should only be attempted using OSHA approved access devices (ladders, lifting platforms, etc) providing three- point access capability.







Personal Safety



SLIP AND FALL PREVENTION

1. Always wait until machine has stopped before getting on and off the equipment.
2. Do not use controls or steering wheel as hand holds.
3. Keep the machine clean and dry. Remove all oil, grease, mud, ice and snow from walking surfaces.
4. Store all tools, rigging and other items in the tool box.
5. Replace all broken ladders or other access system components.
6. Keep non-slip surfaces in good condition.
7. Never jump off the machine. Instead, use the hand holds and step designed for entering and exiting the machine. Face the machine and use three points of contact to ensure your safety.

Seat Belts

SOME SUGGESTED USAGE AND MAINTENANCE INSTRUCTIONS FOR SEAT BELTS

1. Wear your lap belt low and snug.
2. Manually adjustable lap belts and shoulder harnesses are adjusted by pulling the loose end of the webbing through the buckle or adjuster.
3. Seat belts using automatic-locking or emergency-locking retractors are self-adjusting.
4. Hand wash webbing with warm water and mild soap. Rinse thoroughly and dry in the shade.
5. Do not bleach or re-dye, because such processing may severely weaken the assembly.
6. Inspect the seat belt assembly frequently. Anytime it does not operate properly, or if there are any defects in the webbing (e.g. torn or frayed), the seat belt must be replaced.
7. For a non-locking retractor belt, completely extend the lap belt from the retractor(s). After adjusting the belt snugly (see # 2 above), attempt to pull additional webbing from the retractor. If no additional webbing can be pulled from the retractor after adjustment, then the seat belt is adjusted properly.

Wire Rope Reeving

Reeving diagram for the main hoist line are shown. The number of parts of line used will depend on the load to be lifted. Refer to the maximum load chart for the required reeving. Hoisting and lowering speeds will be reduced as the number of parts of line increase.

BOOM CONNECTION FOR EVEN PARTS OF LINE

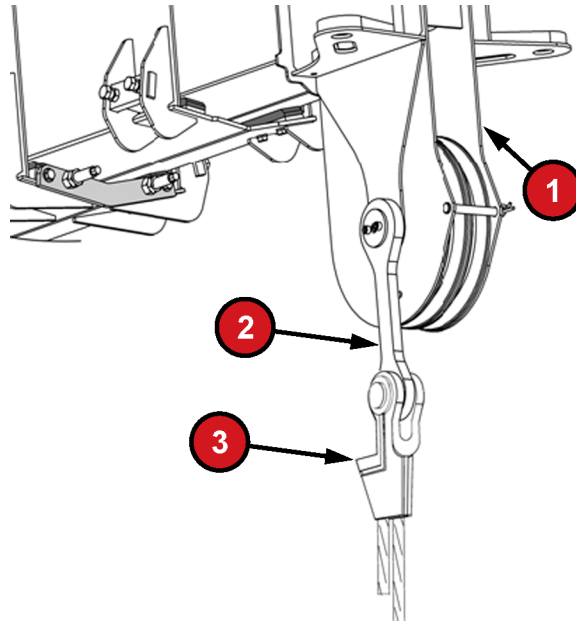

1	Boom Head	3	Dead End Socket
2	Dead End Link		

MULTIPLE PARTS OF LINE EXAMPLES

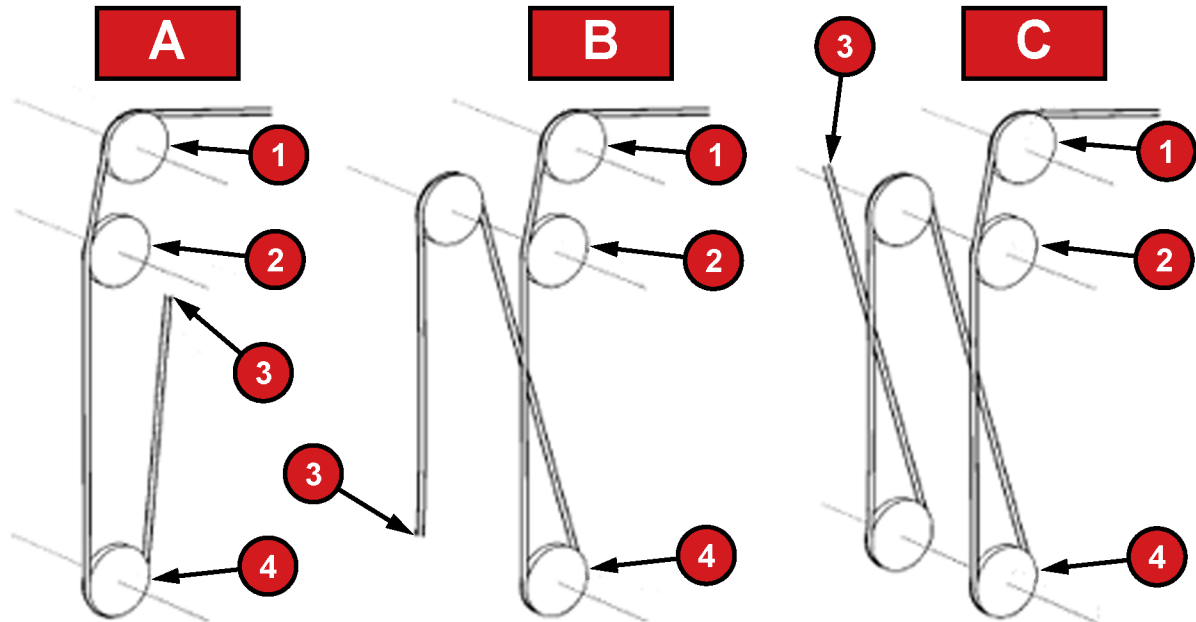

A	2 Parts of Line	2	Boom Point Sheave
B	3 Parts of Line	3	Dead End
C	4 Parts of Line	4	Load Block Sheave
1	Guide Sheave		

Dead Ending Wire Rope in Socket

Below are shown the three different ways to dead end wire rope:



1

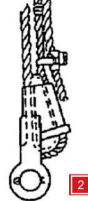

2

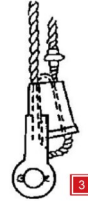

3

1	LOOP BACK METHOD	3	SPECIAL CLIP METHOD
2	EXTRA PIECE SAME SIZE ROPE CLIPPED TO MAIN ROPE METHOD		

Jib Mounting

Some models are equipped with an optional side stow jib. Instructions for installing the jib follow.



DO NOT RIDE OR CLIMB ON BOOM OR JIB. SERIOUS INJURY OR DEATH COULD OCCUR. USE A LADDER OR SUITABLE PLATFORM TO REACH ELEVATED PIN LOCATIONS.

JIB INSTALLATION PROCEDURE

1. Starting with a fully leveled Boom Truck, fully retracted boom, fully extended front and rear outrigger arms and jack cylinders. Rotate the boom to the street side of the boom rest, and lower until boom head can be reached from the ground.

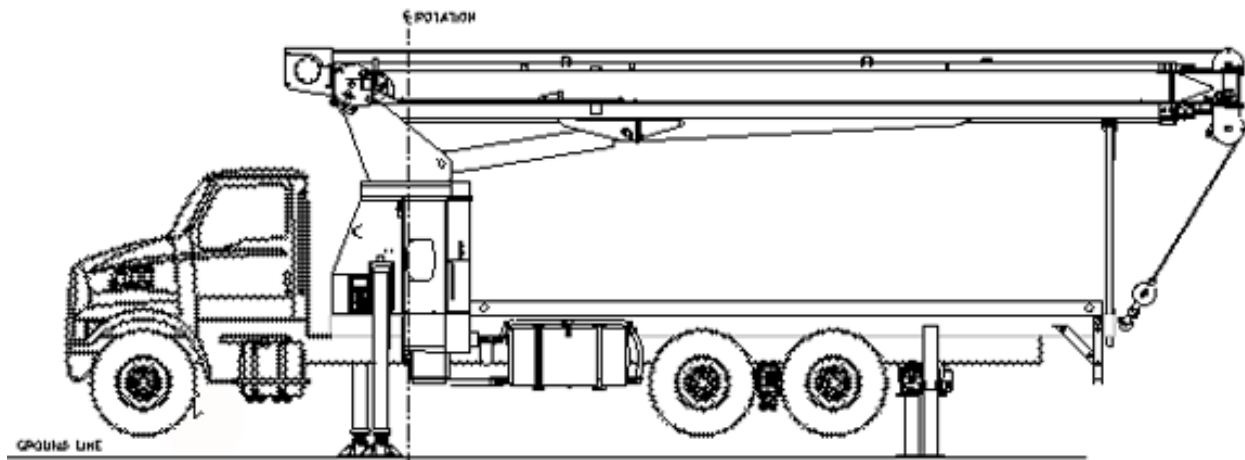

2. Remove the ATB weight and chain clevis from the ATB switch.



3. Remove bottom and top retainers and guide pins from sheave head.



Arrow indicates PIN to be removed.

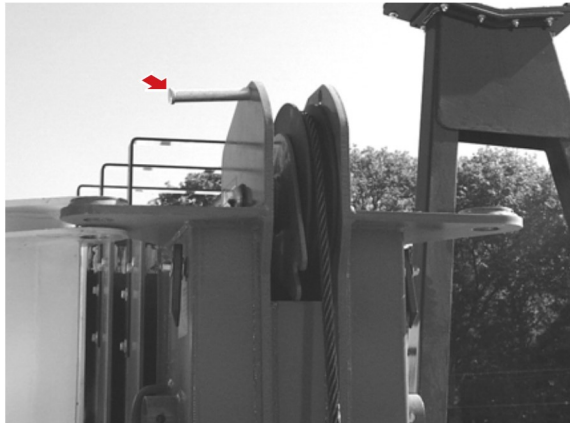

Arrow indicates PIN to be removed.

4. Reinstall top and bottom guide pins and retainers in the sheave head.

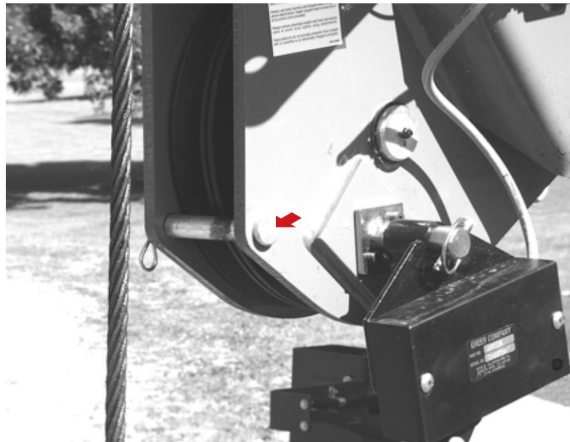

Arrow indicates PIN to be installed.

5. Remove load line from boom head sheave and allow it to hang off the side of the boom.



6. Remove two pins and retainers from outer pin stow bracket.



7. If holes in the jib do not line up with the holes in the boom head, readjust the boom head by slightly extending, then fully retracting the boom. Install two pins and retainers from pin stow bracket, to fasten jib in place on the right side of the boom.

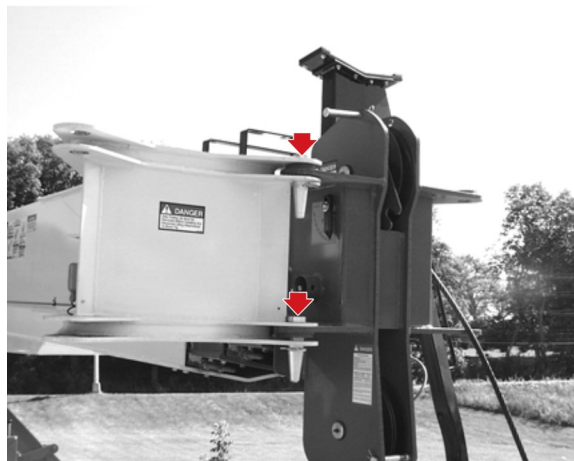



NOTE: *If any force is required to install any of the four jib pins, it should not be more than a few hits from a machine hammer.*

8. Raise boom to horizontal position.



JIB WILL SWING UNCONTROLLED IF BOOM IS NOT HORIZONTAL. THERE IS A DANGER OF BODILY HARM IF THE JIB IS NOT PROPERLY CONTROLLED.

9. Fasten a tag line, approximately 15 feet long, to the anchor point at the end of the jib.

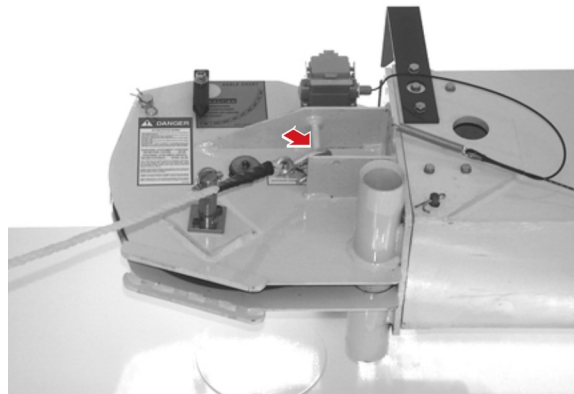

10. **DO NOT REMOVE PIN SECURING JIB TO THE BOOM, AT JIB STOW BRACKET UNTIL STEP 7 HAS BEEN PERFORMED, OTHERWISE JIB WILL FALL OFF THE BOOM CAUSING SERIOUS INJURY TO PERSONNEL AND PROPERTY DAMAGE.**



Arrow shows location of jib pin in stow bracket.

Confirm jib is pinned to boom head and then remove pin from jib pin stow bracket on boom. **Do not remove pins until Step 7 has been completed.**

11. Extend the boom approximately 15 inches so the jib stow bar is clear of the front jib stow bracket at the boom head.



Arrow indicates location of Stow Bracket.

12. Swing jib away from boom with tag line. Control movement of the jib at all times to prevent injury and/or equipment damage.



13. Swing jib into extended position. If it is difficult to bring the jib around you may slightly lower the boom angle and re-attempt.



CONTROL MOVEMENT OF THE JIB

14. Due to the weight of the jib, most times it is difficult to get the top pin of the jib to the boom head installed. Proceed with installing the lower curb side pin and retainer of the jib to boom head. Retract the rear outrigger jack cylinders while the front outrigger arms remain fully extended. Lower the boom so the jib head sheave can make contact with a wood block on the ground surface. This will require the boom to be extended to reach ground level.



NOTE: Avoid allowing the jib tip to come in contact with soft surfaces (i.e. dirt, sand or gravel) as material can become wedged between jib tip sheave and side plates.

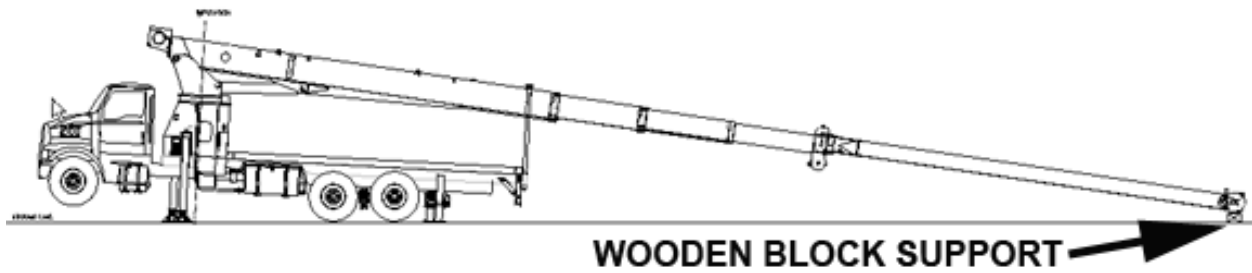

15. Downward pressure can then be applied to the jib sheave head to facilitate top curb side pin alignment and installation by the boom down function.

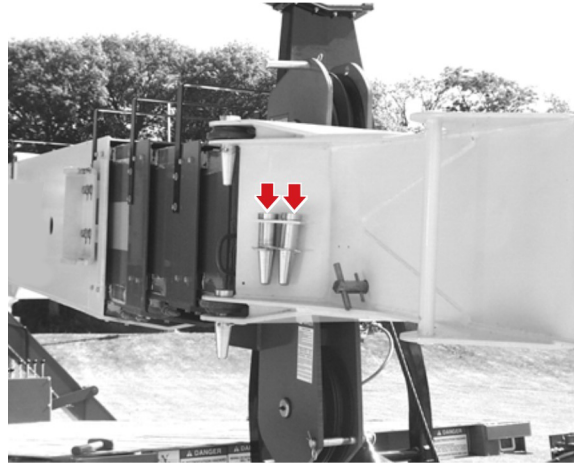

NOTE: *If any force is required to install any of the four jib pins, it should not be more than a few hits from a machine hammer.*



IF THE SECOND STAGE OF THE JIB IS NOT GOING TO BE USED, SKIP TO STEP 24.

EXTENDING SECOND JIB STAGE

1. Unstow ATB cable from jib base section.

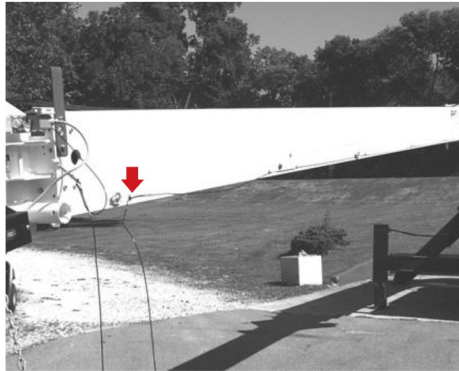

2. Remove ATB switch, retaining pin, and plug from the boom head. Reinstall on jib head.

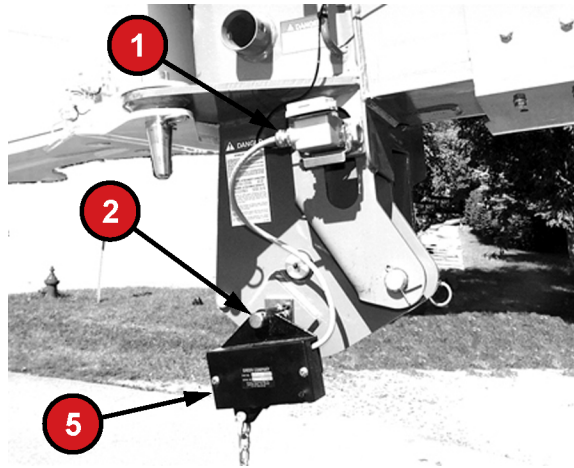

1	PLUG	3	SWITCH
2	RETAINING PIN		

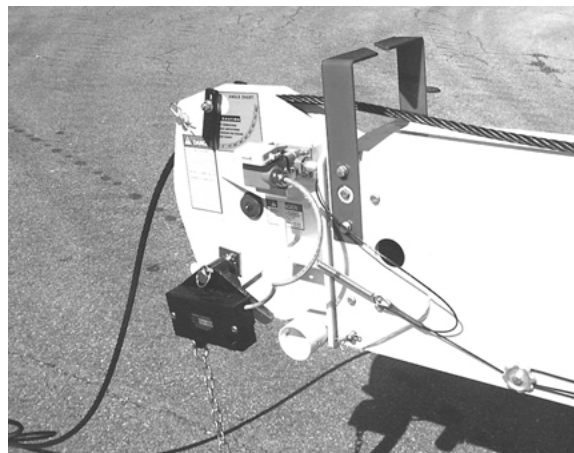

3. Remove ATB from base of jib and install in open receptacle on boom head.

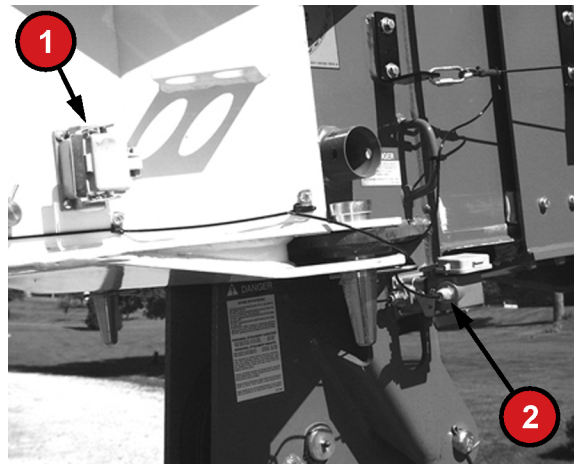

1	JIB BASE RECEPTACLE	2	PLUG
---	---------------------	---	------

4. Raise boom to angle high enough to allow the jib to be extended without contacting the ground.
5. Fasten a tag line to the anchor point on the jib head.



6. Remove lock pin and retainer from rear of jib.



7. Pull second stage jib out until it contacts jib stop pin.



8. Insert jib lock pin into extend position and secure with retaining pin. Push back on second stage to ensure lock pin is securing second stage.

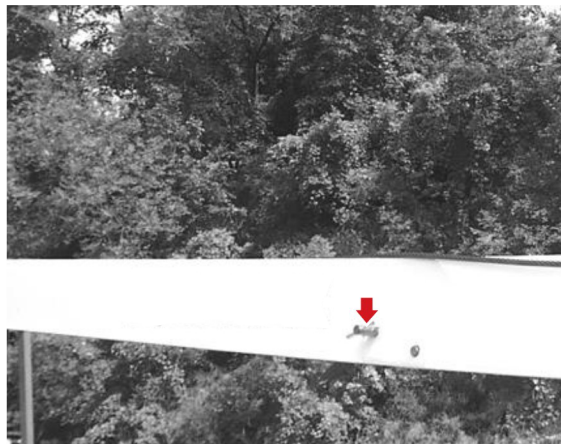

9. Remove ball or block from wire rope.



10. Winch out enough cable to reach over the sheave of the jib.
11. Place wire rope over boom head sheave. If machine is equipped with a sheave retaining bracket, make sure the bracket slot is aligned with guide pin so it is held upright. Install guide pin and retainer.



12. Route cable through jib cable retainer and over jib sheave. Install sheave pin and retainer.

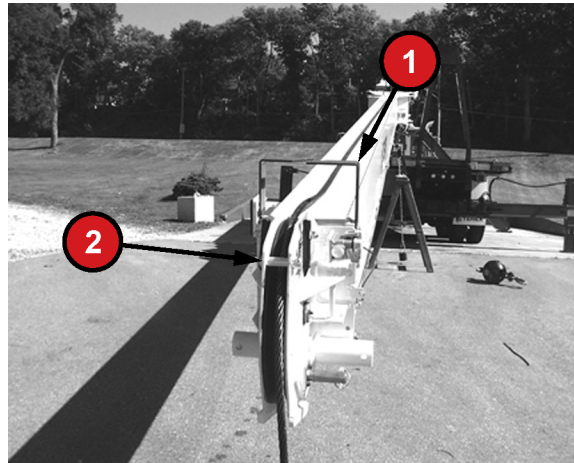

1	CABLE RETAINER	2	PIN
---	----------------	---	-----

13. Attach ball or block to wire rope with pin and retainer.



Page Intentionally Blank

Power Take-Off



Disengage PTO before driving truck. Failure to do so will cause damage to the transmission and hydraulic pump.

There are several styles of PTOs used on various equipment. Refer to the following pages" for operation of the PTO.

Transmission Mounted, Shiftable PTO's

To Engage PTO

1. Set parking brake.
2. Shift transmission to neutral (engage clutch prior to shifting for manual transmissions).
3. Engage PTO by "Pulling Out" knob on dash or by engaging PTO switch.



4. There may be an indicator light on the dash depending on truck chassis model that will illuminate when the PTO is engaged.

To Disengage PTO

1. Store boom in boom rack.
2. Store outriggers.
3. Disengage PTO by "Pushing In" the knob on dash or by disengaging PTO switch.
4. Indicator light on the dash (if available) will go out when PTO is disengaged.
5. If necessary, shift transmission into gear (engage clutch prior to shifting for manual transmissions).
6. Release parking brake (if necessary).

&!- &A Description Of Machine and Controls

Controls

With the dual operator control stations the Load King Stinger can be operated from either side of the unit. The controls on the console are: Boom Swing, Telescope, Hoist and Boom Raise. Engine Start/Stop, Outrigger System and Signal Device. All controls and direction of actuation for desired movement are identified by the information placards mounted on top of the control console or control knobs.

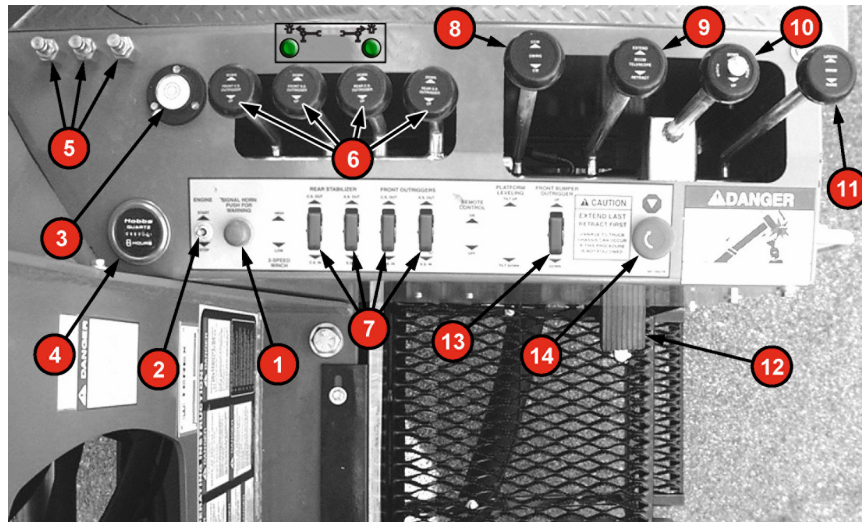

NOTE: Machine has dual control stations. Controls shown are right side. Left side controls are identical. (Except test ports)

1	SIGNAL DEVICE	8	SWING
2	ENGINE START/STOP SWITCH	9	BOOM TELESCOPE
3	LEVEL	10	WINCH (COMBINED FLOW 2-SPEED)
4	HOUR METER	11	BOOM HOIST
5	HYDRAULIC TEST PRESSURE PORTS	12	ACCELERATOR
6	OUTRIGGER EXTEND	13	FRONT BUMPER OUTRIGGER
7	OUTRIGGER JACK	14	EMERGENCY STOP

Outrigger Stow Pins



THE CRANE'S OUT & DOWN OUTRIGGER HORIZONTAL BEAMS ARE EQUIPPED WITH A MANUAL STOW LATCH PIN.

Engage pin at end of each beam before roading unit to prevent inadvertent horizontal movement.

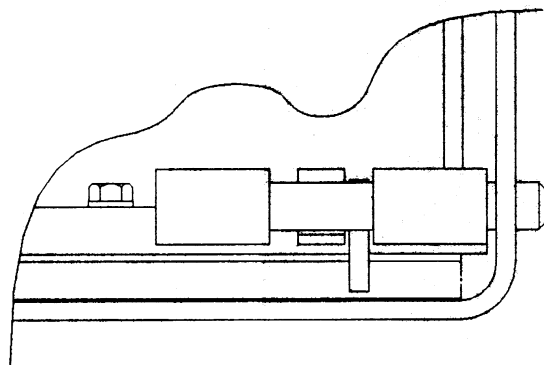

ENGAGED

Disengage pin at end of each beam before extending. Damage to pin and horizontal beam housing may occur if beams are extended without first releasing the stow pin.

&!- &A
Description Of Machine and Controls

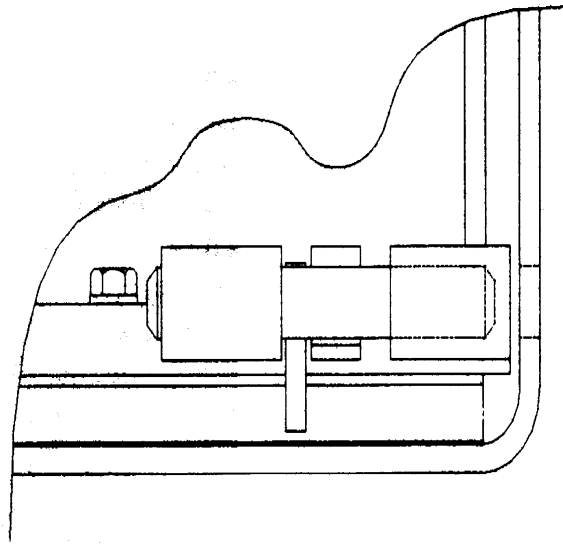

DISENGAGED

Outrigger Controls



ALL THE OUTRIGGERS ON THIS UNIT CAN BE OPERATED FROM EITHER SET OF DUAL CONTROLS. DO NOT OPERATE OUTRIGGERS WITHOUT DETERMINING CLEARANCE FROM OBSTRUCTIONS OR PERSONNEL.

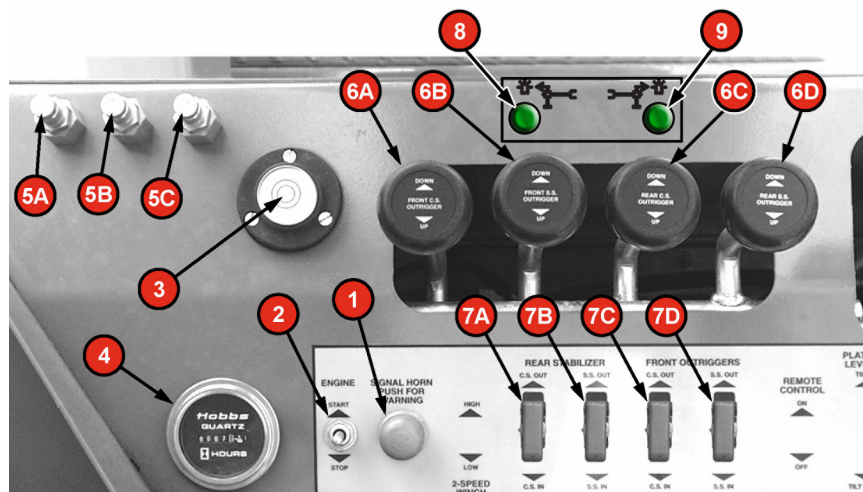

1. SIGNAL DEVICE - Push button to sound truck horn as an audible signal to warn other personnel in the area.
2. START/STOP SWITCH - Toggle up to start engine, toggle down to stop engine.
3. LEVEL - Use outriggers to make sure bubble is centered and machine is level prior to making a lift.
4. HOURMETER - Indicates machine hours.
5. HYDRAULIC TEST PRESSURE PORTS - Attach portable pressure gauge to test relief settings.
 - A. SWING TEST PRESSURE PORT
 - B. WINCH TEST PRESSURE PORT
 - C. BOOM TEST PRESSURE PORT
6. OUTRIGGER EXTEND CONTROLS - Push handle forward to lower, pull handle back to raise.
 - A. FRONT CURB SIDE
 - B. FRONT STREET SIDE
 - C. REAR CURB SIDE
 - D. REAR STREET SIDE
7. OUTRIGGER JACK CONTROLS - Raise cover, push switch forward to extend outrigger, pull switch back to retract.
 - A. FRONT CURB SIDE

&!- &A **Description Of Machine and Controls**

- B. FRONT STREET SIDE
 - C. REAR CURB SIDE
 - D. REAR STREET SIDE
8. OUTRIGGER FULLY EXTENDED INDICATOR LIGHT - Indicator light will turn "GREEN" when streetside outrigger beam is fully extended.
 9. OUTRIGGER FULLY EXTENDED INDICATOR LIGHT - Indicator light will turn "GREEN" when curbside outrigger beam is fully extended.



NOTE: *Always extend outrigger completely before lowering.*



THE CRANE'S OUT & DOWN OUTRIGGER HORIZONTAL BEAMS ARE
EQUIPPED WITH A MANUAL STOW LATCH PIN.

Boom and Winch Controls

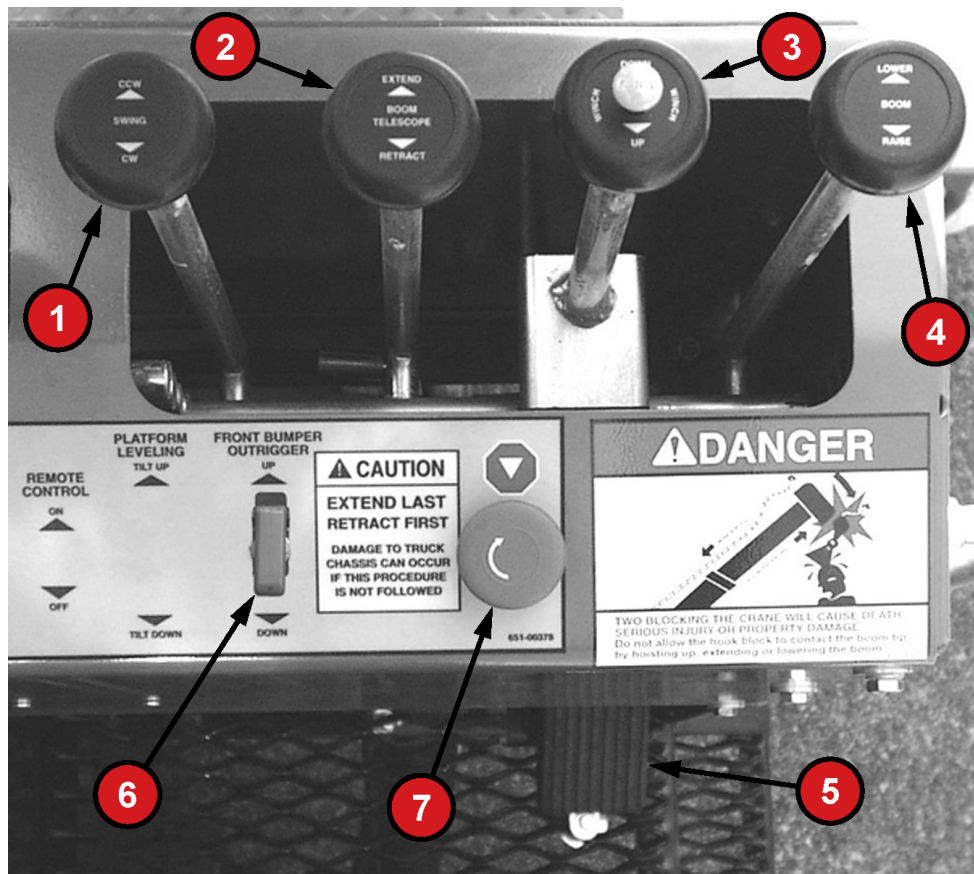

1. SWING - Push lever to rotate boom counterclockwise, pull lever to rotate boom clockwise.
2. BOOM TELESCOPE - Push lever to extend boom, pull to retract boom.
3. WINCH (COMBINED FLOW 2-SPEED) - Push lever to lower loadline, pull lever to raise loadline.

For high speed winching, depress button on control knob while actuating control lever. Release button to return to normal speed winching.

 Frequent use of combined flow 2-speed winch will cause hydraulic oil to overheat. Functions may stop and hydraulic components may be damaged.



NOTE: Controls must be used together to achieve combinations of movements. For instance, the boom extension and loadline (hoist) must be used together to maintain clearance between boom tip and downhaul weight.

4. BOOM HOIST- Push lever to lower boom, pull lever to raise boom.
5. ACCELERATOR - Foot operated with factory adjusted stop for maximum pump speed of 2,000 to 2,200 R.P.M.

&!- &A Description Of Machine and Controls

6. FRONT BUMPER OUTRIGGER- Raise cover, push switch forward to extend outrigger, pull switch back to retract.
7. EMERGENCY STOP - Push to stop engine in case of emergency. Rotate clockwise to release button to allow machine to be started again.

Front Stabilizer

Front stabilizer must be used when working off the front of the truck crane. This outrigger is only used with the continuous rotation option.



Page Intentionally Blank

Rated Capacity Indicator and ATB

Rated Capacity Indicator System

The Load King Boom Truck is equipped with the Greer MicroGuard Rated Capacity Indicator System. The operator is provided with a continuous readout of rated capacity, approach to overload, and two-block condition. Refer to the Greer Operation and setup manual, located in back of this manual, for proper maintenance and setup of unit.



The Greer Insight is designed as an aid. Refer to Maximum Load chart for proper areas of operation.

&!- &A **Description Of Machine and Controls**

ATB Components

CABLE REEL

The ATB cable is wound onto a spring loaded cable reel which is bolted to the left side of the boom base. The reel allows the cable to pay-out and pay-in as the length of the boom is changed. The cable reel has slip rings which allow electric current to flow even while the reel is turning. This cable and reel assembly is also used to measure boom extension when the Boom Truck is fitted with a loadmoment sensing/indicating system.

SHEAVE ASSEMBLIES

The sheave assemblies are installed on the side of the boom and, if equipped, on the side of the jib. The sheaves should be checked periodically to make sure they are free turning and smooth. Rough or sticking sheaves should be replaced as they could damage the ATB cable.

LIMIT SWITCH

An ATB switch is mounted on the left side of the boom tip. The switch is normally open. During operation the switch is held closed by a counterweight suspended from the switch lever by a chain. The closed limit switch allows current to close the relay in the junction box in the pedestal. When the load block (or downhaul weight) is lifted too high, it will lift the counterweight. This action will cause the limit switch to open, breaking the circuit to the relay. This, in turn, de-energizes the coil on the unloader block assembly.

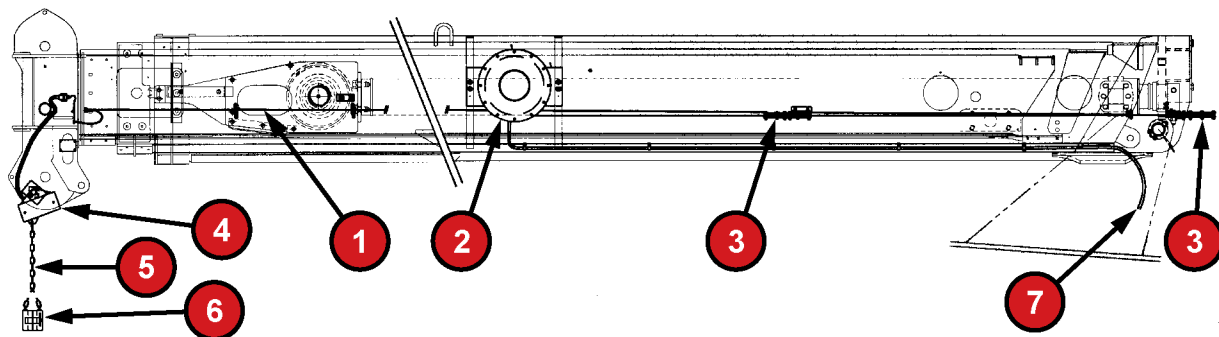

1	2-Block Wire	5	2-Block Chain
2	2-Block Reel	6	2-Block Weight
3	Sheave Assembly	7	2-Block Wire Going to Electrical Box
4	2-Block Switch		

UNLOADER PARTS GROUP

The unloader valve solenoid manifold is located on top of the console assembly, under the swing drive cover. The valve contains two electrically operated solenoids which operate to either contain or unload a pilot signal. (Note: One solenoid is exclusively for the 2-speed winch.) When the solenoid is energized, it is closed and no oil is permitted to pass through the valve. There are three check cartridges in the top of the valve to prevent interfeed

between the other functions incorporated into the block (boom extend, winch up, and boom down.) The 2-speed winch solenoid is also isolated to prevent interference with the boom functions.

The function of “unloading” oil is done by a pilot operated cartridge referred to as a ported anti-void. The anti-void valves are located on the boom and winch control valves. The anti-void separates the work oil from the tank passage in the boom control valve. By adding an orifice in the anti-void, it becomes pressure balanced. When the solenoid on the ATB unloader is opened, oil starts to flow across the orifice in the anti-void and the oil can get out faster than it can get in. This creates a pressure drop and allows the anti-void to open, routing the function oil to tank. See this page for the console components location chart.

&!- &A
Description Of Machine and Controls

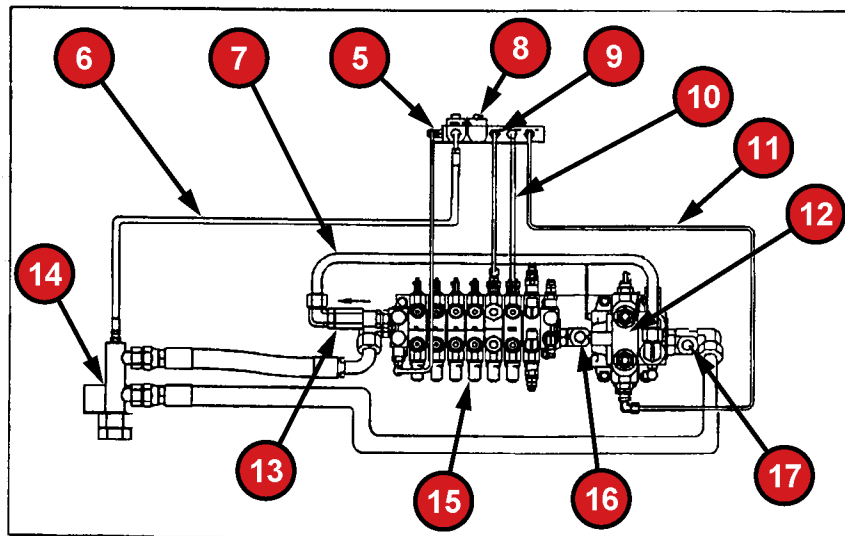
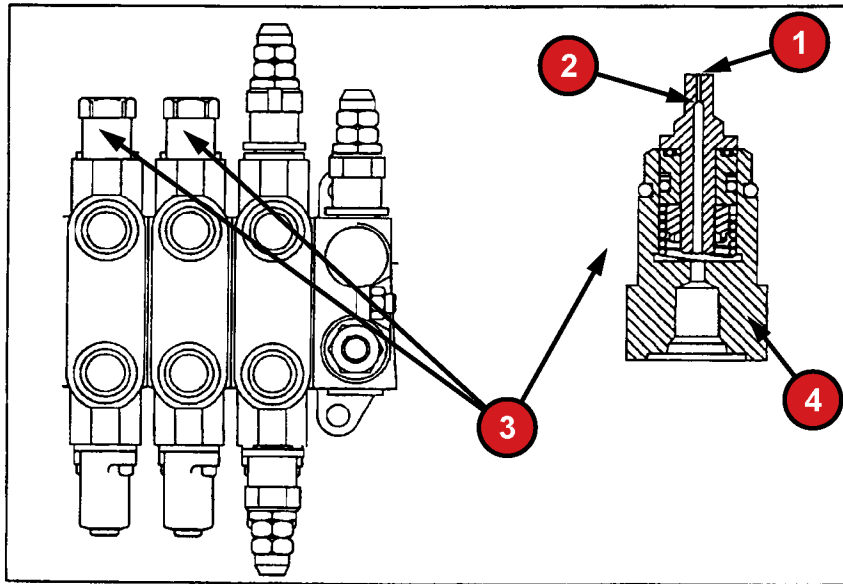

Boom Control Valve

1	Orifice	10	Topping Pilot Line
2	Piston	11	Winch Pilot Line
3	Typical Anti-Void	12	Winch Valve
4	Body	13	One-Way Check
5	Winch Unloader Valve	14	Return Manifold
6	Unloader Tank Line	15	Boom Control Valve
7	2-Speed Winch Regenerative Line	16	Boom Inlet
8	ATB Unloader Valve	17	Winch Inlet
9	Extension Pilot Line		

Pre-Start Inspection

The following items should be checked each day before start-up and the start of operations.

ENGINE OIL

The level should be at the full mark.

COOLANT

The level should be near the bottom of fill neck in coolant tank when cold.

DIESEL EXHAUST FLUID

Check diesel exhaust fluid (DEF) or Urea tank level is full. An illuminated Warning on dash or Check Engine light will indicate a low level. (Tier 4 engine models only)

LEAKAGE

Make a ground check below the machine for signs of leaks. See Hydraulic Hose topic in Maintenance section.

FUEL

Fuel for the engine and for upper unit heater should be adequate for sustained operations.

LUBRICATION

Perform the daily lubrication as required in the Lubrication Recommendations. Lubricate cylinder mounting bushings, and pins.

LINES AND BLOCKS

Inspect the hoist lines, hoist block and ball hook, and the crane attachment in general for readiness.

SAFETY EQUIPMENT

Check the safety equipment, including all lights, brakes, and hazard warning devices.

TIRES

The tires should be checked for proper pressure before traveling the machine. The tires should only be checked when cold. Refer to the Tire Pressure Chart in the operator's cab.

WHEEL NUTS

Torque all lug nuts per supplied chassis manual specifications. Check tightness daily during the first 50 miles of service on new units and any time the wheels have been removed.

GENERAL CONDITION

Inspect the machine in general for wear, leakage, and damage.

AIR TANKS

Open the air tank drain cocks to blow out moisture and sediment.

FUEL FILTER

Water and sediment should be drained from the fuel filter by opening the drain cock at the bottom of each.

ATB SYSTEM

Inspect all ATB switches found on boom, jib, and auxiliary sheave heads for damage. Check the freedom of counterweight attached to these switches; and also, that counterweight is attached around correct line of hoisting cable in the proper manner. Inspect all electrical connections and wires as well as the entire length of cable attached to the cable reel and it's connections for evidence of excessive wear, damage, or improper installation. Check spring loaded cable reel for proper tension and to insure that reel is free to rotate. Verify visual and audible warning devices by lifting each of the counter weights.

This crane is equipped with a disconnect system on the control linkages. A check of this system should be made prior to lifting. Hoist the hook block to the boom point so that actual contact between block and ATB counterweight is made. If all functions are operating properly, winch hoisting will cease and the boom cannot be extended or lowered. Should any of these functions continue, disconnect system is functioning improperly and a complete system check must be made. Boom raise, boom retract, and winch down-functions remain active and will be unaffected by ATB system.



When performing disconnect test, care should be taken as damage may result if disconnect system malfunctions and the hook block is drawn into the boom point.

PUMP DISCONNECT

See Power Take-Off topic in Description of Machine and Controls section of the manual.

Suggested Hydraulic Crane Inspection Checklist

This check list is to be used in addition to the information provided in this manual to properly operate and maintain the machine.

ITEMS TO BE INSPECTED & CHECKED	INSPECTION CODE	SATISFACTORY	ADJUST	REPAIR
* VISUAL INSPECTION (Complete Machine)	D			
* Inspect OVERALL machine (including carrier) for cracks, weld separation, leaks, damage, and vandalism.				
HYDRAULIC SYSTEM (**Leaks or Damage)	D, A			
**See Hydraulic Hose topic in Maintenance section				
OVERALL CLEANLINESS	D			
AIR SYSTEM (Leaks or Damage)	D			
HYDRAULIC FLUID	D			
TRANSMISSION FLUID LEVEL	D			
ENGINE CRANKCASE FLUID LEVEL	D			
FUEL TANK FLUID LEVEL	D			
RADIATOR FLUID LEVEL	D			

**&!- &A
Inspection**

ITEMS TO BE INSPECTED & CHECKED	INSPECTION CODE	SATISFACTORY	ADJUST	REPAIR
MACHINE LUBRICATION	D			
ATTACHMENT PIN BOLTS	D			
MUFFLER/ EXHAUST SYSTEM	D			
ALL CONTROL MECHANISMS	D			
INSTRUMENT GAUGES	D			
CLUTCHES & BRAKES	D			
WIRE ROPE, SHEAVES & GUARDS	D			
TWO BLOCK DAMAGE PREVENTION SYSTEM	D			
LOAD SUPPORTING COMPONENTS CONDITION	D			
FIRE EXTINGUISHER	D			
BACKUP ALARM	D			
BOOM ANGLE INDICATOR	D			
HEAD/TAIL/ BRAKE LIGHTS & 4 - WAY FLASHERS	D			

ITEMS TO BE INSPECTED & CHECKED	INSPECTION CODE	SATISFACTORY	ADJUST	REPAIR
HORN	D			
PROPER CABLE SPOOLING	D			
WEDGE SOCKETS	D			
AXLE FLUID LEVEL	W			
SWING REDUCER FLUID LEVEL	W			
DRIVE SHAFTS & U JOINTS	W			
TIRE & WHEEL CONDITION & INFLATION PRESSURE	W			
AIR REGULATORS	W			
AIR CLEANER ELEMENT	W			
CLUTCH & BRAKE LINKAGE & PINS	W			
WHEEL LUG NUT TORQUE	W			

&! - &A Inspection

ITEMS TO BE INSPECTED & CHECKED	INSPECTION CODE	SATISFACTORY	ADJUST	REPAIR
FAN BELT TENSION	W			
STRUCTURAL MEMBERS & WELDS	W			
BOOM INSPECTION	W			
BATTERIES & STARTING SYSTEM	M			
TRANSMISSION FILTER	P			
ENGINE OIL FILTER	P			
ENGINE FUEL FILTER	P			
SWING BEARING BOLT TORQUE	P			
MACHINERY GUARDS	P			
LOAD CHART & SAFETY WARNINGS	P			
INSPECTION CODE INTERVALS	D - DAILY W - WEEKLY M - MONTHLY A - ANNUALLY P - PERIODIC			



NOTES:

1. Indicate inspection result by checking in the satisfactory, adjust, or repair boxes provided.
2. When appropriate, enter your diagnosis on back of page for repairs or adjustments made.

Daily Check (8 Hours)

- Perform Daily Lubrication
- Check Hydraulic Reservoir Fluid Level
- Fill Fuel Tank
- Check Engine Oil Level
- Check Coolant Level
- DEF Aftertreatment Fluid (Urea) Tank Level (Tier 4 engines only)
- Check Hydraulic Cylinder Mounting Bushings And Pins
- Check Hydraulic Components including hoses. (See the Hydraulic Hose topic in Maintenance section of this manual).
- Check Transmission Oil Level
- Drain Fuel Filters or Water Separator
- Check Boom Front Slider Pads
- Check Boom Chains And Ends
- Drain Air Tanks
- Check Wire Rope And Related Components
- Check Air Cleaner
- Check Controls
- Check Instruments, Gauges, Lights, & Safety Equipment
- Make Overall Visual Inspection
- Check ATB System
- Check Engine Manufacturer's Manual For Additional Maintenance Requirements
- Ensure Swing Brake Is Able To Hold Against Full Torque Of Swing Motor

Weekly Check (40 Hours)

- Perform The Daily Check
- Perform Weekly Lubrication
- Check Swing Reducer Oil Level
- Check Axle Oil Level (after initial change)
- Check Battery Condition
- Check Tire Pressure And Condition
- Check Air System Safety Valve
- Check Torque On Wheel Lug Nuts
- Check Hydraulic Cylinders And Rods
- Make Thorough Inspection Of Wire Rope
- Visually Inspect All Structural Members And Welds For Cracks, Alignment and Wear
- Check Boom For Wear Cracked Welds, Alignment And Missing Or Illegible Decals
- Check Engine Manufacturer's Manual For Additional Maintenance Requirements
- Clean Machine Weekly If Salt Covered To Prevent Rust And Corrosion

Monthly Check (80 hours)

- Perform Daily And Weekly Checks
- Perform Monthly Lubrication
- Check Engine Belts
- Check Hydraulic Reservoir For Moisture
- Check All Slider Pads
- Have Hydraulic Oil Sample Analyzed
- Clean Radiator & Oil Cooler Exterior
- Check Engine Manufacturer's Manual For Additional Maintenance Requirements

Quarterly Checks (250 Hours)

- Perform Daily, Weekly And Monthly Checks
- Perform Quarterly Lubrication
- Drain Fuel Tank Of Water And Sediment If Necessary
- Check Brake Shoes for Wear Condition
- Change Transmission Oil And Shift Air Filter
- Change Hydraulic Return Line Filters
- Replenish Cooling System Corrosion Inhibitor (refer to engine manufactures manual)
- Check Engine Manufacturer's Manual For Additional Maintenance Requirements
- Lubricate Valve Disconnects
- Clean And Wax All Exterior Painted Surfaces

Semiannual Checks (1000 Hours)

- Perform Daily, Weekly, Monthly And Quarterly Checks
- Perform Semiannual Lubrication
- Clean Crankcase Breather
- Check Hydraulic Reservoir Relief Valve
- Clean Hydraulic Reservoir Intake Suction Filter
- Check Air Dryer Desiccant For Signs Of Oil Accumulation
- Change Power Steering Filter Element
- Check Hydraulic Relief Valve Pressure Settings
- Torque Swing Bearing Bolts
- Check Engine Manufacturer's Manual For Additional Maintenance Requirements
- Check all adjustments specified in the "Service / Parts" section of this manual and any vendor manuals supplied

Annual Check (1500 - 2000 Hours)

- Perform Daily, Weekly, Monthly, Quarterly and Semiannual Checks
- Perform Annual Lubrication
- Disassemble Winch And Inspect
- Drain And Clean Hydraulic Reservoir
- Change Hydraulic Fluid (unless checked by oil analysis).
- Drain and Refill The Winch Lubricant
- Change Axle Oil
- Check the hose lines (see Hydraulic Hose topic in the Maintenance section of this manual).

Crane Boom

MAIN BOOM INSPECTION & MAINTENANCE PROCEDURE

Task	Action
<ul style="list-style-type: none"> Broken wire rope or cut strands 	Replace
<ul style="list-style-type: none"> Corrosion of wire rope 	Replace
<ul style="list-style-type: none"> Wire rope kinking, crushing, un-stranding, bird caging, main strand displacement or core protrusion 	Replace
DAILY	
<ul style="list-style-type: none"> Check the sheaves for wear 	
<ul style="list-style-type: none"> Check pins for cracks 	
<ul style="list-style-type: none"> Lubricate the wire ropes 	
<ul style="list-style-type: none"> Clean the wire ropes 	
EVERY 50 HOURS	
<ul style="list-style-type: none"> Lubricate the hook block 	
EVERY 250 HOURS	
<ul style="list-style-type: none"> Lubricate the slides 	
<ul style="list-style-type: none"> Lubricate the main boom head 	
<ul style="list-style-type: none"> Lubricate sliding surfaces 	
EVERY 1000 HOURS	
<ul style="list-style-type: none"> Check the sheaves roller bearings or bushings and are properly lubricated. 	
EVERY 1500 HOURS	
<ul style="list-style-type: none"> Check wear pads, shims & wear pad fasteners. 	Replace as req'd
<ul style="list-style-type: none"> Check chains for adequate lubrication 	
<ul style="list-style-type: none"> Check for corrosion of fasteners 	
EVERY 4 YEARS	
<ul style="list-style-type: none"> Visually inspect extension & retraction ropes. 	Disassemble Boom ¹
<ul style="list-style-type: none"> Check chains for wear 	Disassemble Boom ¹
<ul style="list-style-type: none"> Check cable anchors for corrosion or cracking 	Disassemble Boom ¹
<ul style="list-style-type: none"> Clean boom sections and remove internal grease and re-grease with specified lubricant 	Disassemble Boom ¹
<ul style="list-style-type: none"> Sheave pins check for corrosion and wear 	Disassemble Boom ¹



NOTE: The disassembly of boom is a recommendation for proper inspection related to wear, corrosion, cracks or breakage of components. If crane is used in a highly corrosive environment due to salts or chemicals, then inspection and maintenance intervals should be more frequent than shown above.

WEEKLY:

STRUCTURAL MEMBERS AND WELDS Visually inspect all structural members and welds including (but not limited to) the extended boom for straightness, roller (or pad) adjustment, and cracks. Pay special attention to the longitudinal welds joining the top, side and bottom plates. Check the welds attaching the jib ears to the boom head and the welds attaching the boom head to the tip section. Inspect the cylinder attaching supports and the boom pivot area.

Inspect the superstructure welds, the welds on the hoist cylinder supports and the welds between the bottom mounting plate and the vertical plates. This is especially important if the machine is being used extensively in clamshell, concrete pouring, headache ball, or other high duty cycle applications.

On the carrier, inspect the swing bearing weld band and supporting header welds. Check the welds attaching the outrigger box to the frame, outrigger box ends at the collar, jack cylinder mounting tube, and the beam welds.

Visually inspect all boom sections at least weekly or every fifty (50) hours, whichever occurs first. Preparatory to making the inspection, set the outriggers and rotate the upper to an area where the boom can be fully lowered and extended.

With the boom fully lowered and extended, visually inspect the sides, top and bottom of each section for any unusual deformation, scrubbing, wear, or cracking in either the plates or welds, particularly the fillet welds along the bottom edge of the side plates of the telescoping sections. In addition, note any missing or illegible indicator mark decals on the telescoping sections.



If any cracks in either fillet welds or plates are noted, the particular component must be replaced or repaired before any further crane operations are performed. This is necessary to maintain the structural strength of the boom and prevent possible catastrophic failure resulting in injury or property damage.

If a crack or deformity is discovered, Contact Load King Manufacturing Service Department for instructions. Field repairs should only be preformed with approval of Load King Service and Engineering.

If a crack or deformity is discovered, Contact Load King Manufacturing Service Department for instructions.



NOTE: Field repairs should only be preformed with approval of Load King Service and Engineering.

Boom extension indicator decals are extremely important and must be in place at all times." Boom section failures can occur due to overstressing within rated capacities if the sections" are not equally extended within one indicator mark difference between the telescoping" sections.

&!- &A Inspection

If any indicator decals are missing or illegible (either triangle markers or boom length numbers), order the applicable items through your distributor.

Wire Rope Inspection

Safe operation of your Load King Boom Truck is dependent on the proper use of wire rope in all operations. The ideal situation is to remove a wire rope from service after receiving maximum service life, but without sacrificing safety. The end point of useful service life is determined by regular inspections of the wire rope by competent personnel.

OSHA and other agencies having jurisdiction, issue instructions governing the inspection of wire rope used on special equipment and in specified industries. All wire rope users are urged to comply with the law for their particular situation. Inspections must be carried out at stated intervals. When the data obtained from these inspections indicates that the strength of the wire rope has appreciably decreased, and that further use would constitute a safety hazard, the rope must be removed from service. It is the responsibility of the user to know what codes apply to his situation and to comply with their requirements.

In the interest of safety, Load King believes that any wire rope, where failure might endanger personnel, equipment, or the load, must be removed from service when any of the listed conditions are detected. We recommend a daily visual inspection of the entire length of rope, and a thorough inspection at least once per month - including a full written report that is dated, signed, and kept on file. The following conditions for removal of a wire rope from service should be regarded as a guide, with any specific regulations covering your equipment and industry taking precedence.

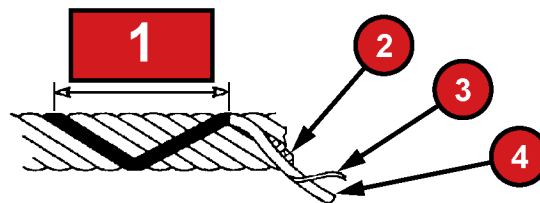

1	One Rope Lay Length	3	One Wire
2	Core	4	One Strand

- Six broken wires in one rope lay or three broken wires in one strand in one rope lay. One rope lay is the linear distance, measured along the rope, required by a strand to make one 360° turn around the axis.
- Wear of 1/3 of the original diameter of outside individual wires.
- Kinks, crushing, cuts, unstranding, or any other damage resulting in distortion of the rope structure, are cause for removal of rope from service.
- Heavy rusting, corrosion, pitting, or any evidence of burning, are cause for removal.
- Any reduction in rope diameters below nominal, for any reason, should be evaluated. A reduction in diameter of more than the following is cause for removal of the rope from service:

1/64"	For rope diameters up to and including 5/16"
1/32"	For rope diameters 3/8" through 1/2"
3/64"	For rope diameters 9/16" through 3/4"
1/16"	For rope diameters 7/8" through 1 1/8"
3/32"	For rope diameters 1 1/4" through 1 1/2"

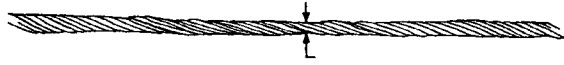

REDUCTION OF WIRE ROPE DIAMETER

Wire Rope Inspection Record

WIRE ROPE INSPECTION RECORD (Refer to Wire Rope User's Manual for Criteria)			
PLACE OF INSPECTION		DATE	
DESCRIPTION OF CRANE			
Make		Model	Serial No.
Type and arrangement of attachments			
Date of Last Rope Inspection			
Hours and Time of Service Since Last Inspection			
Results of Inspection			
Rope Inspected	Type and Size	Conditions Noted	Recommendations
	Inspector		

Mobile Crane Load Test Inspection

General

As a worldwide crane manufacturer, Load King does not recommend carrying out a regular overload test on mobile cranes.

An overload test after every change of location or crane reconfiguration is not a reliable and safe inspection method and can cause premature material fatigue.

In some countries, national laws require overload tests e.g. in accordance with information from the crane manufacturer.

Every mobile crane is subjected to a load test by the manufacturer within a final acceptance procedure before delivery. These tests are carried out with test loads in different configurations in accordance with the scenarios with the lowest safety reserves in relation to mechanical strength and stability of the crane. This includes an overload test with defined conditions and standards which can be applied accordingly.

Further acceptance tests with overloads during the cranes working life must only be carried out after modifications or repairs of load-bearing components or after an extensive overhaul. In some countries, national regulations may require tests with overload and/or overload tests before carrying out hoist work after any change to the crane configuration.

The calculation of the load-bearing structure of mobile cranes satisfies all applicable international standards (EN, ISO, FEM, etc.) and does not provide for continuous operation. The cranes therefore have a service life which is defined by the permitted number of working cycles. Any overloading of the crane can have a negative effect and leads to a reduction in the cranes service life. This can become a critical problem if the crane is tested with overload before every hoist operation (e.g. when building a wind farm with 80 to 100 wind turbines at one location within a few weeks).

Load King strictly prohibits operators to overload any crane. Safety equipment such as load limit devices prevent overloads being raised; the corresponding bridging / override switch is only provided for emergency situations or when the load limiter fails (as determined in the operating instructions).

Load and Overload Test

As the manufacturer, Load King does not recommend using the bridging / override switch regularly for overload tests and generally advises against regular overload tests - even including tests during which the test load is attached via external equipment without activating the bridging / override switch.

	<p>Decreased service life due to regular overload tests. As a manufacturer, Load King aims to avoid overload tests, as such tests decrease the service life of the cranes.</p>
---	---

The following aspects must also be taken into consideration from the viewpoint of the user/operator:

- Operational planning:
 - Higher floor loading than provided for,
 - difficult handling of the additional test load,
 - ban on carrying out any overload tests on-site in some fields of industry (e.g. petrochemical plants).
- Operational safety:
 - Anyone in the vicinity of the crane must be warned of the test procedure and
 - must leave the area during the test.



Risk of accidents due to damage to load-bearing parts

After an overload test, carry out extensive investigations to ensure the intactness of the load-bearing components.

Damage to load-bearing parts can occur due to cracks caused by overload and/or fatigue; such defects are not exposed by an overload test. For this reason, an overload test can give owners and operators a false sense of security.

To ensure the intactness of load-bearing components, extensive investigations are recommended after an overload test and before carrying out hoist work. Such an investigation consists of a visual inspection combined with function tests (including the safety equipment) and can necessitate non-destructive inspections such as magnetic particle or ultrasonic inspections.

Any malfunction or irregularity discovered during the inspection must be evaluated by an expert. This person must determine whether the movement can be carried out safely or whether immediate repair/modification is required.

Recommendations of Load King with Regard to Load Tests

Checking Assembly

Checking the correct crane assembly (e.g. after reconfiguration) must include:

- a visual inspection of all assembled parts on the ground before erecting the boom,
- a function check of the crane without or with limited load including:
 - any movements important for the job
 - an inspection of all limit switches (among others, the hoist limit switches),
- an inspection to ensure the assembly has been carried out in accordance with the assembly instructions.

Load Test Factors

If load tests are required by laws mandating checking the assembly of the crane, 100% of the permitted load of the crane in the given configuration must not be exceeded.

This applies to all Load King mobile cranes for the static and dynamic load tests. A period of 5 minutes is sufficient for static tests.

Load tests may be required by law.

- after assembling the crane or
- after changes in location.



The conditions listed above do not apply after reconfiguration or repairs to load-bearing crane parts. In this case, the load test factor can be higher (in accordance with the safety factors from the product standards). It is recommended to involve the crane manufacturer in such tests.

Load Test Configurations

If a load test is required (by law), the test conditions must correspond with the conditions during the scheduled lift. It is acceptable to Load King to carry out a load test for a given crane configuration with reduced loads (below the max. capacity), but at a greater radius, up to the maximum radius (max. load moment).

Reason: In lattice mast cranes, erecting the boom from the ground is one of the most critical load cases of a crane configuration with regard to load; erecting must therefore be regarded as a load test for the tension-carrying structures such as the lattice mast sections (with regard to pressure and bending stress), the bracing rods (tensile load), the boom adjustment winch, the Superlift mast, etc.

Job-Site

Job Site Setup Procedure

1. Position vehicle on solid level ground, fully set parking brake, and place transmission in neutral.
2. Engage pump PTO. Allow hydraulic oil to warm up by circulating to prevent pump damage. NEVER DRIVE VEHICLE WITH PUMP PTO ENGAGED.
3. Check hydraulic system filter indicator to confirm that filter is functioning properly.
4. Extend all outriggers to firm contact with solid level surface, and level vehicle. Raise the crane enough to lift the tires off the ground.
5. Always pay out winch line before extending boom. Failure to do so will result in the load block contacting the ATB switch which will shut down the boom extend function or damage the crane.
6. Always know your operating radius (distance from centerline of rotation to load hook), and the actual weight of load being lifted. Load radius may vary at different rotation positions.
7. Operation ahead of the main outriggers requires the use of an optional front bumper stabilizer. The least stable boom position is immediately ahead of the mainframe outriggers over the truck cab.
8. Consult manual for cold weather operation.

Outrigger Positioning

Before conducting any boom operation you must extend all outriggers to a firm and level surface. In the event that other conditions exist such as: loose or sandy soil, crusty or frosty surface with soft soil underneath, icy or slick pavement, sloping surfaces, etc., you will be required to restrict your operations. In some areas, you may be able to level your crane with the use of outrigger pads or blocks. These pads must be made of adequate material and should be a minimum of 2 inches in thickness. If the main outriggers can not be placed at or near the same level as the wheels, the outrigger spread will be affected. This can result in damage to the crane and/or instability.

OUTRIGGER POSITIONING - FOR LOAD HANDLING OVER SIDE OR REAR OF UNIT

The main outriggers should be extended first, then the auxiliary stabilizers. Optional front bumper stabilizer (if equipped) must be extended last. Raise the crane enough to lift the tires off the ground. The front tires should remain close to the ground when the unit is setup and leveled.

OUTRIGGER POSITIONING - FOR LOAD HANDLING OVER FRONT OF UNIT

The main outriggers should be extended first, then the auxiliary stabilizers. Front bumper outrigger is required for lifting over the front of the unit and must be extended last. The front tires should remain close to the ground when the unit is setup and leveled. When the load is being handled over the front of the truck, the front outrigger must be extended.

 **TO PREVENT STRUCTURAL DAMAGE TO THE CARRIER CHASSIS - THE OPTIONAL FRONT BUMPER STABILIZER (IF SO EQUIPPED) MUST BE EXTENDED LAST AND RETRACTED FIRST.**

 **OBSERVE CAUTION NOTES ON OUTRIGGER MOVEMENT WHENEVER SETTING UP OR STOWING OUTRIGGERS.**

Work Site Position

The best possible work site should always be sought when you are positioning the crane. An ideal location is where the ground is firm, level and dry. The crane should be situated in close proximity to the work area. The site should be free of overhead obstructions. Maintain safe clearances from electrical power lines and apparatus. You must allow for boom and platform sway, rock or sag, and electrical line and load line swaying.

&!- &A Operating Instructions

Cold Weather Operation

During cold weather operation the operator must allow the oil to warm up to operating temperature. This can be accomplished by allowing the hydraulic pump to run under no load for ten minutes at low engine speed. Next, actuate all the controls slowly until controls move smoothly and easy. In extreme cold, extra care must be taken to avoid any impact loading. Materials which are normally ductile can become brittle at extreme cold temperatures.



FAILURE TO ALLOW OIL TO WARM UP MAY CAUSE DAMAGE TO PUMP AND SLOW RESPONSE TO FUNCTION CONTROLS.

General Operational Issues

General Rules

1. Always operate controls to lower the load line while extending the boom. This will maintain clearance between boom tip and downhaul weight.
2. Make certain load line is not twisted or kinked, and that load line is properly seated on drum and in sheaves.
3. During winching, meter all controls and apply power smoothly - no sudden starts or stops.
4. When hoisting a load, raise it a few inches and allow controls to return to neutral to determine if winch brake and boom holding valves are working properly.
5. You must not make side pulls with the boom. This type of loading can damage the boom and rotation mechanism. Do not raise or lower a load in such a manner that would cause side loading.



OBSERVE CAUTION NOTES ON OUTRIGGER MOVEMENT WHENEVER SETTING UP OR STOWING OUTRIGGERS.

6. When lifting a load, you must always make certain that three (3) full wraps of rope remain on winch drum at all times. Maintain tension on the load line at all times to prevent rope from becoming twisted or kinked and to keep cable properly seated on drum and sheaves. When lifting loads that exceed the single part line limitation shown on your maximum load chart, consult chart instructions on how to multipart the load line.



WHEN USING A MULTIPART LOAD LINE, BOOM EXTENSION MUST BE LIMITED TO MAINTAIN (3) FULL WRAPS ON WINCH DRUM.

7. The proper maintenance and care of the wire rope load line on your Load King Boom Truck is most important. Refer to standard ANSI/ ASME B30.5 for wire rope inspection and maintenance procedures as well as special provisions for handling maximum rated loads with rotation resistant ropes. A rope inspection record is provided in the maintenance manual.
8. Load line loop and drum wedge must be properly seated inside winch drum before winding load line on winch drum. Refer to maintenance and installation manuals for instructions.

&!- &A Operating Instructions

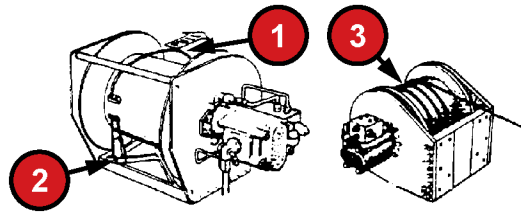

1	Load Line	3	Three Wraps Minimum
2	Drum Wedge		

Safety Devices

The safety devices on your Load King Boom Truck are described below. These devices will help you maintain control of a load should power or hydraulic line failure occur. You must understand the function and operation of these devices so that a continual check on their performance can be made.



SHOULD ANY OF THESE DEVICES FAIL TO FUNCTION, STOP ALL OPERATIONS AND CONSULT YOUR AUTHORIZED LOAD KING DEALER. THIS CRANE CAN BE OVERLOADED BY AN OPERATOR WHO FAILS TO FOLLOW THE INSTRUCTIONS CONTAINED IN THIS MANUAL.

BOOM LIFT CYLINDER HOLDING VALVE

A single acting holding valve is cartridge-mounted in the cylinder base. This valve holds the boom in the elevated position should power or hydraulic pressure line failure occur. Should any of these happen, “STOP NOW.” If the boom creeps down, consult your authorized Load King dealer.



NEVER, UNDER ANY CIRCUMSTANCES, REMOVE OR ATTEMPT TO REMOVE THE CARTRIDGE FROM THE LIFT CYLINDER BASE UNTIL AN AUTHORIZED MAINTENANCE PERSON IS PRESENT AND THE BOOM IS PROPERLY SUPPORTED AND BLOCKED. AN UNSUPPORTED BOOM CAN FALL UNCONTROLLED; CAUSING DEATH OR SERIOUS INJURY OR PROPERTY DAMAGE.

EXTENSION CYLINDER HOLDING VALVE

A holding valve is mounted to the cylinder rod end (boom base) for 2nd and 3rd stage extension (also 4th stage, if applicable). This valve holds the cylinder in the extended position should power or hydraulic pressure line failure occur. If the boom creeps in under load, consult your authorized Load King dealer.

OUTRIGGER CYLINDER HOLDING VALVE

All outriggers are equipped with internal cartridge type lock valves. If outriggers creep up under load, or down while roading, consult your authorized Load King dealer.

WINCH SAFETY BRAKE

To determine if the brake is working, set the outriggers, raise a load a few feet and release control handle. Shut truck engine off; actuate winch control handle in down direction. If the load creeps down, consult your authorized Load King dealer.

SWING DRIVE BRAKE (ROTATION GEARBOX)

The rotation gear drive has a spring-applied hydraulic release brake. To determine if the brake is working, set the outriggers, swing the boom and release the control handle. If the boom continues to swing, consult your authorized Load King dealer.

Training and Operator Qualifications

It is extremely important that you have a thorough knowledge of all the operating characteristics of your crane. This crane will not be safe if improperly used! Crane operation shall be limited to personnel with the following minimum qualifications:

1. Designated, competent and experienced persons. If required, a valid certification for operation must be on file.
2. Trainees or untrained persons under direct supervision of qualified persons.
3. Maintenance and test personnel, only if it is necessary for the performance of their duties.
4. Supervisors with a designated experienced person present.

Operators and trainees will meet the following qualifications:

1. An operator shall be physically and mentally capable of operating the unit.
2. Demonstrate ability to read and comprehend all placards, operator's manuals, codes, and other information pertinent to correct and safe crane operation.
3. Operator shall demonstrate to employer the ability to operate specific type of equipment or provide satisfactory evidence of qualifications and experience to do so.
4. Recognize and be responsible for all maintenance requirements of the crane operated by him/her or trainees under supervision.
5. If an operator becomes physically or mentally unfit, they shall disqualify themselves.

Operator Aids

ATB

The ATB system will sense the presence of the load block in close proximity to the boom tip and will automatically interrupt the operation of those boom functions which could bring the load block in contact with the boom tip. A warning horn will sound to alert the operator to the two-block condition.

Those boom functions which could be used to move the load block further from the boom tip will remain operational.

DO NOT RELY ON THE ATB DEVICE AS A WINCH HOIST STOP.

OUTRIGGER WARNING ALARM

The outrigger warning alarm will sound an audible signal whenever any outrigger leg is moving.



LOAD INDICATING EQUIPMENT ON THIS CRANE IS INTENDED ONLY AS AN AID TO SAFE OPERATION.

LOAD/RADIUS INDICATING ELECTRONICS SHOULD NOT BE RELIED UPON TO REPLACE THE USE OF CAPACITY CHARTS AND PROPER OPERATING PROCEDURES.

RATED CAPACITY INDICATOR (3B6 or Greer Microguard)

This system is designed to provide the operator with information on the load he/she is lifting and also help prevent overloading of the crane. In order for this system to be effective, the operator must read and understand the instructions contained in this manual.

When limits are reached, an overload warning is activated. At the same time, the crane movements that would increase the overload condition - such as hoist up, telescope out, and boom down will be stopped.

To reset the rated capacity indicator system telescope in, winch down, or boom up.

If the RCI system must be overridden for any reason, the "Cancel Alarm" button on the face of the rated capacity indicator display unit should be depressed for 5 seconds. At this point the system is overridden until the overload or ATB condition is removed. See the RCI system manual at the end of this book for more detail.



ABUSE OR MISUSE OF THE ATB/ RCI OVERRIDE CAN RESULT IN DEATH, SERIOUS INJURY, OR PROPERTY DAMAGE.

Load Handling Operations

Before moving a load, you must study the capacity placards carefully and adhere the load capacities and radii of operation given. During operations when lifting, swinging, or extending the load, the controls should always be metered when beginning or terminating movement to prevent sudden starting or stopping which imposes undue shock loads on the equipment. This is especially true when handling heavy loads and in extreme cold temperatures. Note that the least stable position for a standard mount (crane behind cab) is usually over the front of the truck. The optional front bumper mounted stabilizer must be used to lift in front of the main outriggers.

Max. Load and Boom Angle Charts

Using the Maximum Load Chart



360° operation requires the use of the optional front bumper outrigger.

The maximum load charts shown are located on the side of the pedestal. Their purpose is to show you the load capacities at various radii and boom angles. The boom lengths are color coded to match the colored stripe on the sides and bottom of the second stage boom.

The boom angle charts display the boom angle and are located on the base boom just above the operator's station.

The second stage boom has a color coded stripe corresponding to the various boom extensions.

The boom extension is synchronized so the operator has only to observe which color is showing on the second stage. By using this boom extension and reading the boom angle off the boom angle placard, the operator can determine the approximate operating radius and by using the maximum load that can be lifted if that radius is maintained.

The following is an example of how to use the load chart: (Sample load chart on following page):

1. Assume you have extended the boom until the orange stripe (86' Boom Extension) is exposed.
2. Using the boom angle indicator as your guide, you have raised the boom to 40° elevation.

Using the range diagram section of the maximum load chart, find the 40° angle line and follow it to the 53' arc. Then follow the vertical line down; the operating radius is approximately 40'.

Using the load rating section of the load chart, go across the top of the chart (boom length) to the 53' column and go down (operating radius) to 40' the number to the immediate right is the maximum load that can be lifted (i.e. 2,850 lbs.).

Since the boom will deflect as it is loaded the boom angle will have to be increased to maintain a loaded boom radius of 40'. If the boom is not raised up above 40° before lifting the load - the load will swing out, increasing the operating radius. THIS may cause an overload condition.



NOTE: *In an occurrence where the operating radius is between those listed on the chart, use the smaller maximum load number.*

&|- &A Operating Instructions



It is important that you know the weight of any material that you attempt to handle. This can be determined by use of a dynamometer or scales.

The maximum load chart shows the maximum lifted load. Maximum load is the weight of the material being handled plus such load handling equipment as slings, buckets, downhaul weights, etc. The weight of load handling equipment must be deducted from the maximum load rating to determine how much payload you can lift.

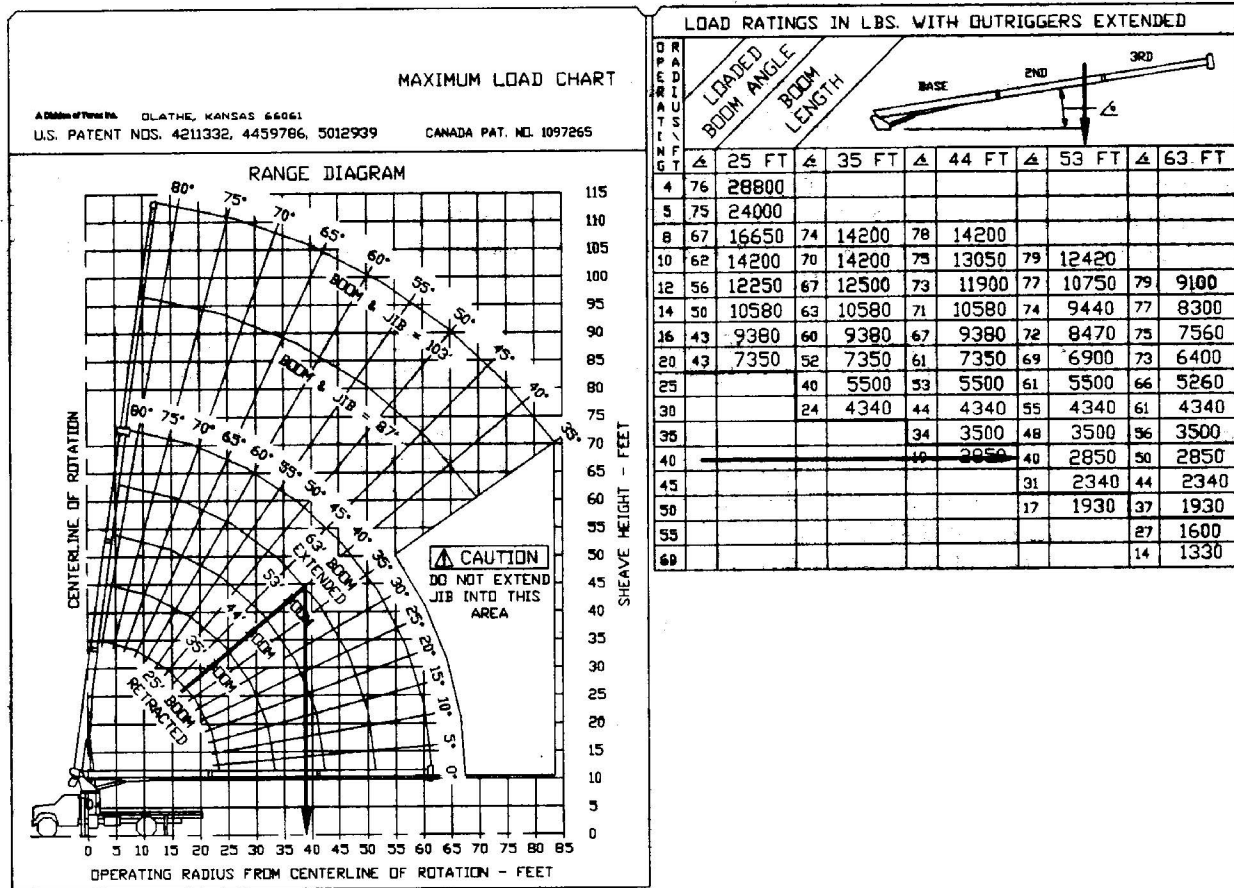

Swinging of a suspended load can cause the load to drift away from the crane. The drifting of the load away from the crane will increase the cranes operating radius. The increase in operating radius may cause the crane to tip or the boom to fail.



Bouncing or jerking of a load will cause shock loading to many critical parts of the crane. The shock loads may cause these critical parts to fail.

Operating Radius

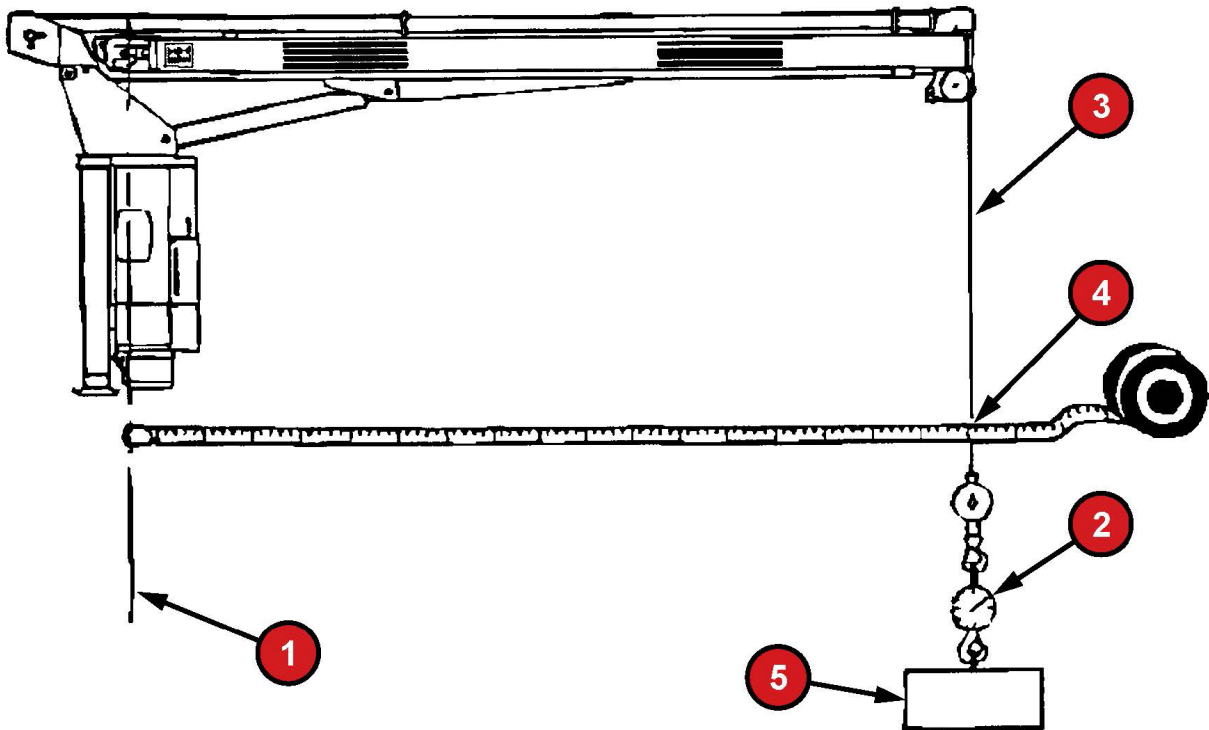

1	Center Line of Rotation	4	Read Operating Radius Here
2	Load Indicator	5	Weight (suspended)
3	Load Line		

&!- &A Operating Instructions

Boom Angle Placards

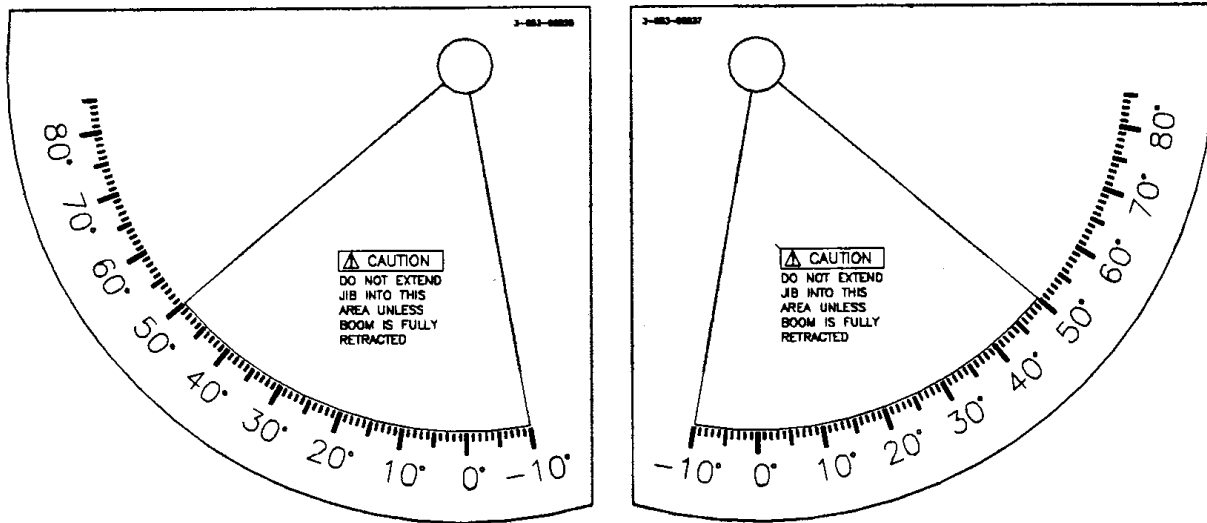

CAUTION - Do not extend jib into this area unless boom is fully retracted.

Operating the Unit

Operating the Unit

Now that you are familiar with the controls and function of the Load King Boom Truck, practice making some typical job applications. As with any piece of equipment, practice is required to develop the coordination and knowledge necessary for smooth and efficient operation.

&!- &A Operating Instructions

Initiating Operation

1. If possible, position the unit at the job site in such a manner as to assure all work operations can be performed without repositioning the truck (see [Work Site Position on page 101](#)). However, strict observance of load weight, radius and maximum load rating must always be complied with.
2. Set parking brake securely.
3. Place transmission in neutral and engage PTO.
4. Extend all outriggers to make firm contact with ground. (See [Outrigger Positioning on page 100](#).) Provide outrigger pads if terrain is soft or if outriggers tend to sink into ground. Properly level the machine using the console mounted bubble level.



IF UNIT IS EQUIPPED WITH OPTIONAL FRONT BUMPER MOUNTED STABILIZER, IT MUST BE EXTENDED LAST TO PREVENT STRUCTURAL DAMAGE.

While operating the crane, frequently check that proper level condition is maintained.





NOTE: Console mounted bubble levels must be periodically checked for proper adjustment. See *Maintenance manual* for more information.

5. Position yourself at the operator's console and accelerate the truck engine to desired speed. Maximum pump speed should not exceed 2,300 R.P.M.
6. Bring the hydraulic oil up to operating temperature. (See [Cold Weather Operation on page 102](#).)
7. Check all controls for proper operation. During all operations, the controls should be metered to prevent sudden starting and stopping.





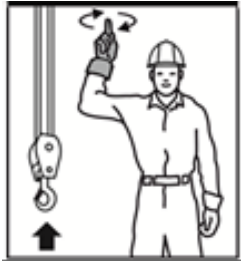
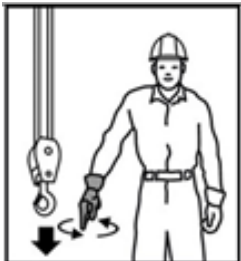

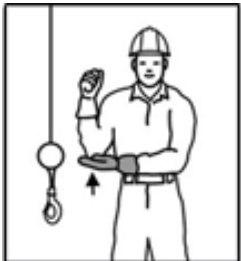

FAILURE TO METER YOUR CONTROLS INDUCES HIGH SHOCK LOADS ON THE EQUIPMENT WHICH MAY RESULT IN STRUCTURAL FAILURE OR OVERTURNING OF THE CRANE. DEATH OR SERIOUS INJURY MAY RESULT.

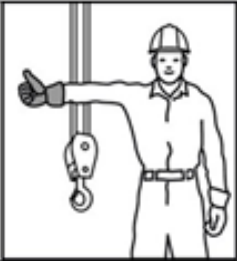
Arm and Hand Signals

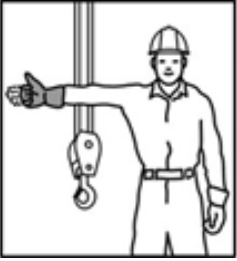
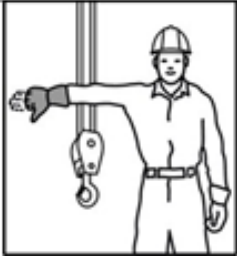
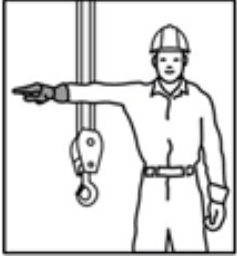

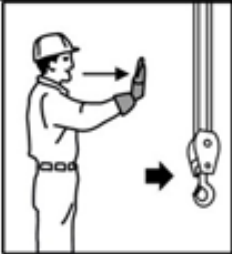

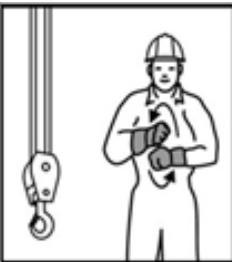
Hand Signals		
Graphic	Operation	Action
		
	STOP	Arm extended, palm down, move arm back and forth horizontally.
	LOWER	With arm extended downward, forefinger pointing down, move hand in small horizontal circle.
	USE MAIN HOIST	Tap fist on head; then use regular signals.
	USE WHIPLINE (Auxiliary Hoist)	Tap elbow with one hand, then use regular signals.

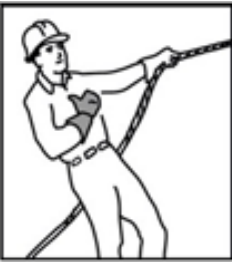
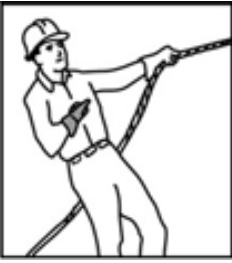
&!- &A
Operating Instructions

	<p>RAISE BOOM</p>	<p>Arm extended, fingers closed, thumb pointing upward.</p>
	<p>LOWER BOOM</p>	<p>Arm extended, fingers closed, thumb pointing downward.</p>
	<p>MOVE SLOWLY</p>	<p>Use one hand to give any motion signal and place other hand motionless in front of hand giving the motion signal. (Hoist slowly shown as example.)</p>
	<p>RAISE THE BOOM AND LOWER THE LOAD</p>	<p>With arm extended, thumb pointing up, flex fingers in and out as long as load movement is desired.</p>
	<p>LOWER THE BOOM AND RAISE THE LOAD</p>	<p>With arm extended, thumb pointing down, flex fingers in and out as long as load movement is desired.</p>
	<p>SWING</p>	<p>Arm extended, point with finger in direction of swing of boom.</p>

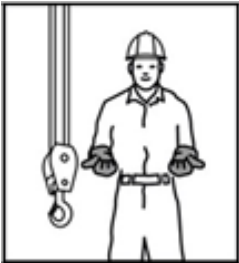
	<p>TRAVEL</p>	<p>Arm extended forward, hand open and slightly raised, make a pushing motion in direction of travel.</p>
	<p>DOG EVERYTHING</p>	<p>Clasp hands in front of body.</p>
	<p>TRAVEL (Both Tracks)</p>	<p>Use both fists in front of body, making a circular motion about each other, indicating direction of travel, forward and backward. (For land cranes only.)</p>
	<p>TRAVEL (One Track)</p>	<p>Lock the track on side indicated by raised fist. Travel opposite track in direction indicated by circular motion of other fist, rotated vertically in front of body. (For land cranes only.)</p>
	<p>EXTEND BOOM (Telescoping Boom)</p>	<p>One Hand Signal. One fist in front of chest with thumb tapping chest.</p>
	<p>RETRACT BOOM (Telescoping Boom)</p>	<p>One Hand Signal. One fist in front of chest, thumb pointing outward and heel of fist tapping chest.</p>

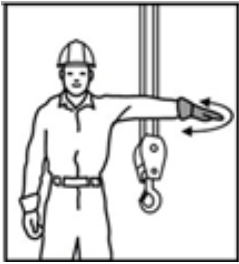
&!- &A Operating Instructions

	<p>EXTEND BOOM (Telescope Boom)</p>	<p>Both fists in front of body with thumbs pointing outward.</p>
	<p>RETRACT BOOM (Telescoping Boom)</p>	<p>Both fists in front of body with thumbs pointing toward each other.</p>
	<p>STOP</p>	<p>Arm extended, palm down, move arm back and forth horizontally.</p>
	<p>EMERGENCY STOP</p>	<p>Both arms extended, palms down, move arms back and forth horizontally.</p>

Lifting the Load

Follow recommended procedures for work site position, outrigger positioning, and control metering.

Always inspect downhaul weight, load line, hook and/ or any load handling equipment for damage or excessive wear before use.

The following general instructions should be adhered to each time a lifting operation is performed.



IT IS IMPORTANT THAT YOU KNOW THE WEIGHT OF ANY MATERIAL THAT YOU ATTEMPT TO HANDLE. THIS CAN BE DETERMINED BY USE OF A DYNAMOMETER OR SCALES.

STEPS TO LIFTING A LOAD

1. Determine what the total load weighs.



NOTE: *Total load includes the weight of the material being lifted plus any material handling devices such as slings, yokes, personnel platforms, load blocks, jib deducts, etc.*

2. Consult the maximum load chart on your crane and determine the correct boom radius and parts of line required based upon your load weight.
3. Check the configuration setting number for the Microguard 586 RCI - It must match the actual crane configuration (Including parts of line rigged).
4. Rotate the boom tip until it is directly over the material to be lifted. Unless continuous rotation is specified, Load King Boom Trucks are equipped with 370° rotation stops. It is important that you be aware of the position of the stops before lifting in order to assure maximum rotation and prevent excess handling of the load. The stops are generally over the front of the truck.
5. Attach load line to material and begin operation. Observe proper sling or chain usage and make sure any load handling attachment used has adequate size and capacity for the load being lifted.



THE RATED CAPACITY INDICATOR SYSTEM DOES NOT PROTECT THE CRANE WHEN THE BOOM IS OPERATED BELOW HORIZONTAL.

Observe position of boom and load at all times. The rated capacity indicator system does not protect against shock loads or side loading.

Emergency Procedures

Emergency Procedures

When operational aids are inoperative or malfunctioning, the following requirements shall apply for continued use or shutdown of the crane.

1. Steps shall be taken to schedule repairs and recalibration immediately. The operational aids shall be put back into service as soon as replacement parts, if required, are available and the repairs and recalibration can be carried out. Every reasonable effort must be made to expedite the repairs and recalibration.
2. When a load indicator, rated capacity indicator, or rated capacity limiter is inoperative or malfunctioning, the designated person responsible for supervising the lifting operations shall establish procedures for determining load weights and shall ascertain that the weight of the load does not exceed the crane ratings at the radius where the load is to be handled.
3. When a boom angle or radius indicator is inoperative or malfunctioning, the radius or boom angle shall be determined by measurement.
4. When an ATB device, two-blocking damage prevention, or two-block warning device is inoperative or malfunctioning, the designated person responsible for supervising the lifting operations shall establish procedures, such as assigning an additional signal person, to furnish equivalent protection.
5. When a boom length indicator is inoperative or malfunctioning, the designated person responsible for supervising the lifting operations shall establish the boom length at which the lift will be made by actual measurement or marking on the boom.
6. When a level indicator is inoperative or malfunctioning, other means shall be used to level the crane within the level requirements specified by the manufacturer.

In certain situations, It may be necessary to override the automatic motion limiter of the RCI/ATB unit in order to safely operate the crane. These include, but are not limited to:

The load block may lift the ATB weight before the load line can be tensioned while stowing the boom. This will cause a motion cutout. Overriding the system, in this situation is acceptable in order to continue to winch in slack line, securing the boom.

Emergency Boom Retraction

The Load King Stinger Boom Truck is equipped with a pilot operated holding cartridge in the base of the extension cylinder. This cartridge provides a means of supporting loads in a static condition to prevent any inward creep. It also provides support in the event of a ruptured line, or hydraulic failure.

These holding cartridges should be maintained in a condition to hold a rated load suspended with the power source shut off and the handle actuated to the retract position.

Although we DO NOT recommend that you adjust this cartridge, it may be used as an emergency retraction device in the case of ruptured lines or pump failure. This may be accomplished with the following procedures:

1. Have qualified operator (per ANSI B30.5) hold the extend handle in the retract position.
2. Loosen the nut on the counterbalance cartridge and rotate the screw very slowly clockwise until inward movement is noticed. Be sure to count the turns so the cartridge may be returned to original adjustment.
3. If the boom is not elevated sufficiently, friction may hold it in place. An external load may need to be applied against the boom tip to retract the boom.



APPLY FORCE VERY CAREFULLY SO AS NOT TO DAMAGE ANY BOOM COMPONENT. IF BOOM WILL NOT RETRACT, DO NOT FORCE IT OR INTERNAL DAMAGE MAY RESULT.

Emergency Lowering of Boom

The Load King Stinger Boom Truck is equipped with a pilot operated holding cartridge in the base of the lift cylinder. This cartridge provides a means of supporting loads in a static condition to prevent any downward creep. It also provides support in the event of a ruptured line, or hydraulic failure.

This holding cartridge should be maintained in a condition to hold a rated load suspended with the power source shut off and the handle actuated in the down position.

Although we DO NOT recommend that you adjust this cartridge, it may be used as an emergency lowering device in the case of ruptured lines or pump failure. This may be accomplished with the following procedures:

1. Have qualified operator (per ANSI B30.5) hold the topping handle in the down position.
2. Loosen the nut on the counterbalance cartridge and rotate the screw very slowly clockwise until downward movement is noticed. Be sure to count the turns so the cartridge may be returned to original adjustment.
3. Regulate boom down speed with the control handle.



DO NOT PUT ANY PART OF YOUR BODY BETWEEN THE LIFT CYLINDER, THE BOOM, OR THE TURRET. CRUSHING INJURY OR DEATH CAN OCCUR.

Emergency Rotation

The Load King Stinger Boom Truck is equipped with a spring applied, pressure released rotation brake. This brake will only allow rotation if there is sufficient hydraulic pressure. In case of hydraulic failure this brake will have to be HYDRAULICALLY released. This may be accomplished with the following procedures:

1. Use emergency retraction procedures to fully retract the boom.
2. Use emergency lowering procedures to lower the boom about 1 foot above the boom rest. Attach a tag line to the boom..
3. Plumb a PORT-A-POWER or other hydraulic source into the brake port on the rotation gearbox..
4. Remove counterbalance valve cartridges from motor..
5. Pressurize the brake port to 600 PSI and rotate boom over boom rest with a tag line. Oil will be lost through counterbalance valve cavities as the boom is rotated. Catch any spilled oil in a pan..
6. Release hydraulic pressure and reattach brake line. Reinstall counterbalance valves..



ONCE BOOM IS IN BOOM REST, USE STRAPS TO SECURE BOOM INTO BOOM REST FOR ROADING. IF HOOK BLOCK OR LOAD BALL CANNOT BE SECURED TO TIEDOWN POINT, REMOVE IT AND SECURE ANY LOOSE WINCH CABLES.

Emergency Retraction of Outriggers

The Load King Stinger Boom Truck is equipped with pilot operated holding cartridges in both parts of the outrigger cylinder. The extend cartridges provide a means of supporting loads in a static condition to prevent any upward creep of the outrigger legs. They also provide support in the event of a ruptured line, or hydraulic failure. The retract cartridges hold the outriggers in position during roading

These holding cartridges should be maintained in a condition to hold a rated load suspended with the power source shut off and the handle actuated in the retract position.

These cartridges may be used as an emergency retraction device in the case of ruptured lines, or hydraulic pump failure. This may be accomplished with the following procedures:

1. Have qualified operator (per ANSI B30.5) hold the outrigger handle in the retract position.
2. Loosen the jam nut on the extend holding valve cartridge. Rotate the screw very slowly clockwise using a 3/16" allen wrench until inward movement is noticed. Once the truck tires are on the ground, further retraction will require the use of a jack or Come-Along. After adequate ground clearance is obtained, secure the outriggers in the retracted position with a chain or sling. Then return the holding valve cartridge to its original setting. Finally, remove the jack or Come-Along. The chain or sling should be left in place until the hydraulic system is restored to proper working order.

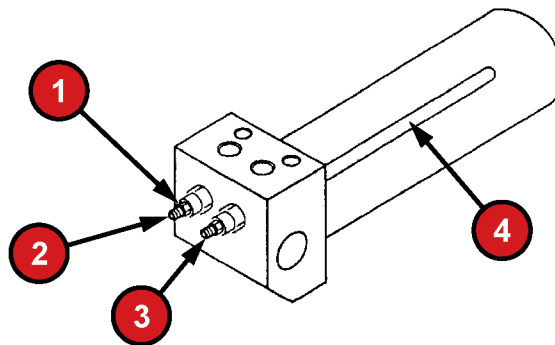

1	Jam Nut	3	Retract Cartridge
2	Extend Cartridge	4	Cylinder Retract Tube

	NEVER RETRACT THE OUTRIGGERS UNTIL THE BOOM IS SECURED INTO THE BOOM REST FOR ROADING.
---	---

Roading the Unit

Before leaving the work site or repositioning the crane at the work site, always:

1. Retract boom. Stow boom on the boom rest. Always use the boom rest.
2. Using D-Ring on rear of truck, attach load line hook and hoist in until slack is taken up. On tractor mount models, always use boom rest for securing the boom and tie off load line hook to attachment provided



NEVER LEAVE BOOM ELEVATED OR LOAD SUSPENDED WHEN UNIT IS UNATTENDED.

3. Fully retract all outriggers.



IF UNIT IS EQUIPPED WITH OPTIONAL FRONT BUMPER MOUNTED STABILIZER, IT MUST BE EXTENDED LAST TO PREVENT STRUCTURAL DAMAGE.

4. Disengage Power Take Off (PTO).
5. Secure any load or lifting attachments (steel platforms, roofer's package) to the flatbed.
6. The Load King Boom Truck is not a Pick and Carry Crane. Never drive truck with boom extended or elevated, or with a load suspended from load line hook.



NEVER LEAVE THE WORK SITE OR REPOSITION THE TRUCK CRANE WITHOUT FIRST SECURING THE BOOM IN ROAD TRAVEL POSITION AND FULLY RETRACTING ALL OUTRIGGERS.

&!- &A Operating Instructions

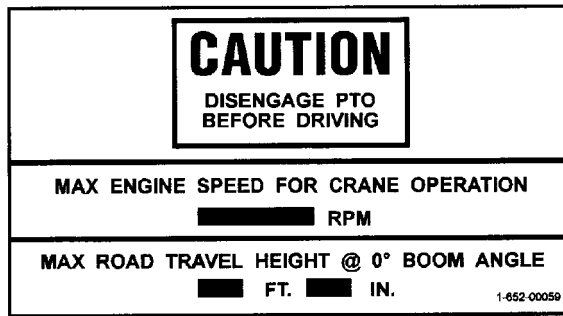

You should always know the maximum road height of your crane when repositioning at the job site or preparing for road travel. A placard like the one shown above, which shows the height of your crane as manufactured and installed is attached to the dash board inside the truck cab. Severe personal injury, as well as damage to the crane and truck, can result from failure to observe overhead obstructions during repositioning at the job site or during road travel.

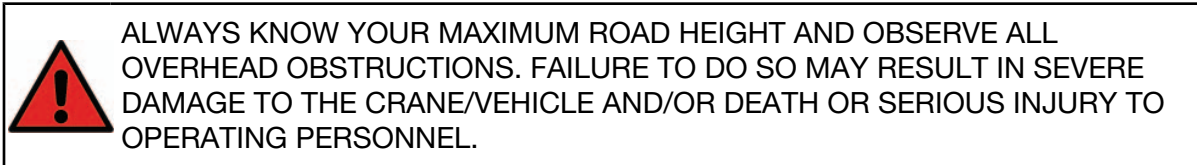

Safety Practices

1. ALWAYS apply the parking brake on the truck before undertaking any repairs to the crane.
2. Lower all loads to the ground so load line is slack.
3. Move all controls to neutral position.
4. Disengage the PTO and turn off ENGINE
5. Attach a caution sign to the start controls warning personnel that the unit is being serviced.
6. DO NOT stick hands or tools into any hole in boom sections while power is on or boom sections are moving.
7. DO NOT perform maintenance, adjustment, or repair procedure unless authorized to do so. Make sure all applicable instructions have been read and are understood thoroughly.
8. DO NOT check for hydraulic leaks with hands. Oil under pressure can penetrate human skin causing serious injury. Oil under pressure can be nearly invisible; Check for hydraulic leaks with a piece of cardboard or wood.



DO NOT GO NEAR LEAKS

1. High pressure oil easily punctures skin causing serious injury, gangrene or death.
2. If injured, seek emergency medical help. Immediate surgery is required to remove oil.
3. Do not use finger or skin to check for leaks.
4. Lower load or relieve hydraulic pressure before loosening fitting.

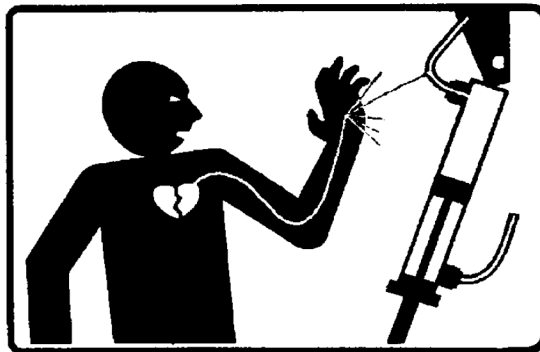

9. Hydraulic oil is flammable; DO NOT check inside hydraulic tank with an open flame.

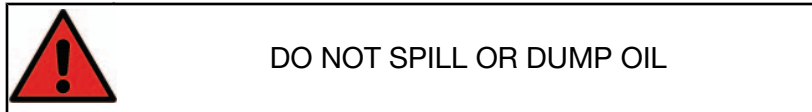

1. Keep open flame away.
2. Injury could result if not cleaned up.
3. Oil is a regulated/hazardous waste.
4. Capture oil when repairing or draining systems.
5. Disposal must conform to state/federal regulations.
6. Do not overfill containers or reservoirs.

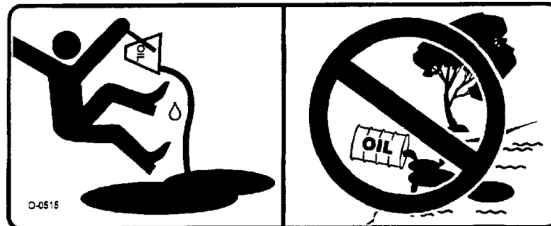

10. DO NOT alter specified flow and pressure settings. Higher than specified flows and pressures can cause damage to crane and hydraulic components. Lower than specified flows and pressures can result in loss of power.
11. DO NOT weld or have open flame close to hydraulic lines and components without first placing a protective cover over them.
12. DO NOT remove cylinders until working parts are resting on the ground or are securely blocked from movement.
13. Components are heavy. DO NOT attempt to lift them by hand; use a hoist, jacks, or blocking
14. This Boom Truck has a step and two grab handles on either side for climbing onto and off of the platform. Crane owner/user shall provide sturdy ladders for personnel to gain access to components which cannot be reached from either the platform or from the top of the flatbed. DO NOT allow personnel to climb onto turntable, winch, or the top of the boom. Use a sturdy ladder to gain access to these locations.

Cold Weather Package Specification

The Load King Stinger Boom Trucks can operate in temperatures down to -25C (-12F). For operating below this temperature a Cold Weather Package option would be required. With this package the crane can operate to -40C (-40F). To operate in these extreme weather conditions, proper start up and recommended operating procedures must be followed.

The following Cold Weather Package option must be installed as listed in chart below:



Fluids and lubricants must be compatible with the expected temperature environment. Refer to chart of recommended fluids for expected temperatures. Hydraulic and transmission systems must be drained and purged of old fluids to allow the maximum exchange for new fluids. Other fluids/lubricants can be exchanged by draining old fluids/refilling with recommended fluids or by applying recommended greases. Use of improper fluids for ambient conditions can damage equipment.

COLD WEATHER PACKAGE COMPONENTS

Description	SPEC. NO.	Load King Part No.
Main & Aux. Winch, Swing Drive	Mobil Gear SHC 150 or Shell OMALA HD 150	T117493
Hydraulic Oil-see data sheet	Petro-Canada Hydrex Extreme or Shell Tellus Arctic 32	T117487
Hydraulic Tank Heater	120V or 240V	A38556
Grease (upper structure & outriggers)	Mobilith SHC 220 Schaeffer 274 Moly EP Shell Alvania EP Arctic Moly O	T117494

1. Engine Oil-contact your local carrier truck supplier.
2. Gear Oil-Front & Rear Axles-contact your carrier truck supplier.
3. Transmission Fluid-contact your carrier truck supplier.
4. Coolant Fluid-contact your carrier truck supplier.
5. Grease (Carrier Chassis)-contact your carrier truck supplier.
6. Battery Blanket-contact your carrier truck supplier.
7. Engine Oil Pan Heater-contact your carrier truck supplier.
8. Fuel Pre-heater-contact your carrier truck supplier.

General Work Practices

The following points are effective work practices that make the job go smoother and provide for the best quality in the repair of the crane.

1. Before disconnecting wires, hoses or tubes, tag them for proper identification at reassembly.
2. Before removing a component (pump, motor, valve, etc.), match mark its mounting position in relation to the adjacent component
3. Before disassembling any multiple section component (pump, motor, valve, etc.), mark the position of each section in relation with the other.
4. Before removing shims, tie them together and identify the location.

Storing Components

1. Store new components (valves, pumps, motors, cylinders, hoses, tubes, fittings) in a clean, dry indoor location.
2. DO NOT unpack components or remove port plugs until the components are needed.
3. Once unpacked, carefully inspect each component for damage that may have occurred during shipping. Remove all shipping material from the ports of the components before installing them.
4. Fittings, hoses and tubes that are not equipped with shipping caps or plugs must be carefully cleaned before they are used. Flush the fittings, hoses and tubes with clean hydraulic oil then seal all openings until assembly.











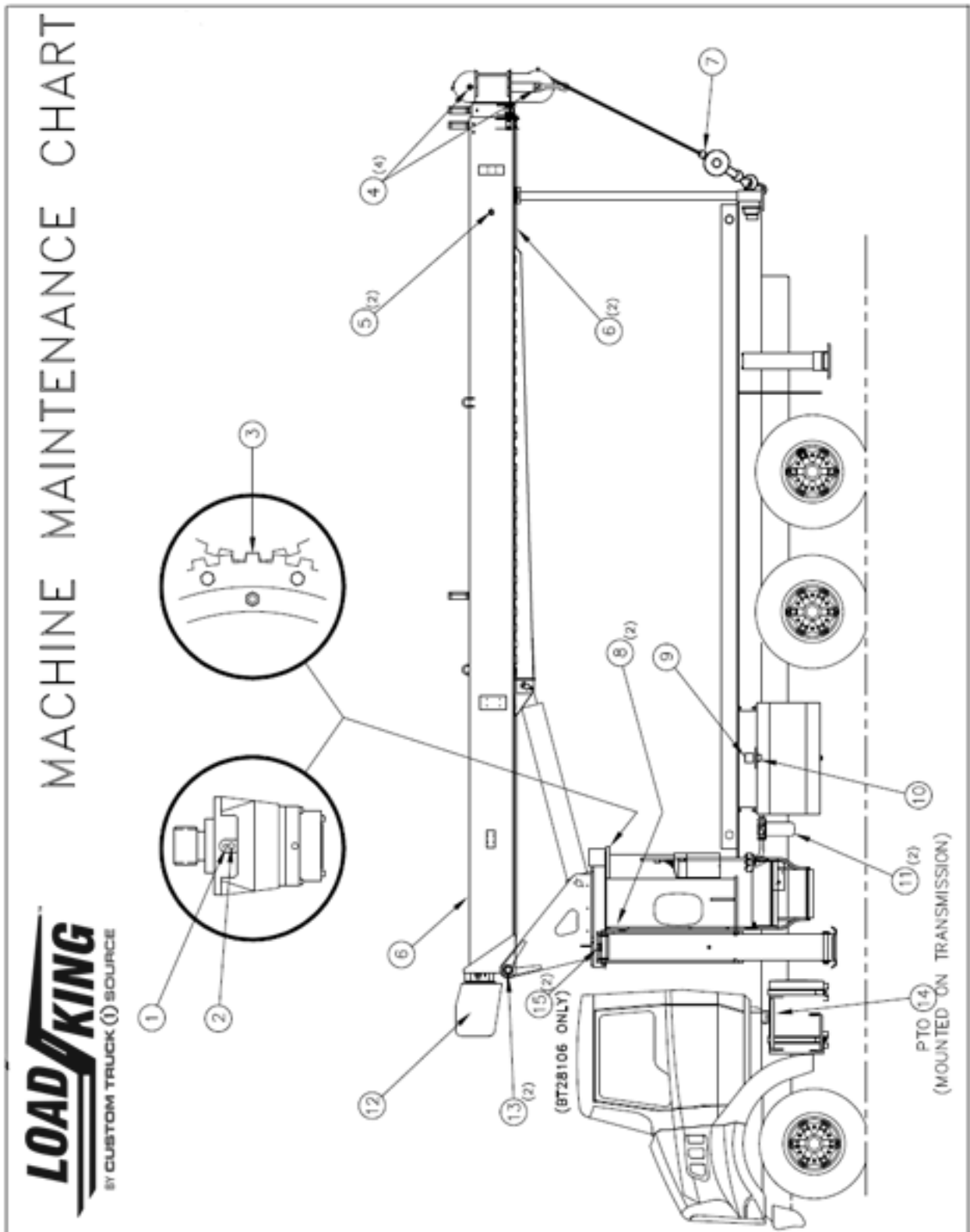























DO NOT USE RAGS TO PLUG OPENINGS. USE CLEAN PLASTIC OR METAL PLUGS AND CAPS.

Cleanliness

1. When removing a component from the crane, thoroughly clean the area around it to prevent dirt from entering the mating component or the hydraulic system. Cover all openings with plastic to prevent dirt and water from entering.
2. Carefully clean the area around fittings before disconnecting hoses and tubes and the mating ports of all components to prevent dirt and water from entering.
3. Use tools that are clean and in proper working condition.
4. Clean metal parts in nonflammable safety solvent. Clean rubber parts in warm soap and water. Lubricate all parts with clean oil at assembly, unless otherwise instructed.

BT70100 Master Lube Chart



				LEGEND:				
				CHK = CHECK	MPG = MULTI-PURPOSE GREASE, EP2			
				LUBE = LUBRICATE	PGO = PLANETARY GEARBOX OIL			
				C/F = CHANGE FILTER	HO = HYDRAULIC OIL, ISO 32			
				D/R = DRAIN & REFILL	N/A = NOT APPLICABLE			
8 HOURS OR DAILY	40 HOURS OR WEEKLY	150 HOURS OR MONTHLY	450 HOURS OR THREE MONTHS	900 HOURS OR SIX MONTHS	REF	DESCRIPTION	QUANTITY	LUBRICANT
	LUBE				1	SWING DRIVE GREASE FITTING  	AS REQ'D	MPG
		CHK	D/R		2	SWING DRIVE FILL PLUG  	FILL PLUG LEVEL	PGO
	LUBE				3	SWING GEAR TEETH  	AS REQ'D	MPG
	LUBE				4	SHEAVE PINS  	AS REQ'D	MPG
	LUBE				5	EXTEND CABLE SHEAVES   	AS REQ'D	MPG
	LUBE				6	ALL SIDES OF BOOM  	AS REQ'D	MPG
	LUBE				7	LOAD BALL PIVOT  	AS REQ'D	MPG
	LUBE				8	SWING BEARING GREASE FITTINGS  	AS REQ'D	MPG
		C/F			9	OIL BREATHER 	REPLACE	N/A
CHK					10	HYDRAULIC SYSTEM RESERVOIR  	CHK & FILL AS REQ'D	HO
		C/F			11	HYDRAULIC SYSTEM FILTER 	REPLACE	N/A
		CHK	D/R		12	WINCH  	FILL PLUG LEVEL	PGO
	LUBE				13	RETRACT CABLE SHEAVES   	AS REQ'D	MPG
	LUBE				14	PTO  	AS REQ'D	MPG
		LUBE			15	O/R PIN AT CYLINDER (BT28106 ONLY)  	AS REQ'D	MPG
			CHK		16	CHECK TORQUE ON BOLTS 	ALL	N/A

NOTE:  Reduce all lubrication intervals under severe operating conditions. Refer to Operator's Manual for drain/refill procedures and additional information. Check outrigger beams daily and remove excess dirt.

 See Operator's Manual.

 Grease w/Boom Fully Retracted

 Acceptable Planetary Gearbox Oils: 10° to 100°F (-12° to 38°C) AGMA 4 EP, ISO VG 150; 25° to 130°F (-4° to 54°C) AGMA 5 EP, ISO VG 220; -30° to 130°F (-34° to 54°C) Mobilgear SHC 150 or 220

T137469 REV B

1. SWING DRIVE GREASE FITTING - LUBE @ 150 HRS. OR MONTHLY
2. SWING DRIVE FILL PLUG - CHECK @ 450 HRS.- DRAIN AND REFILL @ 900 HRS. OR SIX MONTHS
3. SWING GEAR TEETH - LUBE @ 40 HRS. OR WEEKLY
4. SHEAVE PINS - LUBE @ 40 HRS. OR WEEKLY
5. EXTEND CABLE SHEAVES - LUBE @ 40 HRS. OR WEEKLY
6. ALL SIDES OF BOOM - LUBE @ 150 HRS. OR MONTHLY

7. LOAD BALL PIVOT - LUBE @ 40 HRS. OR WEEKLY
8. SWING BEARING GREASE FITTINGS - LUBE @ 150 HRS OR MONTHLY
9. OIL BREATHER - CHANGE FILTER @ 450 HRS. OR THREE MONTHS
10. HYDRAULIC SYSTEM RESERVOIR - CHECK EVERY 8 HRS OR DAILY
11. HYDRAULIC SYSTEM FILTER - CHANGE FILTER @ 150 HRS OR MONTHLY
12. WINCH - CHECK @ 450 HRS. OR THREE MONTHS - DRAIN AND REFILL AT 900 HRS OR SIX MONTHS
13. RETRACT CABLE SHEAVES - LUBE @ 8 HRS OR DAILY
14. PTO - LUBE @ 150 HRS. OR MONTHLY
15. O/R PIN AT CYLINDER (28-106 ONLY) - LUBE @ 450 HRS. OR THREE MONTHS
16. CHECK TORQUE ON BOLTS - CHECK AT 900 HRS. OR SIX MONTHS

LEGEND	
CHK	CHECK
LUBE	LUBRICATE
C/F	CHANGE FILTER
D/R	DRAIN & REFILL
MPG	MULTI-PURPOSE GREASE, EP2
PGO	PLANETARY GEARBOX OIL
HO	HYDRAULIC OIL
N/A	NOT APPLICABLE



NOTE: Δ 1. Reduce all lubrication intervals under severe operating conditions. Refer to Operator's Manual for drain/refill procedures and additional information. Check outrigger beams daily and remove excess dirt.

Δ 2. See Operator's Manual.

Δ 3. Grease w/Boom Fully Retracted.

Δ 4. Acceptable Planetary Gearbox Oils: 10° to 100°F (-12° to 38°C) AGMA 4 EP, ISO VG 150; 25° to 130°F (-4° TO 54°C) AGMA 5 EP, ISO VG 220; -30° to 130°F (-34° to 54°C) Mobilgear SHC 150 or 220.

Maintenance Checks and Lubrication

The following are the recommended maintenance instructions for the Load King Boom Truck. The unit is equipped with special Teflon bushings at the lift cylinder and boom hinge pin points that do not require lubrication. The outrigger hinge points do not require lubrication either. It is recommended that an EP (Extreme Pressure) type grease be used where greasing is indicated. The MASTER LUBE CHART above shows the proper lubricants to use and the frequency of lubrication.

DAILY OPERATOR CHECKS

A regular schedule of maintenance is essential to keep your unit at peak operating efficiency. Operators responsible for the care of the unit should be familiar with the daily and weekly maintenance schedules and what to look for. Below are the items to check to ensure the unit is in proper and safe operating condition, and recommended intervals of care.

CHECKING THE TRUCK

Proper operation of the crane is dependent on the condition of the truck, so the following checks should be done daily:

1. Set parking brake, start engine, put transmission in neutral and engage PTO. Allow the hydraulic system to warm up slightly. Check for any sign of oil leaks or damaged hoses. (See Hydraulic Hose topic in Maintenance section).
2. Extend all four outriggers to a firm surface, raise truck to just clear tires from ground, and shut the engine off. Move outrigger handles to unload any oil trapped in the hoses. This is an opportunity to ensure the outrigger holding cartridges are not leaking under load.
3. Check the lights for proper operation.
4. Check engine fluids. Maintain oil and water levels above the add mark.

Do additional checks per truck operator's manual.

DAILY CHECKS

Before daily operation begins, the crane should be run and checked for the following:

1. Set parking brake, start engine, put transmission in neutral and engage PTO. Allow the hydraulic system to warm up slightly. Check for any sign of oil leaks or damaged hoses. (See Hydraulic Hose topic in Maintenance section)
2. Extend all four outriggers to a firm surface, raise truck to just clear tires from ground, and shut the engine off. Move outrigger handles to unload any oil trapped in the hoses. This is an opportunity to ensure the outrigger holding cartridges are not leaking under load.
3. Check all controls for any signs of sticking and proper operation of functions. With boom elevated and extended, shut off engine, move topping and extension control handles, and check for signs of boom drift.

4. Check to make certain that the load line is properly spooled on the winch drum and that it is not damaged.
5. Check all Operator Aids for proper operation (ATB, RCI and Holding Valves).
6. Do daily lubrication.
7. Check that the downhaul weight (load block or ball) is properly secured to the loadline and the hook safety latch is in proper operating condition.

WEEKLY CHECKS

The following weekly checks should be performed in addition to the daily checks:

1. Check mechanical linkages for signs of wear or binding. Lubricate as necessary with 10 weight motor oil.
2. With all boom sections retracted, move boom side to side and check for missing wear pads between boom sections and excess clearance or looseness in rotation gearbox (more than 2"-4" of play side to side at boom tip).
3. If machine is salt covered, wash weekly to prevent rust and corrosion.
4. Do weekly lubrication.

MONTHLY OPERATIONAL CHECKS

The following checks should be performed monthly in addition to the daily and weekly checks:

1. Check oil level in the rotation gearbox. It should be filled with HD-80W90 to the fill plug. At this time a shot of grease should be added to the grease zerk on the upper bearing. (Caution: Do not overgrease this bearing!)
2. Check for excessive movement in the rotation gear mechanism. If over 4" of movement (side to side) is detected by moving the boom tip back and forth when fully retracted, it would be considered excessive. (See Care and Maintenance of the Rotation System topic in Maintenance section.)
3. Inspect all crane mounting bolts for signs of looseness or breakage. Replace or retorque where necessary. (See [Torque Specs-SAE & Metric on page 243.](#))
4. Extend all boom sections and check for physical defects, cracks and signs of overstress. Check the boom while extending to make sure it is properly sequencing. With the boom fully extended, check for excessive droop. Check the torque on the retraction cables (torque must be at 30-35 ft/lbs). Check to make certain all boom wear pads are in place and tight, and no excessive slop between boom sections is detected. (If repair is indicated, see [Wear Pad Adjustment and Replacement on page 206.](#))
5. Check that all boom and outrigger pins are properly secured and make certain that keepers and snap rings are present and properly installed.
6. Inspect load line for signs of kinking, crushing, cutting, or other damage.
7. Inspect weldments for signs of cracks at weld joints on all structural members.

8. Lubricate PTO with multi-purpose grease



1 Shaft Cover Screws

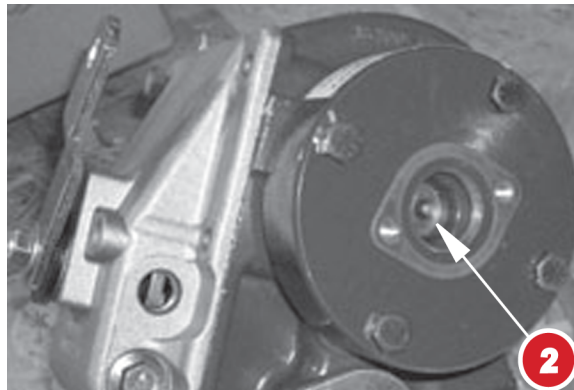

2 Grease Zerk

PTO Lubrication Instructions:

1. Remove Shaft cover Screws (1) and remove cover.
 2. Using grease gun, apply 2-3 pumps of multipurpose grease through grease zerk (2).
 3. Replace shaft cover and tighten screws.
9. Change hydraulic oil filter.

Hydraulic Oil Requirements

The hydraulic system is filled with a Shell Tellus S2 V 46 premium hydraulic oil. This hydraulic oil is recommended for a broad range of operating temperatures but the end user is ultimately responsible for determining if the oil is appropriate for their specific operating conditions or if another hydraulic oil is required. To ensure the longest life for this piece of equipment, it is critical to maintain the hydraulic oil at the proper level, to keep the hydraulic fluid clean (see Hydraulic Maintenance section), and to avoid overheating the oil.

The oil for the hydraulic system performs multiple functions. While the hydraulic oil must transmit power and provide superior lubrication under high pressure, there are other properties that are critical to the oil and the performance of the equipment. These include, but are not limited to, wear protection, oil oxidation, rust and corrosion protection and foaming. To guide in the selection of the proper oil, refer to the [Oil Viscosity Selection Chart on page 140](#) and the listings of [Typical Qualified Hydraulic Oils on page 141](#) below.

Oil Viscosity Selection Chart

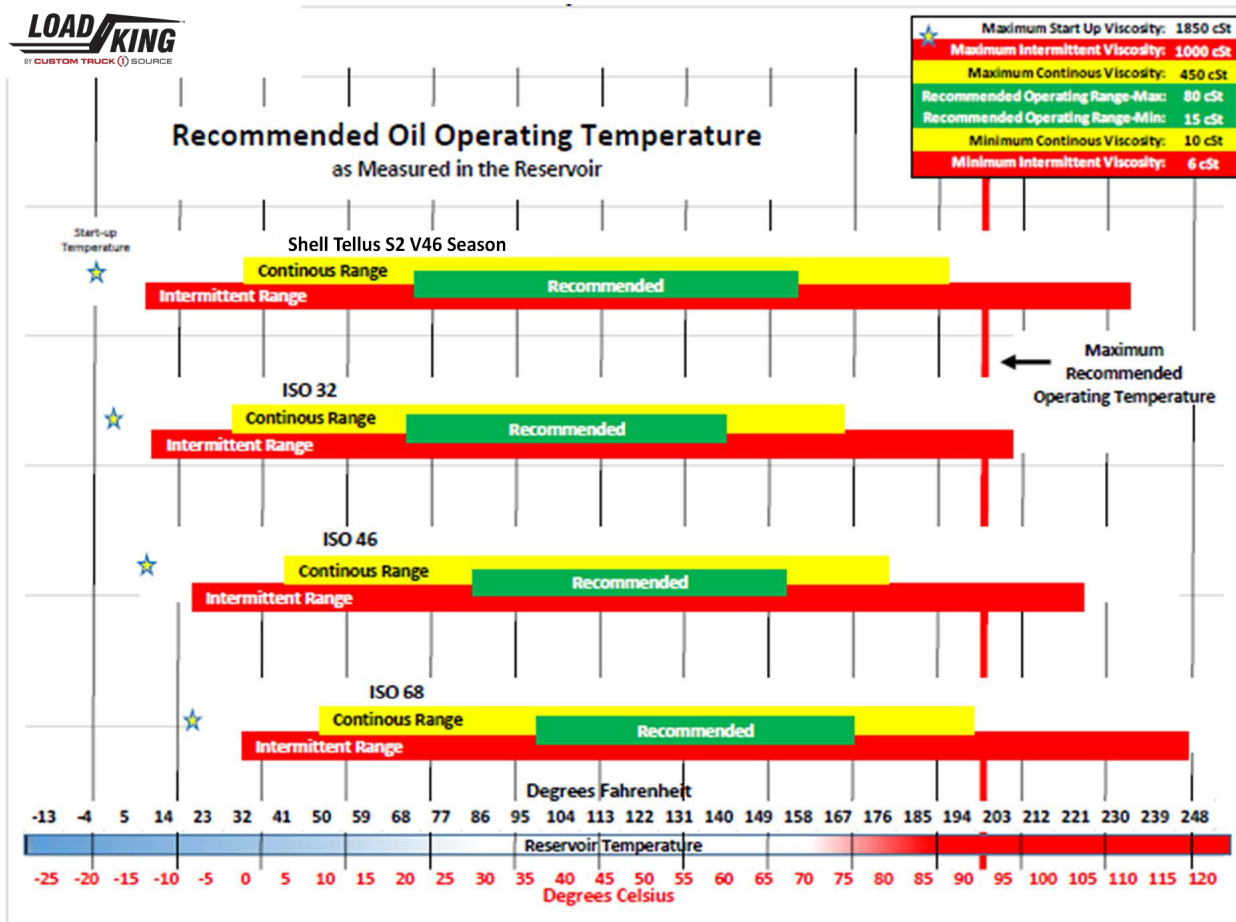

Oil Viscosity Selection Chart Color Legend

GREEN	Recommended - Component manufacturer's optimal Range
YELLOW	Continuous - Component manufacturer's limits for continuous operation
RED	Intermittent - Limited operation range

The factory-filled hydraulic oil is recommended for most operating conditions and for a wide range of oil operating temperatures as measured in the reservoir. Under certain operating temperatures and conditions (duty cycles), it may be advisable to use another fluid in order to maintain the oil viscosity in the recommended range (see [Oil Viscosity Selection Chart on page 140](#)). For startup temperatures lower than what is indicated in the chart, follow the warm up procedures in the operating manual to increase the fluid temperature and decrease potential damage. Additionally, these machines should not be operated with hydraulic reservoir temperatures in excess of 200°F (93°C). These high temperatures cause degradation of the hydraulic fluid and rubber components such as hoses and seals.

If overheating occurs, discontinue operation and:

1. Check the hydraulic fluid level.

2. Check the oil cooler for plugs or restricted air flow.
3. Check that the oil viscosity matches that recommended for the operating temperature.
4. Check pressure settings – Is a pump failing or a relief set to low?
5. Reduce the duty cycle of the machine.
6. Consult an Authorized Load King Dealer.

The following hydraulic oils are not recommended:

- Engine Oils
- Transaulic Oils
- Zinc-Free Hydraulic Oils
- Transmission Fluids

Typical Qualified Hydraulic Oils

OIL COMPANY	ISO	BRAND NAME	OIL COMPANY	ISO	BRAND NAME	
Conoco	32	Conoco DN 600 (Arctic)	Northland Products (USA)	32	Talamar 150	
		Conoco Super Hyd. 5W-20 (Multi-Viscosity)		46	Talamar 215	
		Conoco Super Hyd. 32		68	Talamar 315	
		Conoco Super Hyd. 46		46	Talamar All-Season Premium (Multi-viscosity)	
	68	Conoco Super Hyd. 68		32	Talamar Extreme 32	
Exxon Co. (USA)	32	Nuto-H 32		68	Talamar Extreme HTA 68	
	46	Nuto-H 46		Pennzoil Products Co. (USA)		AWX Multi-Viscosity
	68	Nuto-H 68			32	AW 32 Hyd. Fluids
Imperial Oil Limited (Canada)	32	Nuto H 32			46	AW 46 Hyd. Fluids
	46	Nuto H 46		68	AW 68 Hyd. Fluids	
	68	Nuto H 68	Shell Co. (USA)	23	Tellus 23	
Kendall Refining Co. (USA)	32	Kenoil R&O AW 32		32	Tellus 32	
	46	Kenoil R&O AW 46		46	Tellus 46 (XSL 9101)	
	68	Kenoil R&O AW 68	68	Tellus 68		

&!- &A Maintenance

OIL COMPANY	ISO	BRAND NAME	OIL COMPANY	ISO	BRAND NAME
Mobil Oil Corp.	32	DTE 24/DTE-13M	Texaco Inc. (USA)		Rando Oil HD A2 (5w-20)
	46	DTE 25/DTE-15M		32	Rando Oil HD 32
	68	DTE 26/DTE-16M		46	Rando Oil HD 46
		68		Rando Oil HD 68	

Hydraulic Hoses

The service life of a hose used on a mobile crane may significantly vary from the indicated lifetime of the hose from the manufacturer. The service life is influenced by a number of factors such as environment (temperature, humidity, corrosive air...) and use, duty cycles, bending cycles, abrasion, fluid etc. External unfavorable factors like heat, repeated bending under pressure etc. can reduce the lifetime significantly whereas other circumstances could allow a service life that may exceed a given period.

Inspection of Hydraulic Hoses

A daily visual check of the crane by the operator or a competent service person before starting operation shall include an inspection of the hydraulic hoses as far as possible; any traces of hydraulic oil on the crane or beneath a parked mobile crane shall lead to further investigation. The daily check might indicate irregularities and / or leakages in the hydraulic system that should be taken care of immediately. In addition to these daily checks, Load King recommends annual inspections of all hose assemblies as a part of the maintenance of the crane. Older cranes may require more frequent inspections.

Inspection Criteria:

Hydraulic hoses should be replaced if any of the following criteria are true:

- Damage on outside surface (cover) of the hose (e.g. crack, cuts, any abrasion that exposes the hose braid (reinforcement)).
- Embrittlement due to the aging of the outer surface (cracking appearing).
- Deformation that does not correspond to the original routing and shape of the hose. This criteria shall be checked in both non-pressurized and pressurized conditions and / or when bending (e.g. check for separation of hose layers, formation of blowholes, crushed points, kinks, torsioning).
- Leakage.
- Damage or deformation of hose fittings (sealing functionality affected).
- Movement between hose bulk and hose assembly (e.g. hose creeping out of fitting).
- Corrosion on a fitting that can affect the strength or function of the fitting.

Recommended Hydraulic Hose Maintenance & Replacement Schedule:

Task	Minimum Maintenance
Checking the hose lines	Annually
Recommended replacement of hose lines	Every 6 years

Recommendations for the replacement of hydraulic hose assemblies:

If replacement of hydraulic hose assemblies is required, it is recommended to use original spare parts from the OEM or hose assemblies according to the OEM specification which includes the fittings, bulk hose material and manufacturing process.

90-Day Maintenance Items

The following maintenance procedures should be done every 90 days in addition to the daily, weekly, and monthly checks:

1. Check and reset the rotation gear backlash. (See [Backlash Adjustment on page 230.](#))
2. Torque rotation gear mounting bolts. (See [Torque Specs-SAE & Metric on page 243.](#))
3. Run the unit long enough to get the hydraulic system fully warmed up and inspect thoroughly for signs of leakage due to worn hoses or loose fittings. Correct as necessary.
4. Check the load block and the downhaul weight for signs of overloading, spread side plates, elongated holes, bent tie bolts or cracks.
5. Any hooks on the load blocks or downhaul weights having a throat spread 15% wider, or twisted from the normal configuration by 10° or more, should be replaced.
6. Check all placards and load charts to ensure they are legible. If any placards are damaged or missing, they must be replaced.
7. Inspect all electrical wiring and operator aids (ATB, RCI, holding valves) for proper functioning and signs of deterioration.
8. Replace hydraulic tank breather.

Semi-Annual Maintenance Items

The following checks should be done semi-annually in addition to the daily, weekly, and monthly checks:

1. Torque the mainframe and rear outrigger mounting bolts. (See [Torque Specs- SAE & Metric on page 243.](#))
2. Check Hydraulic system pressures and adjust as necessary.
3. Inspect all visible wear pads for excessive wear or looseness.



ALL MAINTENANCE AND INSPECTION INTERVALS ARE BASED ON NORMAL USE. EXCESSIVELY HIGH DUTY CYCLE OR DUSTY, DIRTY ENVIRONMENTS WILL REQUIRE MORE FREQUENT MAINTENANCE INTERVALS. A UNIT THAT IS SUBJECTED TO PARTICULARLY ROUGH TREATMENT, OR IS FREQUENTLY OVERLOADED IS SUBJECT TO PREMATURE FAILURE.

Filters and Maintenance

DETERMINING THE CONDITION OF THE OIL

The only definite way to assure that all accumulated contaminants which will wear the pump, motors, and cylinders are removed from the hydraulic system is to drain the old oil and replace it with new. If oil did not break down or could be kept lean permanently, changing would not be necessary. The easiest way to determine the condition of oil is to obtain a sample from the system and make a visual examination.

Drain some oil from the reservoir into a clean glass container. If it smells clean and is clear, it is probably in good condition. If it has a burnt or rancid smell, or is cloudy or dark in color, the oil needs to be changed. If water appears in the bottom of the glass after it has stood awhile there may be either an opening for water to enter into the system, or the unit has been operating under conditions causing condensation. A good example of condensation from extreme temperature changes is when the unit is parked in a warm garage after being out in the cold all day.

The entry and sustained presence of water, solvents, and abrasive dirt will adversely affect the proper condition of the oil. This cause premature breakdown of viscosity, anti-foam, lubrication, and anti-rust characteristics of the oil. High operating temperatures and water will cause an increase in the oil's oxidation rate. As the oil oxidizes, sludge and varnish forming materials will be deposited in the pumps, valves, cylinders, and lines; thus increasing the rate of wear on the components.

If the oil shows that water is present, or if any other contaminates are suspected, the oil should be changed. Whenever the oil is changed, a new oil filter should always be used.

Oil contamination can also be tested for contaminate size and content, this may help in diagnosing an issue.

If the oil is drained from the unit and replaced with new oil, the unit must be run for a total of 10 hours after the change before another sample is taken for testing. This will acclimate the oil to the unit and give more conclusive results during testing.

FILTRATION

Adequate protection against oil contamination has been given to the system through filtration.

The Load King Stinger Boom Truck is equipped with a 10 micron spin on type filter to strain out particles down to 10 microns in size. (40 microns is as small as the eye can see).

All new equipment will experience some wear during initial operation. This should improve the operation of the new components after they have seated. This wear will introduce small metal particles into the system - most of which will be collected by the filter. After this breaking in process, it is mandatory that the first filter change occur. Load King recommends the filter on a new unit be changed after 100 hours of operation or 30 days of use, whichever comes first. The recommended interval of change after this initial break-in is every 90 days, or when the gauge on the filter indicates 25 PSI (RED ZONE) or above.

If the filter pressure rises above 25 PSI with the pump at 2,000 RPM it is a warning that the filter is in the bypass mode and filtration is not occurring.



NOTE: *Bypass with cold oil is normal and acceptable.*

The unit should always be allowed to gradually warm up (oil temperature above 60° F) before checking the filter bypass gauge.



The oil filter is mounted to the front of the control console. To change the return filter, shut off the power supply to the pump and unscrew the filter canister. Be careful to catch any oil spilled in a drain pan. Slightly lubricate the rubber seal on the new filter and tighten 1/3 turn past contact. See the previous Location Chart.



NOTE: *Observe all oil handling hazards*

Used oil should be recycled or reclaimed. Remember, oil is not a disposable resource and it is your responsibility to maintain sound environmental practices in regards to used oil and other fluids



IMPROPER OR INADEQUATE MAINTENANCE OF THE HYDRAULIC OIL OR OIL FILTER WILL RESULT IN PREMATURE WEAR TO VALVES, CYLINDERS, MOTORS, ETC.

SELECTING THE OIL

When buying oil, remember there is no other single factor more important to the unit's life and economic operation than the quality of the oil used. Protect the oil from losing its proper condition by rigidly following the inspection schedules and servicing of filters.

Our equipment has been quality engineered for quality oils. The finely machined cylinder and valve components cannot be expected to withstand abuse due to improper care of the hydraulic system. The most economical operation of the hydraulic system results from the use of a premium quality oil and conscientious preventative maintenance in accordance with this manual.

Load King recommends the following oil, because of its quality and availability.

RECOMMENDED OIL	AMBIENT TEMPERATURE	VISCOSITY INDEX
Shell Tellus S2 V 46	ABOVE 32°	143
Shell Tellus S2 V 32	BELOW 32°	143
Shell Tellus S2 V 22	BELOW 0°	142

Your Load King Stinger Boom Truck will have been filled with Shell Tellus S2 V 46 hydraulic oil unless otherwise specified. Different manufacturer's use chemical formulations which may not be compatible. Therefore, at a minimum, you must verify that any makeup oil added is compatible with the oil already in the system. When changing oil, if a different brand is used, the system should be flushed by cycling all cylinders at least once to their limits to insure that as much as possible of the old oil has been removed from the system.



NOTE: Observe all oil handling hazards. Used oil should be recycled or reclaimed. Remember, oil is not a disposable resource and it is your responsibility to maintain sound environmental practices in regards to used oil and other fluids



IMPROPER OR INADEQUATE MAINTENANCE OF THE HYDRAULIC OIL OR OIL FILTER WILL RESULT IN PREMATURE WEAR TO VALVES, CYLINDERS, MOTORS, ETC.

Rotation System Maintenance and Troubleshooting

Swing System

The swing system is equipped with a counterbalancing motor control. There are some basic reasons to have this system as follows:

1. To insure that the swing brake is used only as a parking brake instead of a service type brake. The brake system is not designed to slow the rotation of the unit as some people believe. It is designed to hold the boom from drifting after it is brought to a stop hydraulically. To use in any other way would cause premature wear and early failure of the brake. One counterbalance valve must pilot open the other to allow swing movement. This in turn provides a brake release signal so the brake is fully released before the boom moves.
2. The counterbalance valves used on the swing system have a 3:1 operating ratio. When used in the pilot to open mode, the sleeve portion of the cartridge may be moved in mere thousandths of an inch which provides a very precise metering control.

OPERATE MODE

When the swing control valve is shifted to swing counterclockwise, oil is directed to the valve port on the counterbalance valve which free-flows through to the motor inlet. But, the motor cannot turn because the counterbalance valve on the return side of the motor is closed and the swing brake is applied.

As pressure at the motor inlet increases, the internal shuttle valve shifts thus directing pilot pressure to release the parking brake. At the same time, this pilot pressure opens the counterbalance valve on the return side, allowing the motor to swing the boom. Return oil then flows through the other counterbalance cartridge and returns to tank through the return circuit.

The swing brake springs and the counterbalance valve are sized so that the brake fully releases at just below the counterbalance valve opening. This action prevents premature brake wear and chatter that could occur if the motor was allowed to turn through a partially applied brake.

If the boom attempts to swing faster than the supply of oil to the motor, pressure on the inlet side of the motor will decrease. This decrease in pressure will cause the counterbalance valve, at the motor outlet, to partially close and restrict return oil flow, thus decreasing the swing speed. With a given flow rate to the motor (determined by position of swing control valve spool), the counterbalance valve will automatically establish a balance between spring force trying to close the valve and pilot pressure trying to open the valve; therefore, the swing speed will be controlled at a constant rate.

NEUTRAL MODE

As the swing control valve is shifted to the neutral position; pressure at the motor inlet, counterbalance valve, and swing brake decreases. As pressure decreases, the counterbalance valve gradually closes and swing brake steadily applies bringing the boom to a smooth stop. Braking is done primarily by the counterbalance valve which prevents brake chatter that could occur if only the swing brake was used to stop the swing motion.

If pressure is lost for any reason while swinging, the counterbalance valve will fully close and the swing brake will spring apply to stop the swing motion. This is why it is important to smoothly meter the application and release of the swing control handle. The schematic on the next page will aid in following the descriptive operation of the swing system.

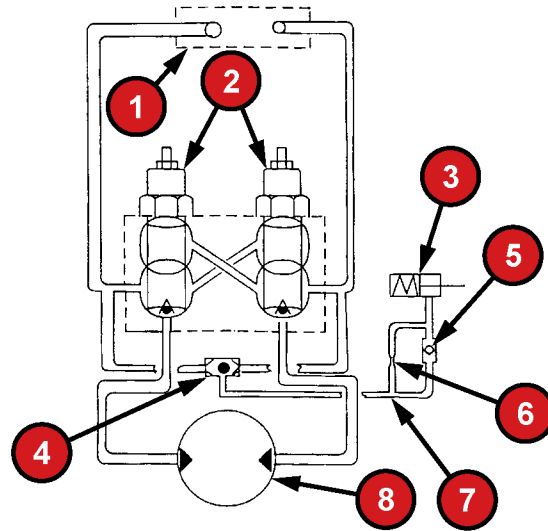

SWING SYSTEM FLOWCHART

1	Valve Section	5	Brake Release Free-Flow Check
2	Counterbalance Cartridges	6	Brake Application Restrictor Orifice
3	Swing Brake	7	Brake Release Line
4	Shuttle	8	Hydraulic Motor

Care and Maintenance of the Rotation System

Contact Load King Service Parts Department to receive overhaul information for the gearbox on the unit. Have the serial number available at time of call and the information will be sent to you.

The following steps will produce the longest possible life of the rotation bearing and rotation gearbox:

1. Load King recommends that the torque be checked on the rotation gear hold-down bolts every 90 days. This inspection should be repeated more often for Boom Trucks that see heavy cycle operation or overloading. The figures below show the location of the rotation bolts.



FAILURE TO OBSERVE THE ABOVE RECOMMENDATION COULD RESULT IN FAILURE OF ROTATION GEAR MOUNTING BOLTS AND ENDANGER THE OPERATOR AND JOB SITE PERSONNEL.

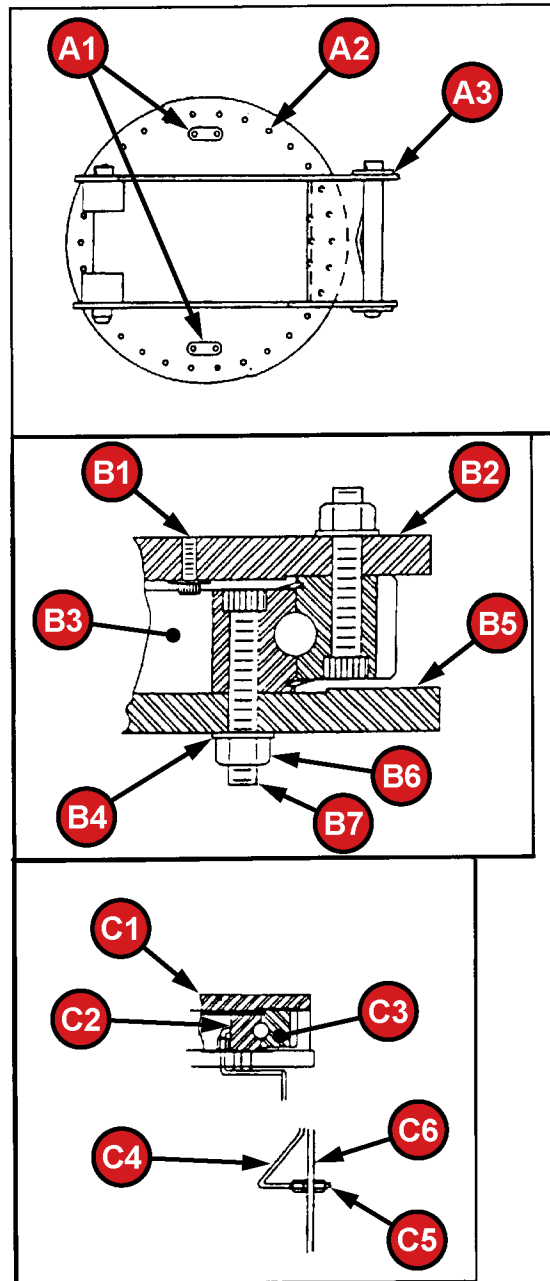

A1	Access Holes Inner Bolt Circle	B6	1-8NC Nut
A2	Outer Bolt Circle	B7	1-8NC Socket Head Bolt
A3	Turret Assembly	C1	Turret Base Plate
B1	Swing Stop Bolt	C2	Fitting in Rotation Gear (2ea - 180 degrees apart)
B2	Turret Base Plate	C3	Rotation Gear
B3	Rotation Bearing	C4	Grease Tubes
B4	Hardened Flat Washer	C5	Zerk "A" (Zerk "B" located on opposite side of turret)
B5	Mainframe Top Plte	C6	Street side of Pedestal

2. Regular periodic lubrication will increase the life and serviceability of the rotation bearing. Being a heavily loaded bearing, it's recommended that an extreme pressure grease (such as Texaco Starplex #2) be used.

Under normal operation, the rotation bearing should be greased once a week. The grease zerks are located at the streetside operator's console (or driver's side) by the inspection opening of the mainframe. There is one grease zerk for each side of the rotation bearing, 180° apart.

To properly grease this bearing, the unit should be set up with the outriggers in an operating position. Attach the grease gun to a zerk and apply 3 full shots from the grease gun. Repeat for the other grease zerk. Then rotate the boom 90° and repeat the above steps. This operation should continue through a 360° cycle of the rotation. See the previous location chart.



NOTE: *A shot is considered as one full pump stroke on a standard chassis type grease gun. It is important to not over-grease and create a wasteful run-off situation.*

Rotation Gearbox and Gear Teeth

1. The teeth of the rotation gear as well as the rotation gearbox pinion should be lubricated regularly with a good open coat lubricant (Texaco Texclad #2 or spray equivalent). The grease is purged from these teeth by the very nature of the application so close attention will produce longer tooth life. Load King recommends these teeth be lubricated once a week or more often in case of extremely heavy duty or dirty cycling applications.
2. The rotation gearbox used on the unit is a double planetary type. The gearbox is filled to the fill plug on the upper housing of the gearbox. The oil used in this gearbox should be an extreme pressure lubricant like Shell S2 G 150. It is advisable to check this fluid level about once a month, unless leakage around the gearbox is noted.
3. All swing drive gearboxes from Load King are shipped with an additive to the gear oil of 5 oz (148 ml) of ethylene glycol for cold weather protection. If gear oil in the unit is changed, Load King recommends the same amount of ethylene glycol is added to prevent freeze up of unit due to internal condensation.

The gearbox is equipped with a grease zerk (item #10) on the upper pinion bearing. Give this zerk a shot of grease about once a month to insure this bearing has adequate lubrication (see following illustration).



NOTE: *A shot is considered as one full pump stroke on a standard chassis type grease gun. It is important to not over-grease and create a wasteful run-off situation.*



DO NOT OVER-LUBRICATE THIS BEARING OR THE GREASE WILL BE PUMPED OUT OF THE UPPER PINION SEAL.

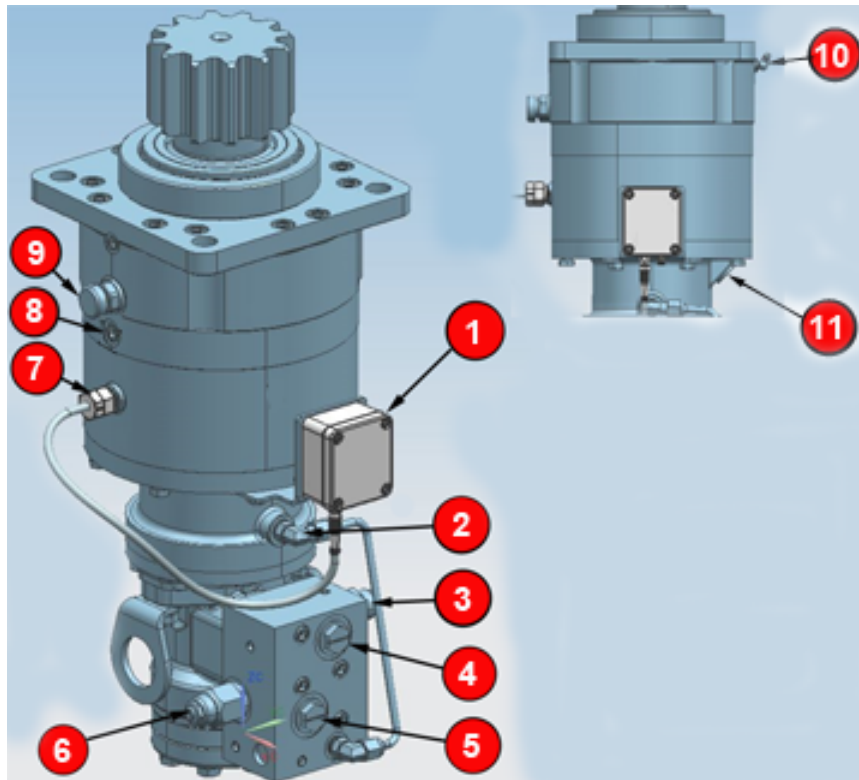

Swing Drive Gearbox & Motor

1	Conditioning Box	7	Swing Sensor (WAD)
2	Brake Pressure	8	Oil Level Plug
3	Cartridge Valve	9	Breather & Oil Fill Location
4	Motor Pressure Port	10	Grease Zerk
5	Motor Pressure Port	11	Oil Drain Port
6	Cartridge Valve		

Swing (WAD/ISS) Sensor Check & Replacement Procedure

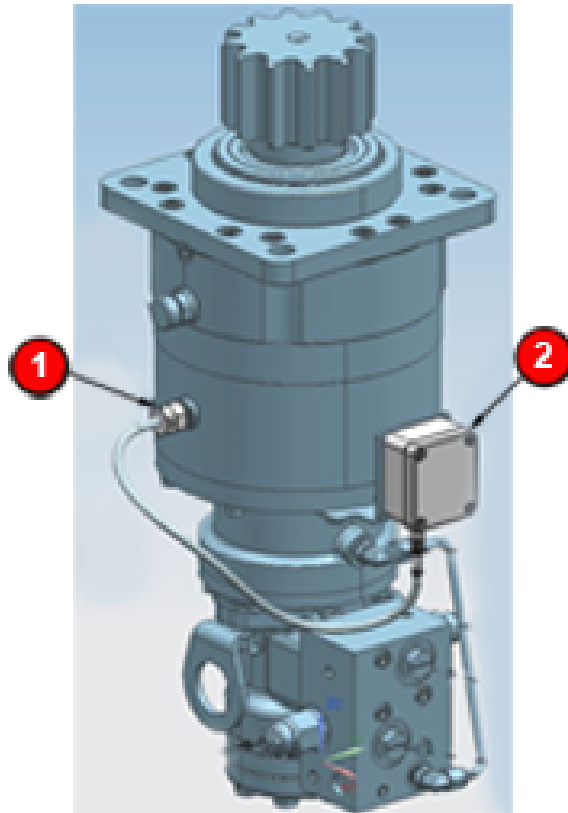

Swing Gearbox & Motor

1. Swing (WAD) Sensor
2. Conditioning Box

Operation into an unintended work zone may result if the Operator Programmable Alarms do not function as programmed and an operator is relying on them to alert him/her when approaching the unintended work zone.

Precheck procedure to verify Swing Work Area Definition (WAD/ISS) Sensor if functioning properly:

1. Set the boom in the boom rest and align to the zero location as shown in Fig. 1. Record the CURRENT SWING ANGLE displayed on the RCI display.

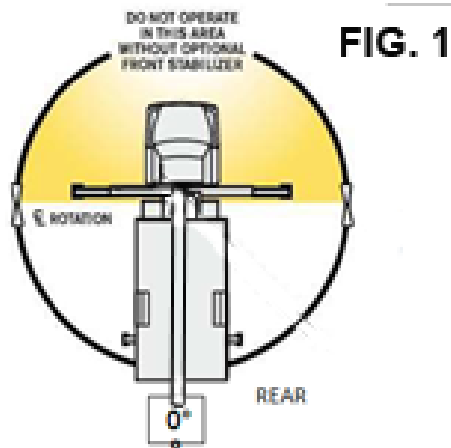

2. Raise the boom until the boom angle is approximately 40°.
3. Rotate the boom slowly and smoothly to the 90° position as shown in Fig. 2.

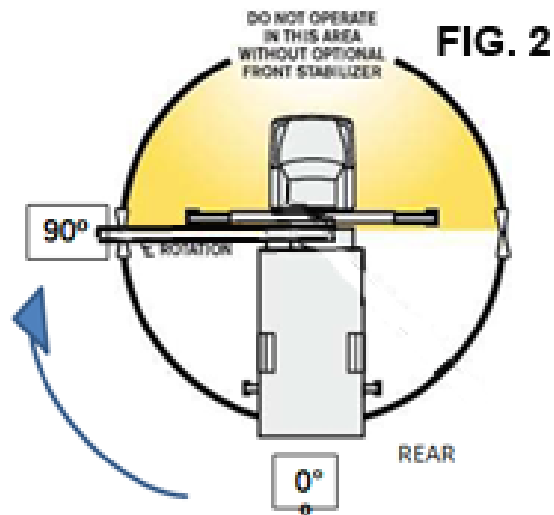

4. Swing the boom counterclockwise approximately 20° and stop abruptly.
5. Pause approximately 5 seconds.
6. Repeat steps 4 and 5 until the boom is at the 270° position as shown in Fig. 3. This completes one cycle.

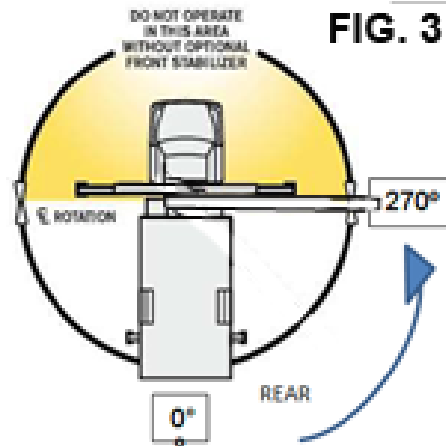

7. Repeat Steps 3 thru 6 nine times, for a total of ten cycles.
8. Set the boom in the boom rest and align to the zero location as shown in Fig. 1. Record the CURRENT SWING ANGLE displayed on the RCI display.
9. If the CURRENT SWING ANGLE readings recorded in Steps 1 or 8 are zero, The WAD/ISS is functioning as intended.
If the CURRENT SWING ANGLE reading recorded in Steps 1 or 8 is anything other than zero, the WAD/ISS is not functioning as intended. Proceed to instructions for replacing the WAD sensor. Part No. T145537.
Until unit passes the test procedure, unit may only be operated with the LEFT SWING and RIGHT SWING on the RCI display set to the "OFF" position.

WAD Sensor Replacement Procedure

1. Set crane on outriggers. Select an open area without obstructions where the retracted boom can be rotated from the 0° position either right or left toward the 90° or 270° positions as shown in Fig. 4.

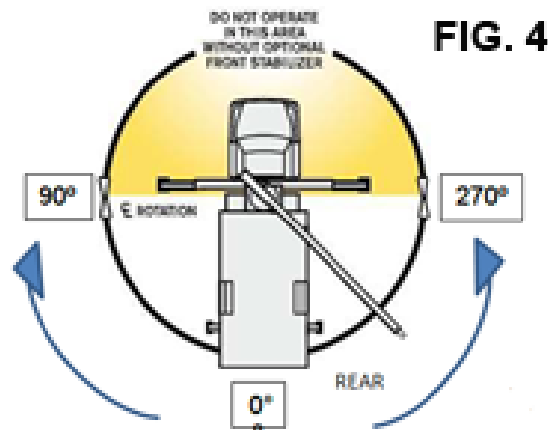

2. Place the boom in the boom rest (stowed position).
3. Turn off the power to the crane.

4. Remove covers to gain access to swing-drive and pinion using a socket wrench.
5. Manually unthread and disconnect the sensor cable from the conditioning box as shown in Fig. 5.

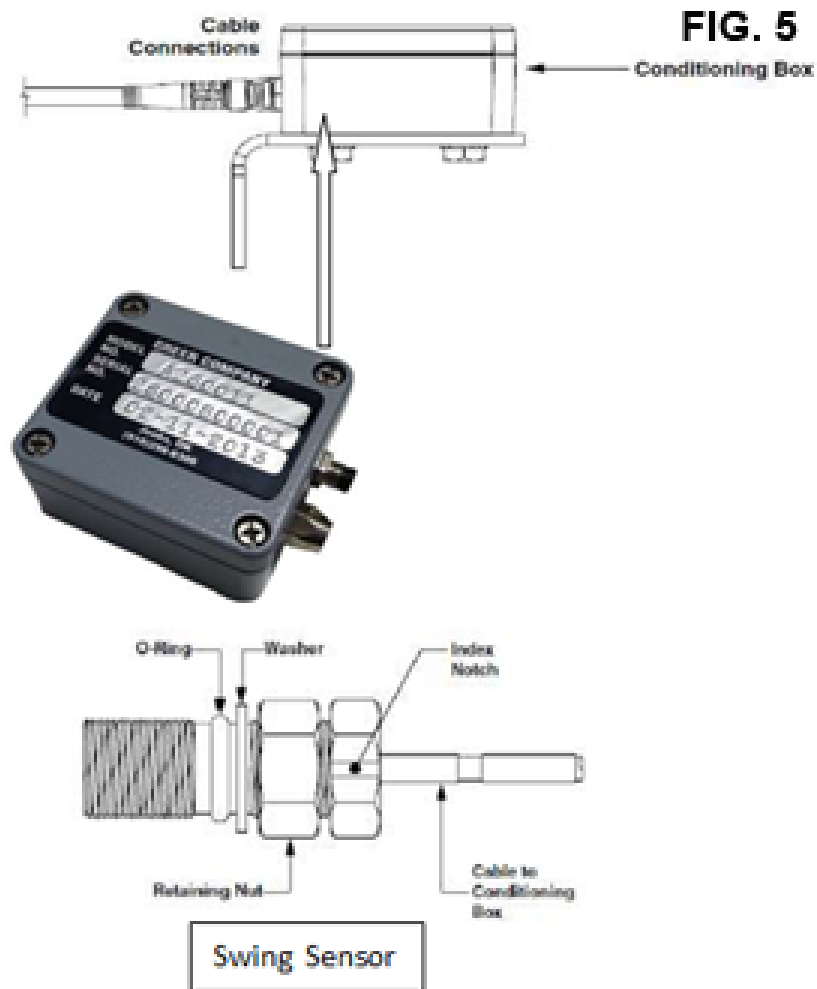

Conditioning Box & Swing Sensor

6. Loosen the sensor retaining nut using a 3/4" open-end wrench.
7. Unthread and disconnect the sensor from the swing drive housing using a 3/4" open-end wrench.
8. Mount dial indicator as shown in Fig. 6 using 1/2" diameter bell-type indicator tip.

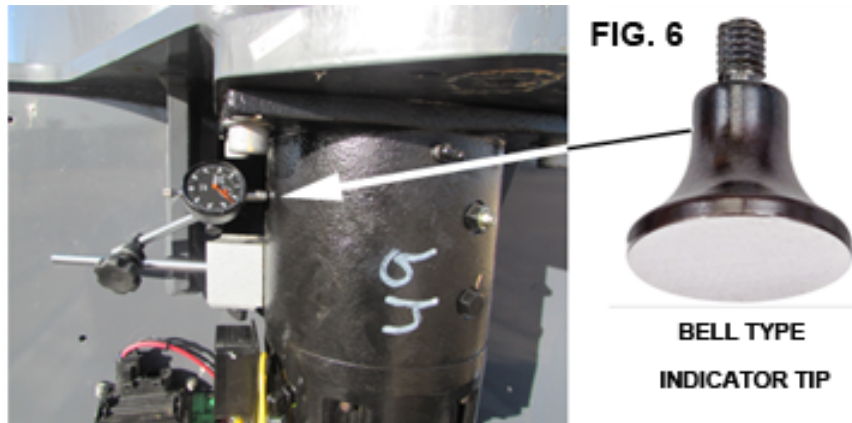

Dial Indicator & Bell Type Indicator Tip

9. Re-power the crane.
10. Raise boom out of boom rest to approximately 40°.
11. Rotate swing drive at least one full revolution of the output pinion gear while watching dial indicator to determine lowest reading on indicator. Note the lowest reading.
12. Rotate the swing drive to the position of the lowest reading.
13. Remove the dial indicator.
14. Install the new WAD Sensor, Part No. T145537, by inserting the threaded end of the sensor into the sensor port of the swing drive (see Fig. 7) by hand, thread it clockwise until the end of the sensor contact the gear inside the swing drive housing. Do not force the sensor any past this point, as you may damage the sensor.

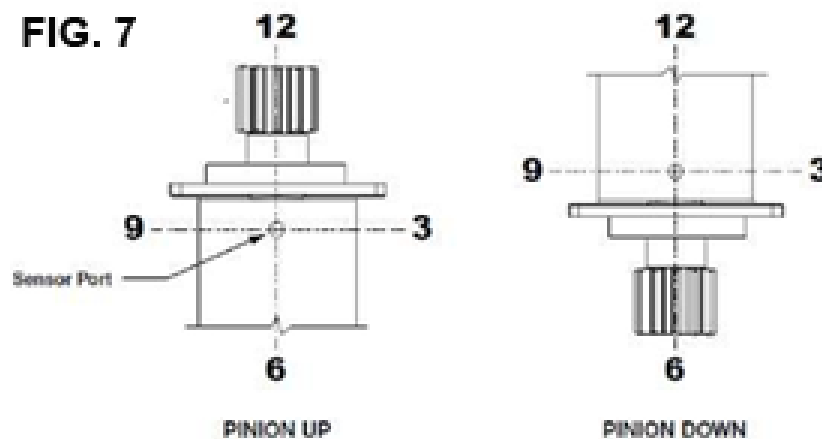

Swing Drive Port

15. Note the location of the index notch on the sensor. Rotate the sensor counterclockwise exactly 1/2 turn.
16. Note the position of the index notch on the sensor and continue to rotate counterclockwise until the index notch reaches the 'three o'clock' or 'nine o'clock' position, no more than 1 full turn from location of sensor at the end of Step 12.
17. Tighten the sensor retaining nut using 3/4" open-end wrench.

&!- &A Maintenance

18. Manually insert the sensor cable into the conditioning box and thread clockwise.
19. Replace covers for swing-drive and pinion using socket wrench.
20. Calibrate per Swing Sensor Setup instructions in the RCI manual.
21. Repeat the Precheck procedure Steps 1 thru 8.

Winch Lubrication

RECOMMENDED PLANETARY GEAR OIL

Field experience, supported by engineering endurance tests, indicates the use of the proper gear oil and a program of regular preventative maintenance will help provide extended gear train life and reliable hoist brake performance. The information below is intended to assist in determining which lubricant is best suited to your application.

Please refer to the winch manufacturer's documentation (included with your manual pack) for specific recommendations and specifications of the proper oil to use in your winch.

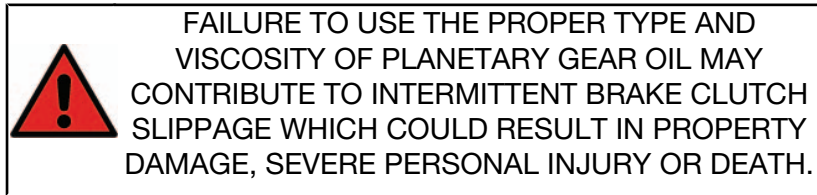

SOME GEAR LUBRICANTS CONTAIN LARGE AMOUNTS OF EP (EXTREME PRESSURE) AND ANTI-FRICTION ADDITIVES WHICH MAY CONTRIBUTE TO BRAKE CLUTCH SLIPPAGE OR DAMAGE TO BRAKE FRICTION DISCS OR SEALS. OIL VISCOSITY WITH REGARD TO AMBIENT TEMPERATURE IS ALSO CRITICAL TO RELIABLE BRAKE CLUTCH OPERATION. TESTS INDICATE THAT EXCESSIVELY HEAVY OR THICK GEAR OIL MAY CONTRIBUTE TO INTERMITTENT BRAKE CLUTCH SLIPPAGE. MAKE CERTAIN THAT THE GEAR OIL VISCOSITY USED IN YOUR HOIST IS CORRECT FOR YOUR PREVAILING AMBIENT TEMPERATURE.

Unless otherwise specified, it is recommended that the gear oil be changed after the first (100) hours or two (2) months of machine operation, then every one thousand (1,000) hours or six (6) months, whichever occurs first. The gear oil should also be changed whenever the ambient temperature changes significantly and an oil from a different temperature range would be more appropriate.

A warm-up procedure is recommended at each startup and is essential at ambient temperatures below +40°F (4°C).

The prime mover should be run at its lowest recommended RPM with the hydraulic hoist control valve in neutral allowing sufficient time to warm up the system. The hoist should then be operated at low speeds. Raise and lower, several times to prime all lines with warm hydraulic oil and to circulate gear lubricant through the planetary gear sets.

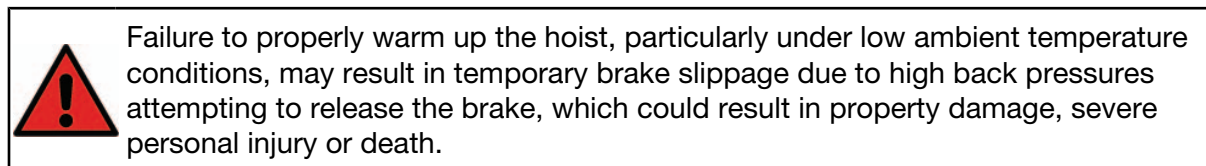

Wire Rope Lubrication

New wire rope is lubricated during manufacturing, but this lubrication is only adequate for initial storage and the early stage of operation. To prevent the damaging effects of corrosion and to reduce wear, the wire rope must be lubricated at regular intervals.

The lubrication interval and the type of lubricant to be used depend on the type of wire rope, the severity of duty, and the type of corrosive elements the wire rope is subjected to. General guidelines are printed in your maintenance manual. Contact the nearest wire rope dealer for specific lubrication recommendations.

The wire rope must be properly protected at all times; therefore, the gaps between the strands and wires must be filled with lubricant to provide a complete seal. Refer to maintenance manual for proper lubrication methods.

Storage

Storage

Machines being placed in storage must be adequately protected from deterioration during the period of idleness. This will ensure that they can be restored to active service with a minimum effort.

Before removing this hydraulic crane from service for extended periods, it should be prepared for storage as prescribed in the following paragraphs. In general, three (3) major components must undergo preparation. These are the Machine Proper, the Engine and the Transmission. The specific procedure to be followed depends upon the expected period of storage.

SHORT TERM STORAGE - 30 DAYS OR LESS

Short term storage requires minimal preparation.

The MACHINE should be thoroughly cleaned, lubricated in accordance with Section 4, and painted surfaces retouched where the paint has deteriorated. exposed portions of all hydraulic cylinders should be coated with multipurpose grease. Coat unpainted metal surfaces with multipurpose grease after removing any rust accumulations.

The ENGINE should be prepared as prescribed in the topic [“Engine Storage” on page 168](#).

The TRANSMISSION should be prepared as prescribed in the topic [“Transmission Storage” on page 172](#).

LONG TERM STORAGE - 30 DAYS OR MORE

Long term storage requires greater preparation than short term storage and must be undertaken with greater care.

The MACHINE should be prepared as follows:

1. Perform the short term machine storage preparation, making certain that all points with grease fittings are liberally lubricated.
2. Drain and refill the swing reducer, winch(es), axle differentials, planetary hubs and the hydraulic reservoir. Refer to page Group 4 when servicing the reservoir.
3. Distribute the new hydraulic fluid to all parts of the system by operating all functions.
4. Clean and tape the battery cables after removing and storing the battery.
5. Coat the external ring gear of the swing bearing with open gear lubricant.
6. Block wheels so any rubber tires are not in contact with concrete. Cover tires if exposed to sunlight.
7. Fill the hydraulic reservoir to the top AFTER THE MACHINE IS PARKED IN ITS STORAGE SPOT.
8. Coat wire rope with lubricant.

9. Coat exposed cylinder rods with grease.

The ENGINE should be prepared as prescribed in the topic [“Engine Storage” on page 168](#).

The TRANSMISSION should be prepared as prescribed in the topic [“Transmission Storage” on page 172](#).

Restoration to Service

Refer to [“Restoring Engine to Service” on page 171](#), and [“Restoring Transmission to Service” on page 173](#), for the procedures required to restore these components to service.

Remove the MACHINE from storage via the following procedure:

1. Remove preservative lubricants from all surfaces.
2. Check all fluid levels, adding or draining as required.
3. Lubricate the machine according to Group 4, making certain that all points with grease fittings are lubricated.
4. Make a thorough visual inspection of the entire machine, placing special emphasis on the condition of all hydraulic hoses.

Engine Storage

PREPARING ENGINE FOR STORAGE

When an engine is to be stored or removed from operation for a period of time, special precautions should be taken to protect the interior and exterior of the engine, transmission, and other parts from rust accumulation and corrosion. The parts requiring attention and the recommended preparations are given below.

It will be necessary to remove all rust or corrosion completely from any exposed part before applying a rust preventive compound. Therefore, it is recommended that the engine be processed for storage as soon as possible after removal from operation.

The engine should be stored in a building which is dry and can be heated during the winter months. Moisture absorbing chemicals are available commercially for use when excessive dampness prevails in the storage area.

TEMPORARY STORAGE (30 DAYS OR LESS)

To protect an engine for a temporary period of time proceed as follows:

1. Drain the engine crankcase.
2. Fill the crankcase to the proper level with the recommended viscosity and grade of oil.
3. Fill the fuel tank with the recommended grade of fuel oil. Operate the engine for two minutes at 1200 rpm and no load.



NOTE: *Do not drain the fuel system or the crankcase after this run.*

4. Check the air cleaner and service it, if necessary as outlined under Air System.
5. If freezing weather is expected during the storage period, add a high boiling point type antifreeze solution in accordance with the manufacturer's recommendations. Drain the raw water system and leave the drain cocks open.
6. Clean the entire exterior of the engine (except the electrical system) with fuel oil and dry it with air.
7. Seal all of the engine openings. The material used for this purpose must be waterproof, vapor proof and possess sufficient physical strength to resist puncture and damage from the expansion of entrapped air.

An engine prepared in this manner can be returned to service in a short time by removing the seals at the engine openings, checking the engine coolant, fuel oil, lubricating oil, transmission, and priming the raw water pump, if used.

EXTENDED STORAGE (30 DAYS OR MORE)

When an engine is to be removed from operation for an extended period of time, prepare it as follows:

1. Drain and thoroughly flush the cooling system with clean, soft water.
2. Refill the cooling system with clean, soft water.

3. Add a rust inhibitor to the cooling system (refer to Group 4, "Corrosion Inhibitor").
4. Remove, check and recondition the injectors, if necessary, to make sure they will be ready to operate when the engine is restored to service.
5. Reinstall the injectors in the engine, time them, and adjust the valve clearance.
6. Circulate the coolant through the entire system by operating the engine until normal operating temperature is reached (160° F. to 185° F).
7. Stop the engine.
8. Remove the drain plug and completely drain the engine crankcase. Reinstall and tighten the drain plug. Install new lubricating oil filter elements and gaskets.
9. Fill the crankcase to the proper level with a 30- weight preservative lubricating oil MIL-L-21260, Grade 2 (P10), or equivalent.
10. Drain the engine fuel tank.
11. Refill the fuel tank with enough rust preventive fuel oil such as Americal Oil Diesel Run-In Fuel (LH 4089), Mobil 4Y17, or equivalent, to enable the engine to operate 10 minutes.
12. Drain the fuel filter and strainer. Remove the retaining bolts, shells and elements. Discard the used elements and gaskets. Wash the shells in clean fuel oil and insert new elements. Fill the cavity between the element and shell about two-thirds full of the same rust preventive compound as used in the fuel tank and reinstall the shell.
13. Operate the engine for 5 minutes to circulate the rust preventive throughout the engine.
14. Refer to page Group 4 and service the air cleaner.
15. With an all-purpose grease such as Shell Alvania No. 2, or equivalent, lubricate the clutch throwout bearing, clutch pilot bearing, drive shaft main bearing, clutch release shaft, and the outboard bearings (if so equipped).
16. Remove the inspection hole cover on the clutch housing and lubricate the clutch release lever and link pins with a hand oiler. Avoid getting oil on the clutch facing.
17. Apply a non-friction rust preventive compound, to all exposed parts. If it is convenient, apply the rust preventive compound to the engine flywheel. If not, disengage the clutch mechanism to prevent the clutch disc from sticking to the flywheel.



Do not apply oil, grease or any wax base compound to the flywheel. The cast iron will absorb these substances which can "sweat" out during operation and cause the clutch to slip.

18. Drain the engine cooling system (tag cap).
19. The oil may be drained from the engine crankcase if so desired. If the oil is drained, reinstall and tighten the drain plug (tag cap).
20. Remove and clean the battery and battery cables with a baking soda solution and rinse them with fresh water. Store the battery in a cool (never below 32°F.) dry place. Keep the battery fully charged .
21. Insert heavy paper strips between the pulleys and belts to prevent sticking.

&!- &A Maintenance

22. Seal all of the openings in the engine, including the exhaust outlet, with moisture resistant tape. Use cardboard, plywood or metal covers where practical.
23. Clean and dry the exterior painted surfaces of the engine. Spray the surfaces with a suitable liquid automobile body wax, a synthetic resin varnish or a rust preventive compound.
24. Cover the engine with a good weather-resistant tarpaulin or other cover if it must be stored outdoors. A clear plastic cover is recommended for indoor storage.

The stored engine should be inspected periodically. If there are any indications of rust or corrosion, corrective steps must be taken to prevent damage to the engine parts. Perform a complete inspection at the end of one year and apply additional treatment as required.

Restoring Engine to Service

1. Remove the valve rocker cover(s) and pour at least one-half gallon of oil, of the same grade as used in the crankcase, over the rocker arms and push rods.
2. Reinstall the valve rocker cover(s).
3. Remove the covers and tape from all of the openings of the engine, fuel tank, and electrical equipment. Do not overlook the exhaust outlet.
4. Wash the exterior of the engine with fuel oil to remove the rust preventive.
5. Remove the rust preventive from the flywheel.
6. Remove the paper strips from between the pulleys and the belts.
7. Check the crankcase oil level. Fill the crankcase to the proper level with the heavy-duty lubricating oil recommended under Lubricating Oil Specifications.
8. Fill the fuel tank with the fuel specified under Diesel Fuel Oil Specifications.
9. Close all of the drain cocks and fill the engine cooling system with clean soft water and a rust inhibitor. If the engine is to be exposed to freezing temperatures, add a high boiling point type antifreeze solution to the cooling system (the antifreeze contains a rust inhibitor).
10. Install and connect the battery.
11. Service the air cleaner as outlined under Air System.
12. Prepare the generator for starting.
13. Remove the inspection hole cover and inspect the clutch release lever and link pins and the bearing ends of the clutch release shaft. Apply engine oil sparingly, if necessary to these areas.
14. After all of the preparations have been completed, start the engine. The small amount of rust preventive compound which remains in the fuel system will cause a smoky exhaust for a few minutes.



NOTE: *Before subjecting the engine to a load or high speed, it is advisable to check the engine tune-up.*

Transmission storage

PRESERVATIVE SELECTION

It is recommended that the highest viscosity monograde lubricant available be used for the anticipated ambient temperature. Typically this will be a Cat TO-4 qualified lubricant. When large swings in ambient temperature are probable J20 C, D multigrades are recommended. Multigrade lubricants should be applied at the lower viscosity rating for the prevailing ambient temperature i.e. a 10W20 should be used where a 10W monograde is used. If a C-4 multigrade is used in place of J20 lubricant it is recommended that the viscosity be no more than 10 points, i.e. 10W20.

STORAGE

If the transmission is to be stored in excess of 60 days before being put into service, the units should be completely filled with the lubricant specified above and stored in a dry area.

It is also recommended that at least every 30 days all flanges be rotated by not less than two complete turns to insure complete lubrication of the seals.

Restoring Transmission to Service

1. Drain oil.
2. Install a new oil filter element(s).
3. Refill transmission with hydraulic transmission fluid to proper level.

Chrome Cylinder Rod Storage

Hard chrome plating is primarily applied to steel cylinder rods for its wear resistant properties, although it does provide considerable corrosion resistance as well. Once the chrome-plated rod is assembled into a cylinder and put into service, the hydraulic fluid on the surface of the rod provides all the corrosion resistance required for the rod during its life cycle. As a cylinder cycles, hydraulic fluid is driven into any surface cracks that exist in the chrome plate. When these cracks are filled with hydraulic fluid, moisture or corrosive fluids can not penetrate the cracks. However, some machining and cleaning operations can negatively impact the future corrosion resistance of chrome-plated shafting. For example, additives such as chlorine, sulfur, and sodium found in Extreme Pressure (EP) coolants and some washing solutions are known rust accelerates and can strip chrome plating from the base metal. Cleaning processes, such as phosphate washing are also known to be detrimental to the corrosion resistance of hard chrome plated shafting.

If the rod is not periodically cycled and is subject to a corrosive environment, moisture and oxygen can work its way down through the chrome layer and begin to corrode the base metal. Brand new equipment may be stored outside for a considerable period of time at the equipment dealership before it is sold. During these times, a protective barrier must be applied to the exposed cylinder rod. This protective barrier will preserve the integrity of the chrome plating by preventing the elements of corrosion from getting to the metal substrate.

Cylinders should be stored in the retracted position, if at all possible. The steps outline below cover the procedures to be followed for Protecting New Equipment from corrosion if it must be stored in the extended position:

1. Position the equipment as it will be stored and identify all the exposed portions of the chrome plated cylinder rods.
2. Clean any dirt and dust from the exposed portions of the cylinder rods using a dry cloth or a cloth which has been dampened with an appropriate solvent. Do not use caustics or acids.
3. Apply a thin coating of ¹“Ferro-Kote 5856-BF” to the exposed surfaces of the chrome plated cylinder rods. The Ferro-Kote may be thinned using a 40% Kerosene or No. 1 fuel oil mixture.
4. Inspect the cylinder rod surfaces and reapply at three to six month intervals.
5. If the equipment is to be moved and then stored again for an extended period of time or if the cylinder is cycled, steps 1 through 4 should be repeated for all cylinder rods that were exposed.

For the protection of Older Equipment that is to be stored, the procedure outlined above can be used, but greater attention to cleaning the exposed portions of each cylinder rod is required. Solvent applied with plastic or copper wool can be used, but abrasives such as sandpaper should never be used to clean the exposed surfaces of the cylinder rod. If surface damage to the chrome plate is discovered, the frequency of corrosion barrier applications should be increased.

¹ Ferro-Kote 5856-BF is a product of Quaker Chemical Company, Conshohocken, PA 19428



NOTE: *Caution must be used when cleaning equipment in service with high pressure washes. Soaps or chemicals containing chlorines or other corrosive elements should be avoided. Cylinders should be cleaned in a retracted position as not to expose rods to the chemicals. Cylinders should be cycled immediately following the wash. If rods are to be stored in the extended position, refer to steps 1-4 above.*

Page Intentionally Blank

Pumps and Function Speeds

The pumps used on the Load King Stinger Series Boom Truck are fixed/positive displacement of the rotary vane type. To produce the proper amount of flow to run the functions at full speed, the pump shaft must be turning at 2,300 RPM.

The required speed for the pump is very important when testing the unit speeds and checking or handling maximum loads. Remember also that pump speed and engine speed are not always the same. For instance, if the truck transmission is equipped with a 115% PTO, the required engine speed to achieve the desired pump RPM would be approximately 2,000 RPM. It is very important that you know what the ratio of the PTO is on the unit being serviced.

When involved in troubleshooting a unit that is believed to have slow functions, it is important to know the pump is receiving the proper RPM and how much flow to expect from the pump. The following charts will allow you to accurately test the flow of the pump, as well as determine what is the proper speed of the functions on the unit.

SYSTEM FLOWS

GPM @ 1,200 RPM	GPM @ 2,300 RPM	FUNCTION
21 GPM	36 GPM	WINCH
11 GPM	20 GPM	BOOM
5 GPM	11 GPM	SWING

FUNCTION SPEEDS

The following chart is a list of the speeds you can expect from the Load King Stinger Boom Truck. All speeds are noted as being one (1) complete cycle. For instance, the swing time is for one 370° rotation, (stop to stop) at the full 2,300 RPM - and all times are in seconds.

MODEL	25-92M
SWING	50
EXTEND	80
RETRACT	45
BOOM UP	50
BOOM DOWN	32
WINCH (Normal Speed)	129 FPM
WINCH (Combined Flow Hi Speed)	198 FPM



NOTE: Winch speeds based on 2,300 pump RPM and 3rd wrap on the winch drum.

Page Intentionally Blank

Troubleshooting

CONDITION	POSSIBLE CAUSE
No response to any control	PTO not engaged Low hydraulic oil supply Broken hydraulic pressure line Defective pump
Slow operation	Pump not operating at proper speed Low hydraulic oil supply Relief setting too low Worn pump, motor, or cylinder Plugged filter Valve spools not fully opening Cold oil
Excessive noise during operation	Low oil supply causing pump cavitation Suction line gate valve closed Relief settings too low Excessive load Suction line kinked, causes pump cavitation Hydraulic tube vibrating
No response, slow or erratic operation of winch function	Defective counterbalance valve Brake locked, sprage clutch defective Relief settings too low Gears damaged or locked in gear case Defective drive motor
No response, slow or erratic operation of swing function	Swing brake locked on Rotation drive motor worn Gears damaged or locked in rotation mechanism
Boom will not hold position with controls in neutral and load suspended	Defective counterbalance in lift cylinder Defective counterbalance in extension cylinder Defective cylinder packings
Outrigger drifts down during roading or drifts up under load	Defective pilot operated check cartridge Cylinder seals worn

This Manual does not contain any information for the truck. Please adhere to the following safety practices and information when performing any maintenance or repair on the Load King Truck Crane. If in doubt, contact your local Load King dealer for assistance.

Winch System Maintenance and Troubleshooting

Winch Maintenance and Repair

The Load King Stinger Boom Truck is equipped with a power drum type winch. It is equipped with a spring-applied, pressure-released brake. Operation of this system requires a counterbalance valve to insure that the brake is totally released when winching down, with or without a load. When winching in the up direction, the input shaft turns through a sprag clutch in the freewheel direction, which does not require the brake to be released.

Winching up the load is quite simple. To winch in, we simply supply the winch motor with enough pressure to lift the load. When pressure is removed, the sprag clutch engages the brake automatically to prevent the load from dropping.

Winching down is a little more complicated. There are two systems that prevent the winch from back driving and allowing a load to drop.

1. **Winch brake** is a spring applied, pressure released brake that requires internal pressure to release. The sprag clutch connects the brake to the winch drum. Being a special one way clutch, it allows the winch to free-wheel in the up direction, and lock in the winch down direction.
2. **Counterbalance valve** is a special valve blocking the flow of oil at the motor. TO winch down, the motor is pressurized and through a pilot signal passage it releases the brake and opens the counterbalance which allows oil to flow through the motor. It takes more pressure to open the counterbalance than to release the brake, so the brake is totally released before the winch rotates.



NOTE: *Incorporated into the counterbalance is an in-line check which allows the motor case to drain while preventing winch pressure from entering the motor case.*

To test the counterbalance valve, tee a gauge to the brake release line at the winch. The winch should begin to move down at no lower pressure than 300- 400 PSI.

If the counterbalance system is working properly, the winch will make no attempt to turn until this 300-400 PSI is reached. Contact Load King Service Department to receive overhaul information for the winch on the unit. Have the serial number available at time of call and the information will be sent to you.

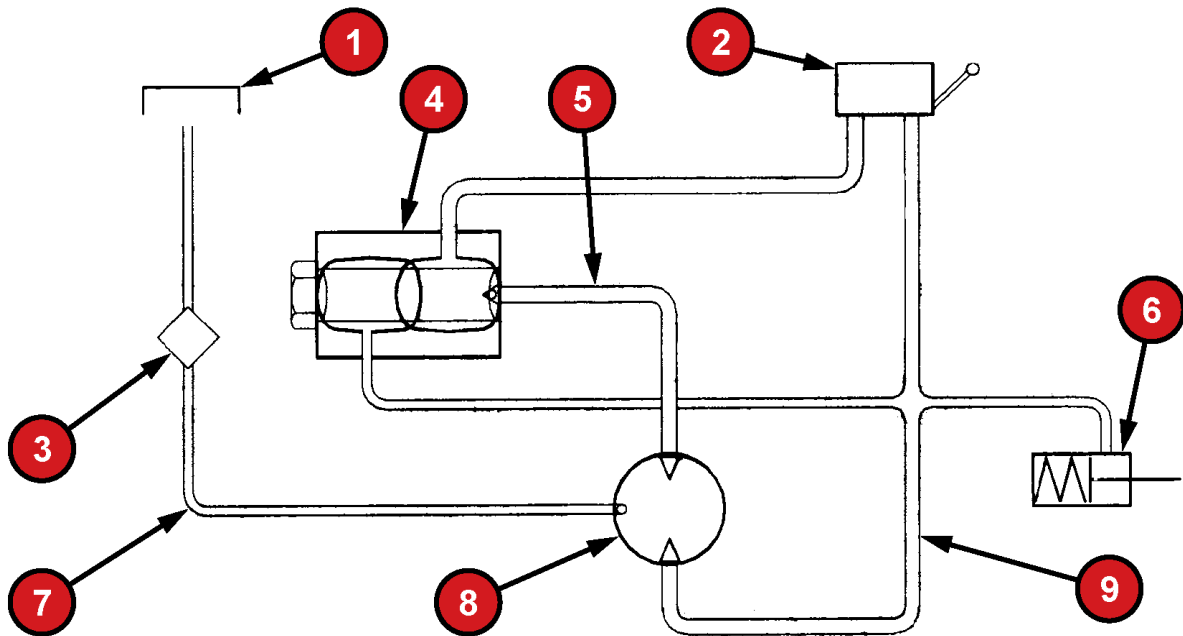

1	Hydraulic Tank	6	Winch Brake
2	Valve Section	7	Case Drain
3	Return Filter	8	Winch Motor
4	Counterbalance Valve	9	Winch Down Line
5	Winch Up Line		

Burst of Speed Winch Function

The Load King Stinger Boom Truck is equipped with a burst of speed winch system as standard equipment. This is controlled by a push button on the winch control at each operator's console. When the high speed button is pushed to the down position, oil from the 20 GPM side of the pump is pushed into the mainstream of the winch oil. This makes the speed of the winch almost double. When the button is released, the flow to the boom control valve is again directed to the boom function.

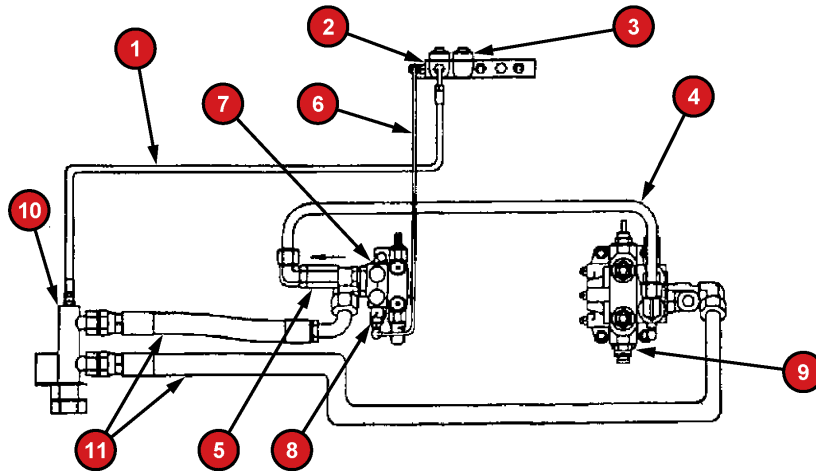

1	Unloader Tank Line	7	Control Valve Inlet
2	Winch Unloader Valve	8	Anti-Void
3	ATB Unloader Valve	9	Winch Control Valve
4	Regenerative Oil to Winch	10	Return Manifold
5	One-Way Check	11	Control Valve Return Lines
6	Regenerative Pilot Line		



NOTE: *The boom functions will drastically slow or cease to operate when the high speed winch is engaged. This is normal as most or all of the boom circuit oil is now going to the winch.*

Note in the picture above that the winch and boom control valves are linked together by a tube at the inlets. In this tube, there is a one way check valve to insure the winch oil is not allowed to make its way into the boom circuit. The arrow on the check valve should be pointing away from the boom control valve.

The boom circuit oil is directed or bypassed by a ported anti-void cartridge in the inlet section. If the pilot signal is contained in the anti-void, the winch speed will stay low. If the pilot signal is allowed to escape through the unloader valve, it creates a pressure drop in the spring chamber, which allows the anti-void to open. When this happens, boom circuit oil is allowed to go to the inlet of the winch valve, where it is added to the oil from the winch section of the hydraulic pump. If the high speed circuit fails to operate, check the following:

1. Check all electrical connections to make sure power is getting to the winch unloader valve solenoid.
2. If the solenoid coil is getting power, check with a screwdriver on the end of the solenoid to see if it is energized. (The metal screwdriver should be magnetically attracted to the end of the solenoid shaft if the coil is working properly.)
3. If the coil is working, the solenoid may be stuck and should be cleaned or replaced.
4. If the high speed fails to function after replacing the solenoid, the anti-void valve is stuck and will need to be disassembled and cleaned.

If, on the other hand, the high speed circuit is on constantly, check the following:

1. Check that the unloader solenoid coil is deenergized (off).
2. Check that the solenoid is not stuck open. Remove the tank line and plug both the hose and valve. If normal operation is restored, the solenoid is stuck open.
3. The anti-void valve is bypassing internally.

Page Intentionally Blank

Hydraulic System Description

The hydraulic system on the Load King Stinger Boom Truck is an open center system. The open-center means that any time the hydraulic pump is running and the control valves are in the neutral position, oil is going into the inlet of the control valves and through the open center of the valve and back to the tank. The oil is at low pressure because an opening to the tank exists in the return line. If a spool is moved and the oil is diverted to an enclosed function line, the pressure of the pump will rise to meet the load requirement. As long as the control valve handle is held open and the load is unchanged (constant) , this working pressure will be sustained. The pump is a fixed displacement pump; it produces a given volume each revolution. If there was no system relief when the cylinder or actuator bottoms out, the pump would produce enough pressure to either destroy itself, the main pressure line, or another component. For this reason, there are system reliefs incorporated. The proper working order and settings of these reliefs is extremely important. Operation of open center hydraulics is illustrated on this page.

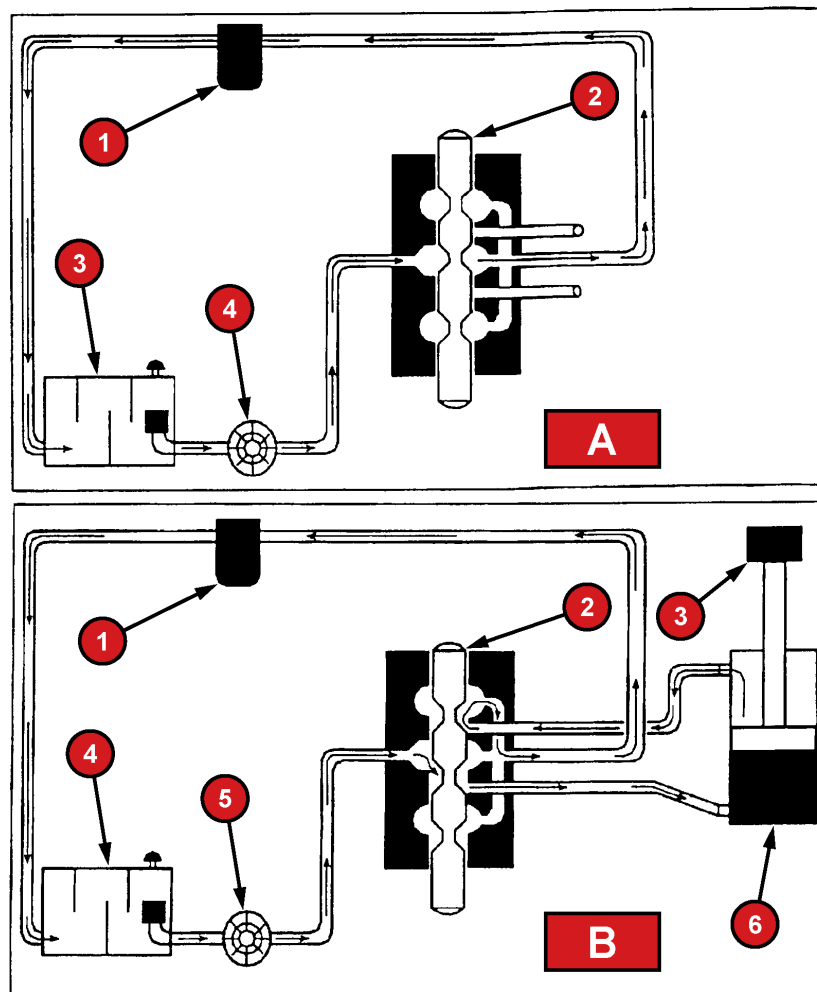

A	Open Center Hydraulics/Neutral	B1	Filter
A1	Filter	B2	Open Center Valve
A2	Open Center Valve	B3	Load
A3	Tank	B4	Tank
A4	Pump	B5	Pump
B	Open Center Hydraulics/Operate	B6	Actuator

Control Valves and Pressures

The relief pressure settings on the Load King Stinger Boom Truck are very important. They protect the system components from being overpressured by allowing oil above the main relief setting to be vented to the tank. If this does not happen on a fixed displacement system, it could cause serious damage to hoses, pumps, and other components in the system.

The chart below summarizes the valves used on the Load King Stinger Boom Truck by function and configuration. It also gives the rated operating pressures required for the boom, swing, and winch system. All pressures are +/- 50 psi.

VALVE SPECIFICATIONS AND PRESSURE SETTINGS

FUNCTION	CONFIGURATION	PRESSURE
WINCH	OPEN CENTER/OPEN PORT (MOTOR)	2800PSI
BOOM / OUTRIGGER	OPEN CENTER/CLOSED PORT	3000 PSI
SWING	OPEN CENTER/OPEN PORT (MOTOR)	1500 PSI

The system pressures can be checked by installing a pressure reading device on the hydraulic test pressure ports located at the right-side console.

The relief used on the control valve is a pilot operated type. Oil enters through the orifice in the end of the piston and is trapped against the seat of the pilot poppet. As long as the relief valve has the signal trapped and isolated from the tank, the main relief will remain closed. However, if the spring force holding the pilot poppet closed is overcome, oil can get out faster than it can get in through the orifice in the piston poppet. This causes a pressure drop inside the cartridge and the relief piston opens, unloading the oil to the tank. Any malfunction of this relief is usually caused by dirt or foreign material caught on the sealing surfaces.

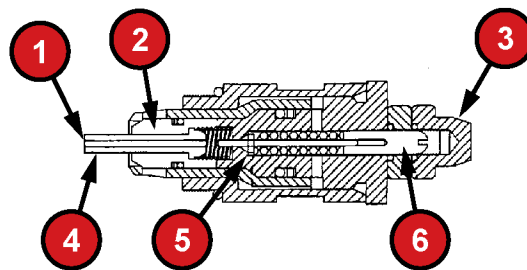

1	Oil Inlet Orifice	4	Piston Poppet
2	Relief Piston	5	Pilot Poppet
3	Acorn Nut	6	Adjustment Screw

The reliefs are factory set and should not be tampered with unless poor performance is experienced. Any relief which has been removed for inspection, cleaning, or replacement

must be adjusted after installation. The figure above is a cutaway view of a typical relief found in the boom, winch, and swing system of the Load King Stinger Boom Truck.

INSPECTION AND REPAIR

Clean all parts with solvent and dry with compressed air. Make sure the orifice in the piston is open. Examine seat on the pilot poppet and make sure it is free of grooves or ridges. If these conditions are present, the entire relief cartridge must be replaced. All seating surfaces should be smooth and free of nicks, scratches, or grooves. Examine o-rings and back-up rings for any signs of damage. Replace damaged or faulty parts. All moving parts should slide freely with only seal friction present. If possible, remove minor nicks or scratches in poppets or poppet seats by lapping with a fine grade of lapping compound. Clean poppets thoroughly after this procedure. If operating difficulties indicate that pilot poppet is leaking or sticking, remove internal parts of pilot section and follow same procedure as above. After inspecting and cleaning, immerse all parts in hydraulic oil and reassemble. Torque pilot section in housing to 40 ft.lbs. and recheck system pressure.

RELIEF VALVE SPECIFICATIONS

PROBLEM	CAUSE	REMEDY
NO PRESSURE	POPPET STUCK DIRT IN POPPET	CHECK FOR WEAR CLEAN AS REQUIRED
PRESSURE ERRATIC	POPPET SEAT DAMAGE POPPET STICKING	REPLACE DAMAGED PARTS CLEAN CARTRIDGE
PRESSURE SETTING NOT CORRECT	INTERNAL WEAR ADJUSTER LOOSE	CLEAN OR REPLACE ADJUST RELIEF
LEAKS	DAMAGE O-RINGS OR WORN PARTS	REPLACE WORN PARTS OR RESEAL

PROCEDURE FOR ADJUSTING BOOM AND OUTRIGGER RELIEFS

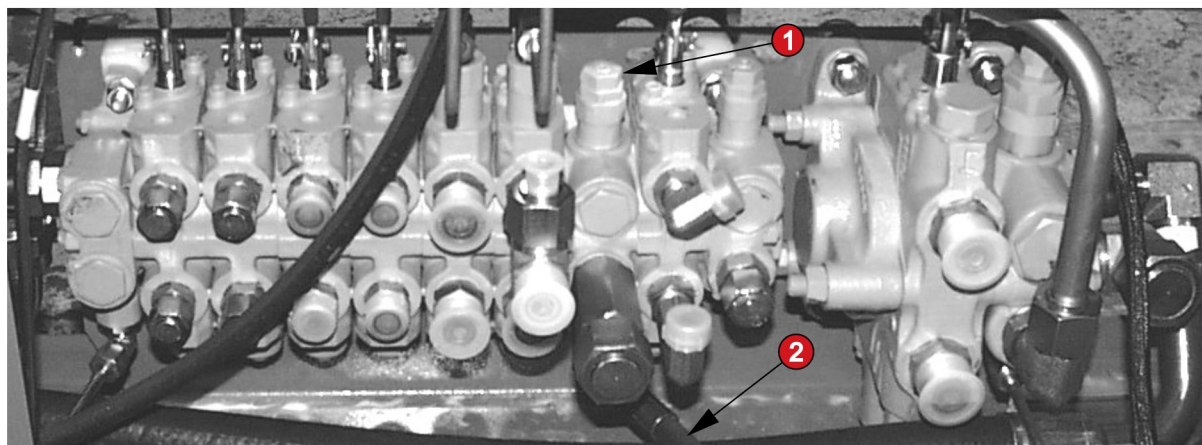

1	Boom/Outrigger adjust	2	To Test Pressure Port
---	-----------------------	---	-----------------------



3 BOOM / OUTRIGGER TEST PRESSURE PORT

The system reliefs should be set only when the oil in the hydraulic system is warm or at operating temperature.

1. With the control levers in neutral position, raise pump RPM to 2,300.
2. Slowly retract the boom extension cylinder until it reaches the end of the stroke and forces the system pressure upward to relief pressure.

LEAVE ALL OTHER CONTROL LEVERS IN THE NEUTRAL POSITION.

3. Check the reading on the test gauge. See pressure table for proper settings.



NOTE: *Move the lever to the neutral position immediately after taking the pressure reading to avoid excessive heat.*

4. Make proper adjustments to relief by turning the relief adjustment clockwise for more pressure and counter clockwise for less pressure. Be sure to retighten the jam nut to 10 ft.lbs. and install the acorn nut.

PROCEDURE FOR ADJUSTING SWING RELIEFS

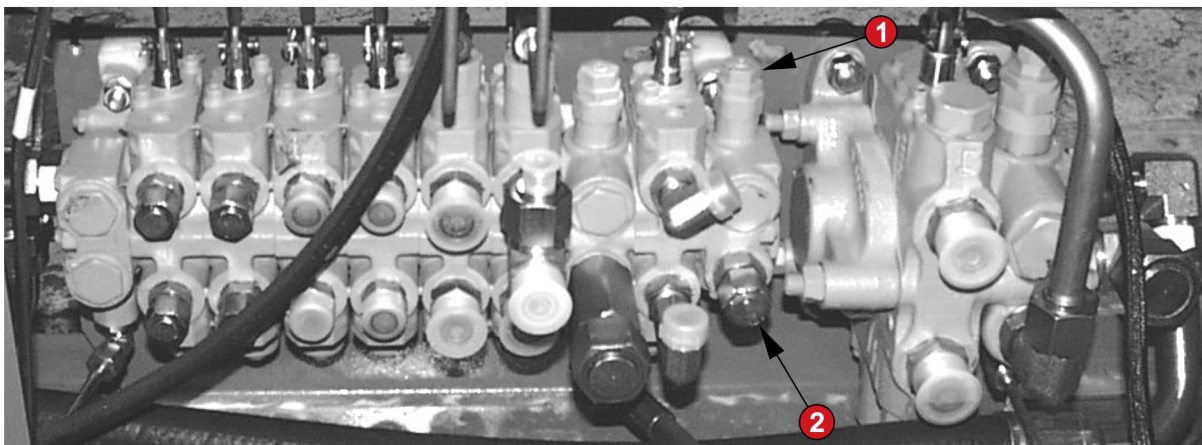

1 Swing Adjust	2 To Test Pressure Port
----------------	-------------------------



3 Swing Test Pressure Port

1. Stop the engine, remove the brake release hose at the rotation gearbox and attach a 0 - 3,000 PSI pressure gauge at the end of the hose. The brake release fitting does not need to be capped.
2. Start engine and run the pump at 2,300 rpm and slowly move the swing lever to full travel in either direction. The spring applied swing brake will stall the swing motor and cause the hydraulic system to go over relief. Look at the pressure gauge; see previous pressure table for proper setting.



NOTE: Move the lever to the neutral position immediately after taking the pressure reading to avoid excessive heat.

3. Make proper adjustments by turning the adjusting screw clockwise for more pressure and counterclockwise for less. Be sure to torque the jam nut to 10 ft.lbs and reinstall the acorn nut.

PROCEDURE FOR ADJUSTING THE WINCH RELIEF

The system relief should be set only when the oil in the hydraulic system is warm or at operating temperature.

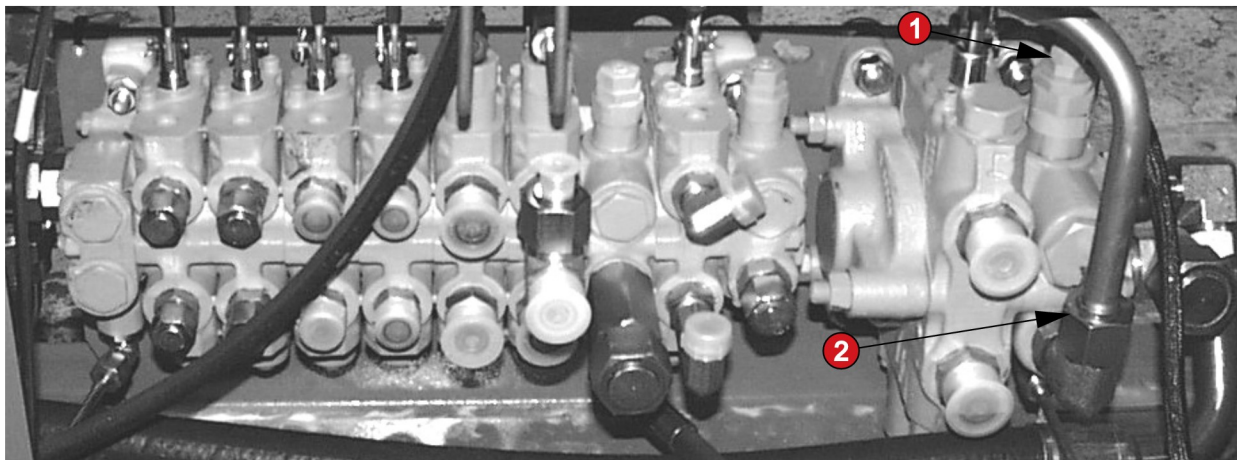

1 WINCH ADJUST

2 TO TEST PRESSURE PORT



3 WINCH TEST PRESSURE PORT

1. Remove and cap the brake release hose from the motor side of the winch.
2. With the winch at 2,300 RPM, hold the winch control lever in the down position until the system goes over the relief.

LEAVE ALL OTHER CONTROL LEVERS IN THE NEUTRAL POSITION.

3. Check the reading at the system test receptacle.



NOTE: *Move the lever to the neutral position immediately after taking the pressure reading to avoid excessive heat.*

4. Make proper adjustments to relief by turning the relief adjustment clockwise for more pressure and counterclockwise for less pressure. Be sure to retighten the jam nut to 10 ft.lbs. and install the acorn nut.

Outrigger and Cylinder Maintenance and Troubleshooting

Outrigger Position Sensors

If your crane is equipped with Outrigger Position Sensors-the rear outrigger box will contain (2) two proximity sensors for determining the location of each outrigger beam at full extension. Each sensor has an air gap to maintain to operate properly and send signals to the RCI. When each rear outrigger beam is fully extended a green light on the operator's Outrigger control box and will illuminate for both the left side and right side. Visually inspect sensors for damage, the condition of related wiring harness connections and dirt / debris that could inhibit the sensor signal or proper air gap.

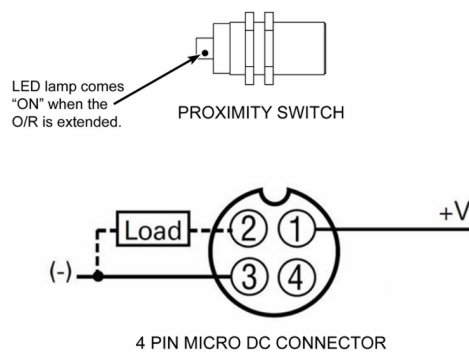

SENSOR CHARACTERISTICS & SETTING	
OUTPUT TYPE	NORMALLY CLOSED
SENSING RANGE	15 MM
MINIMUM OPERATING VOLTAGE	6 VDC
MAXIMUM OPERATING VOLTAGE	48 VOLTS
MINIMUM OPERATING TEMPERATURE	-40C
MAXIMUM OPERATING TEMPERATURE	+70C
MINIMUM LOAD CURRENT	200 MA
AIR GAP SETTING	0.12" (3.2 mm)

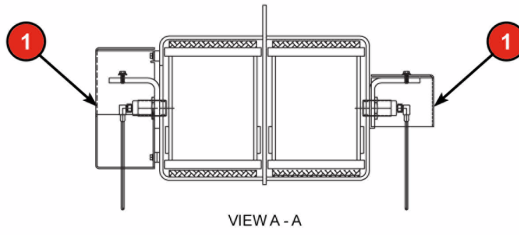

VIEW A - A

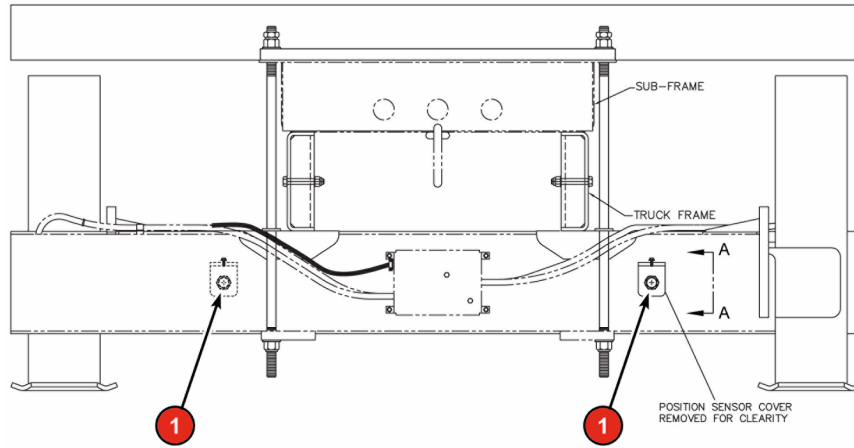

1. Proximity Sensor- Outrigger Position

Lift Cylinder

HOW TO ANALYZE TOPPING PERFORMANCE

The lift cylinder should hold up the boom and load with a minimal amount of drop-off. The cylinder is equipped with a counterbalance type holding cartridge in the base of the cylinder.



DO NOT REMOVE THE CARTRIDGE IN THE BASE END OF THE TOPPING WITHOUT THE BOOM BEING UNLOADED AND IN A SUPPORTED CONDITION. REMOVING THE CARTRIDGE WITH THE BOOM IN AN UNSUPPORTED CONDITION WILL CAUSE THE BOOM TO DROP INSTANTLY AND UNCONTROLLABLY.



TRAPPED PRESSURE IN CYLINDER CAN FORCEFULLY EJECT CARTRIDGE. MAKE SURE PRESSURE IS RELIEVED BEFORE REMOVING A CARTRIDGE. NEVER STAND BEHIND A CARTRIDGE WHILE REMOVING IT.

To test the cylinder for holding, the following procedure should be used:



NOTE: *With the outriggers extended, mark each outrigger leg. These marks should be checked at the end of the test procedure below to determine if any outrigger is the cause of the movement noted.*

With the boom fully retracted and at a 50-60° angle, attach a weight equivalent to the rated load and raise the load 2 feet off the ground. Accurately measure and record the distance from the ground. Shut off the engine and move the control levers to release the hydraulic pressure trapped in the hoses. The load should not drop more than 1/2" in 10 minutes. If it drops more than the amount allowed, the following troubleshooting steps should be performed:



NOTE: To prevent thermal contraction giving an inaccurate result, any cylinder drift test should be performed using ambient temperature hydraulic oil.

A leaking cylinder will generally fall into 2 categories:

1. External leaks (usually found around the base of the cylinder).
 - A. RCI system sense line hose and fittings.
 - B. End casting welds.
 - C. Cartridge O-Rings.
 - D. Cross-drilled passages and plugs.

2. Internal leaks (bypassing within the cylinder or holding cartridge). There are two things that must be checked in order to isolate the source of the leakage:
 - A. Holding cartridge:

Attach a weight equivalent to the rated load and raise the boom 2-3 inches off the boom rest. Remove both topping hoses at the control valve. Oil coming from the boom-up hose indicates a bypass at the counterbalance cartridge. Replace or clean the cartridge. Boom must be unloaded and supported before cartridge is removed.
 - B. Piston bypassing from base side to rod side:

If oil comes out of the boom-down hose while still engaged in the same test, the cylinder is bypassing internally and will require internal repairs.

LIFT CYLINDER REMOVAL

Perform the following steps to remove the lift cylinder:

1. Fully retract and lower the boom onto the boom rest. Disengage the PTO and stop engine. Actuate topping lever in both directions to release trapped pressure.
2. Tag and disconnect the hydraulic lines from the lift cylinder.



Hydraulic oil may be under pressure. Loosen fittings very slowly to prevent injury.

- These should be plugged or capped to prevent any fluid loss or slippery surfaces around the work area - also to prevent contamination from entering the hydraulic system. Plug the resulting open ports of the cylinder to prevent the loss of fluid.
3. Lift against the rod end of the lift cylinder with a hoist or another crane and remove the rod end pin.
 4. With the cylinder balanced in a choker strap, that is attached to a suitable hoist or other type of lifting equipment, support the cylinder and remove the pin in the cylinder base. It weighs approximately 5000 lbs. Remove the cylinder, taking precautions to prevent scratching the paint finish.

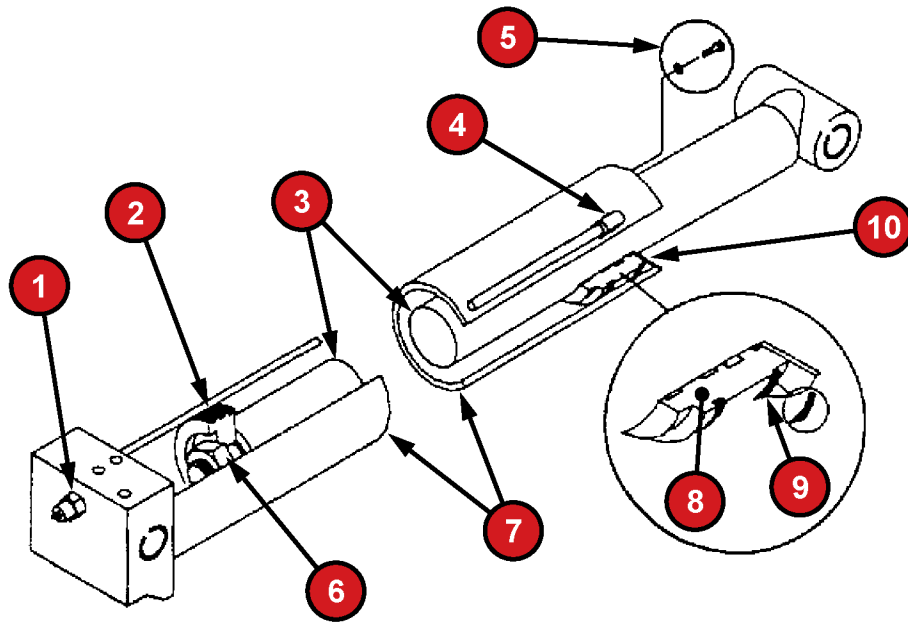

1	CARTRIDGE	6	PISTON NUT
2	PISTON	7	BARREL
3	ROD	8	END GLAND
4	BYPASS ORIFICE	9	RETAINER RING
5	RETAINER PLATE BOLTS	10	RETAINER PLATE

LIFT CYLINDER OVERHAUL PROCEDURE

Contact Load King Service Department to receive overhaul information for the cylinder on the unit. Have the cylinder part number, located on the barrel, available at time of call and the information will be sent to you.

Outrigger Cylinder

OUTRIGGER TWO-WAY CHECK SYSTEM

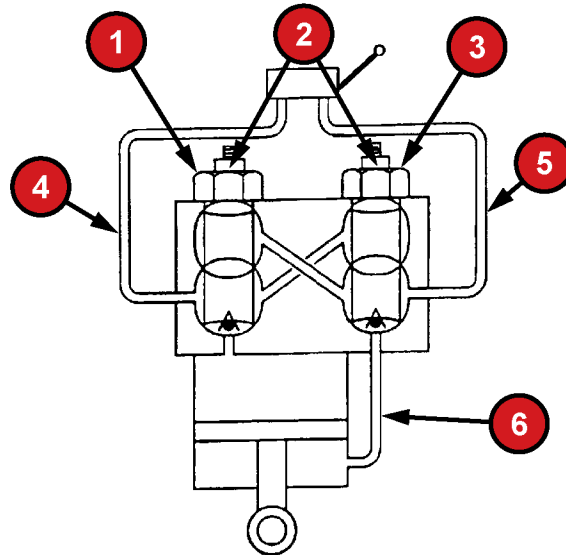

1	Outrigger Holding Cartridge - LOAD	4	Extend Tube
2	Manual Release	5	Retract Tube
3	Outrigger Holding Cartridge - STOW	6	Side Tube

OUTRIGGER TWO-WAY PILOT TO OPEN CHECK SYSTEM

LOCATED: On each outrigger cylinder.

FUNCTION: Locks outrigger in up position for roading, and down for crane or operation. Requires internal pilot pressure to operate in either direction.

INFORMATION: All outrigger cartridges are the same on Load King Boom Trucks.



DO NOT REMOVE CARTRIDGES WITHOUT SUPPORTING THE OUTRIGGERS IN AN UNLOADED CONDITION. CARTRIDGES DO NOT BLEED OFF PRESSURE BY REMOVING SLOWLY. THEY CAN EJECT FORCEFULLY IF THE CYLINDER IS PRESSURIZED. NEVER STAND IN LINE WITH CARTRIDGE WHILE

The main reason for outrigger servicing is leaking. There are two types of leaks: External and internal.

External leaks may or may not cause the outrigger to drift depending on the source of the leak. External leaks can usually be located by visually inspecting the cylinder while it is at full system pressure fully stroked in one direction or the other.

Some things to check might be:

1. Steel lines and fittings.

2. Welds (Base to cylinder barrel).
3. End gland of cylinder.
4. Cartridge O-Ring.

Internal leaks are more difficult to find and almost without exception require cylinder removal. Three items must be checked to isolate the leak:

1. The load holding cartridge.
2. Stop engine. Activate outrigger control handle to relieve trapped pressure. Disconnect extend port hose at valve.
3. If oil runs out of the extend port, the cartridge is bypassing and must be replaced.

TO CHECK LOAD HOLDING CARTRIDGE:

1. Raise truck off ground until tires are clear. If possible, apply maximum payload to flatbed
2. Stop engine. Activate outrigger control handle to relieve trapped pressure. Disconnect extend port hose at valve.
3. If oil runs out of the extend port, the cartridge is bypassing and must be replaced.

TO CHECK STOW HOLDING CARTRIDGE:

1. Fully retract cylinder.
2. Devise a means of externally trying to extend the cylinder. (Porta-Power or Block & Tackle).
3. Disconnect retract port hose at valve. If oil runs out of the cylinder, retract pressure port. The stow holding cartridge is bypassing and must be replaced.

TO CHECK CYLINDER PISTON:

1. Fully extend cylinder.
2. Remove retract cartridge. Use caution, as there will be trapped pressure behind this cartridge.
3. Pressurize extend port to full system pressure.
4. If oil runs out of retract cartridge bore, piston is bypassing and cylinder must be serviced.

REMOVAL & DISASSEMBLY OF MAIN OUTRIGGERS

1. Extend the outrigger until the shoe just touches the ground.
2. Remove the snap rings from the link pin at the outrigger leg. The pin should drive out easily if the leg is properly positioned. If the pin does not drive out easily, reposition the leg so the pin is not loaded. Allow the links to swing down after the pin is removed.



USE A HOIST OR OTHER SUITABLE LIFTING DEVICE TO SUPPORT THE LINKS. DO NOT LET LINKS "FREE SWING". DAMAGE OR INJURY COULD RESULT.

3. Disconnect the outrigger hoses, after marking for later reinstallation. Cap hoses and fittings on cylinder.

4. Attach a choker strap on the lower side of the link pin boss. Drive a wedge between the inner and outer legs to help hold the inner leg in place when the upper pivot pin is removed.



DO NOT DRIVE THE WEDGE TO THE POINT OF BOWING THE METAL IN THE LEG.

Take up the slack in the strap with a hoist.

5. Remove the snap ring from the upper pivot pin, and with a brass or dead blow hammer and a drift, drive the upper pin out of the outrigger housing and mainframe bracket.
6. Raise the hoist until the leg is balanced, then lay the leg on the floor with the link pivot boss turned down (upside down). Block up under the outrigger leg until the outrigger shoe clears the floor.
7. Remove the snap rings for the outrigger shoe pin and drive the pin out with a drift. Remove the shoe and pin.
8. With the assistance of a hoist, pull the cylinder out of the top end of the outrigger housings.
9. Remove the inner leg and check the weldments thoroughly for any sign of damage, bending, or welds cracking. Check the wear pads for damage. If pads are worn and have excessive clearance, they should be shimmed or replaced.
10. Move the cylinder to overhaul bench.

REASSEMBLY & INSTALLATION OF MAIN OUTRIGGERS

1. Apply a thin film of brush-type anti-seize lubricant (rust inhibitor) to outrigger wear pads before assembly.
2. Using the proper bolts, attach the top upper and lower wear pads. (Note: It's a good idea to use Loctite on these bolts to prevent them from loosening and coming out.) Using a hoist, slide the inner and outer legs together, and install the upper bottom wear pad.
3. Have the cylinder extended to approximately mid-stroke. Insert the cylinder into the outrigger housings and align the cylinder rod eye with the pin hole and shoe holes. Apply a thin coat of antiseize lubricant (rust inhibitor) to the pin before insertion. Install pin and snap rings.
4. Using the upper pivot pin as a pilot, line up cylinder base pin hole with upper pivot hole in the inner leg. After holes are aligned, drive the wedge between the inner and outer legs again to help maintain alignment.



DO NOT DRIVE THE WEDGE TO THE POINT OF BOWING THE METAL IN THE LEG.

5. Apply a thin coat of anti-seize lubricant (rust inhibitor) to pin before installation.

6. Using the choker strap and hoist, pin the upper leg to the mainframe bracket. Lower the leg until the links align with the hole in the outrigger leg boss.
7. Install the pin through the links and outrigger boss and install the snap rings.
8. Connect the outrigger hoses. Cycle cylinder several times to full stroke to remove any air in the cylinder.

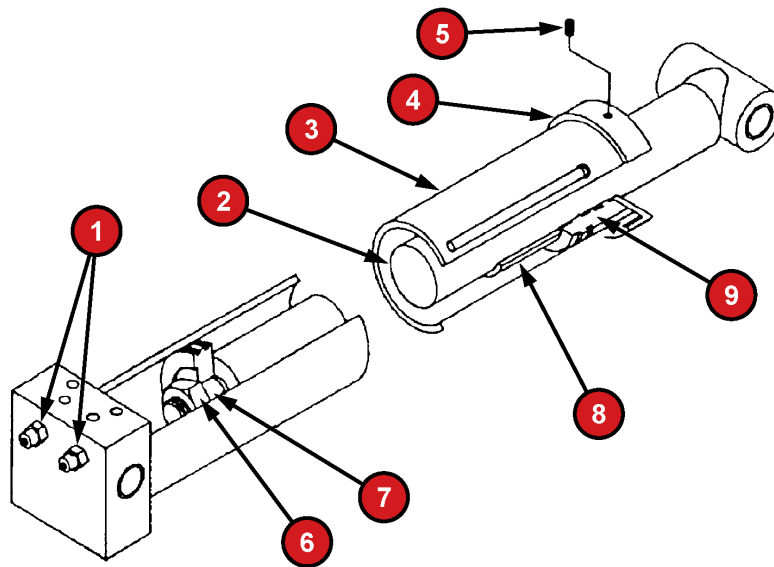

1	Holding Cartridge	6	Piston Nut
2	Rod	7	Piston
3	Barrel	8	Spacer
4	Thread Cap	9	Gland
5	Set Screw		

REMOVAL & DISASSEMBLY OF AUXILIARY OUTRIGGERS

1. Either work with the rear outriggers over a pit or raise the rear of the truck so that there is at least 36" of clearance from the bottom of the outrigger shoes.
2. Extend outrigger leg 1" and shut off power. Move control handles to relieve trapped pressure.
3. Tag and disconnect cylinder hoses. Cap hoses and fittings on cylinder.
4. Support the inner leg while removing the upper pin.
5. Swing cylinder inward to rest against inner leg. Carefully lower inner leg out of housing.
6. Remove lower pin snap rings and pin. Using a hoist, pull the cylinder out of the inner leg.

REASSEMBLY & INSTALLATION OF AUXILIARY OUTRIGGERS

1. Extend cylinder 1"-2" and insert into inner leg. Cylinder must be oriented so that ports are to outside when inner leg is installed.

2. Align rod end with holes in inner leg and install pin and snap rings. Apply a thin coat of anti-seize lubricant to pin before installation.
3. If slider pad is still inside outer housing (located under doubler strap at lower end of housing), pry it loose and remove.
4. Inspect slider pad for wear and/or damage. If worn to less than 3/8" thickness over 25% of surface, replace with new pad.
5. Use a heavy gun grease (chassis lube) - applied to back (flat) side of slider pad - to hold pad in place during reassembly.
6. Install inner leg into outer housing and slide up all the way. Make sure the inner leg is oriented correctly.
7. Align cylinder end between housing ears with cylinder ports facing out. Apply never-seize to pin prior to installation.
8. Reconnect cylinder hoses to proper ports.
9. Cycle the leg fully up and down several times to purge air from system and check for proper operation.

Extension Cylinder

HYDRAULIC ASSIST EXTENSION SYSTEM

The extension system on the Load King Stinger extends and retracts by means of a hydraulic cylinder and a series of cables. The picture below describes the cylinder mounting. The cylinder mounts into the boom by a series of mounting trunnions shown in the illustrations below.

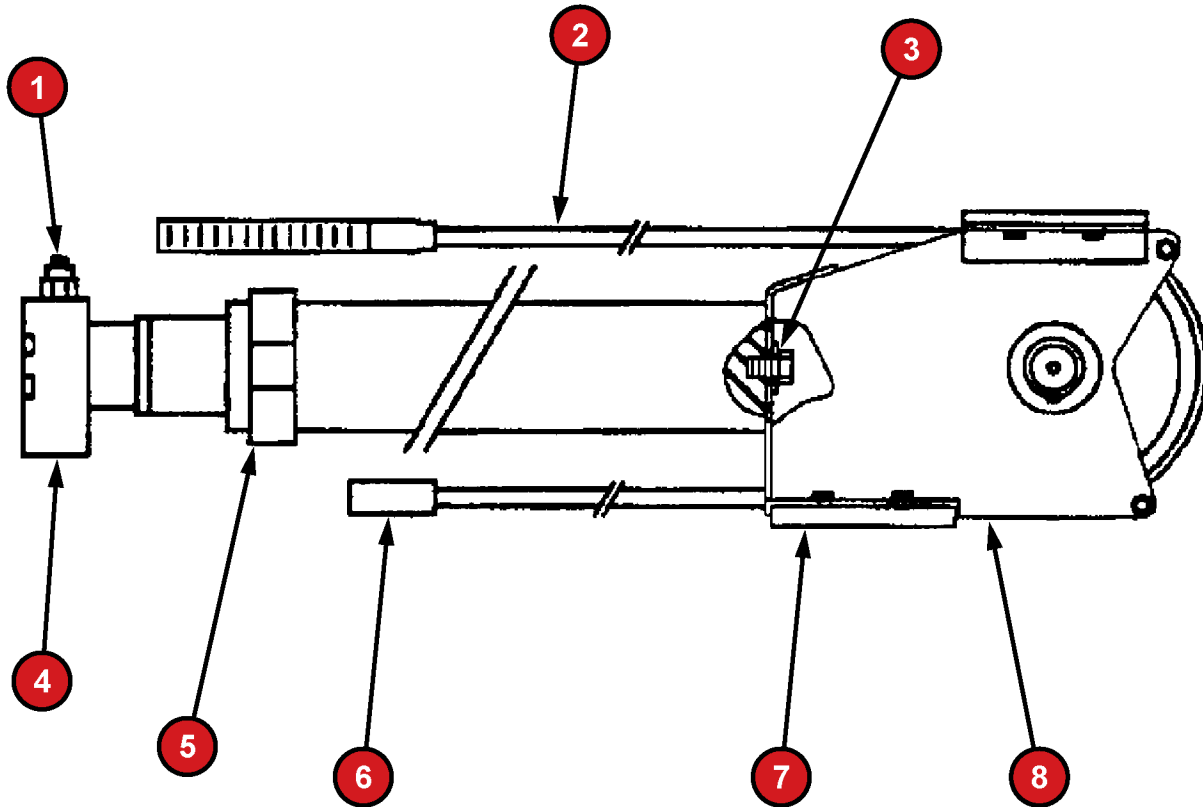

Extension Cylinder Assembly

1	Cartridge	5	2nd Stage Trunion
2	Extend Cable	6	Attachment Lug
3	Retainer Bolt	7	Sheave Bracket
4	Cartridge Block	8	Cable Sheaves

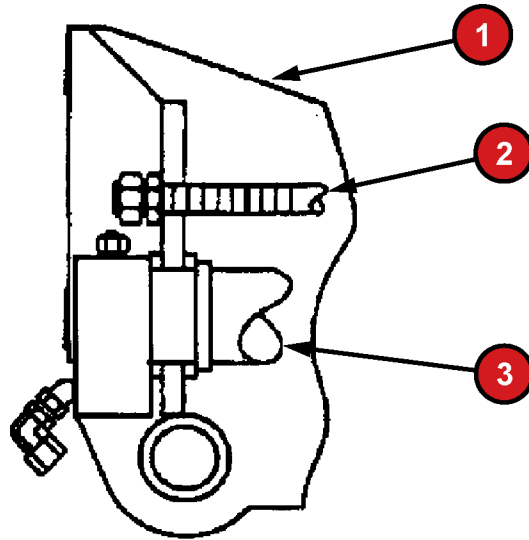

Base Mount

1	Base End of Boom	3	Extension Cylinder
2	Extension Cable Adjustment		

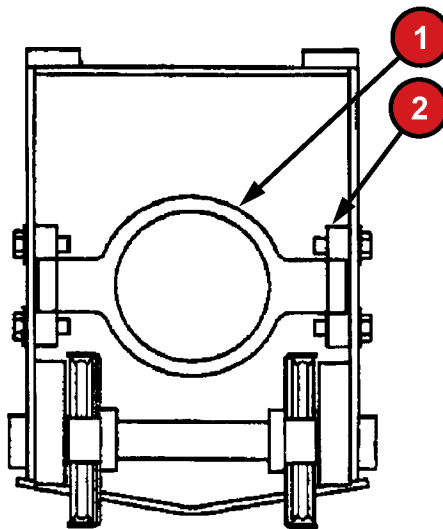

Second Stage Mount

1	Extension Cylinder Mount	2	Boom Mount
---	--------------------------	---	------------

The extension cylinder is equipped with a counterbalance cartridge to hold the rated load suspended. The system is designed so that when the extension handle is pushed to extend, the oil is allowed to free-flow through the counterbalance and into a hollow porting tube in the center of the cylinder rod and into the cylinder's base. The rod side oil is bypassed back to the tank through the retract hose as the boom extends.

When the handle is pulled to retract, the oil is routed directly into the rod side of the cylinder. As pressure is applied, the oil gets into the pilot portion of the counterbalance and pilots it open, allowing the base oil to be exhausted back to tank. See the following illustration:

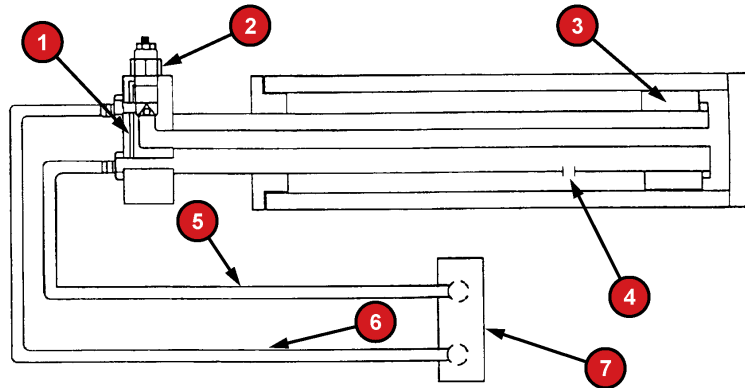

1	Pilot Port	5	Retract Line
2	Counterbalance	6	Extend Line
3	Piston	7	Extend Valve Section
4	Retract Port		

CHECKING LOAD HOLDING

To test the cylinder for holding, the following procedures should be used:

1. Raise boom to maximum angle and extend the boom approximately 3'. Attach a live load, as used in the topping test, to the load line and lift rated load. Raise the load 4"-5" off the ground. Shut off the engine and move the control lever to release hydraulic pressure trapped in the hose. The load should not fall more than 1/2" in 10 minutes. If it does fall more than 1/2", the following troubleshooting procedures should be followed:
2. A leaking cylinder will generally fall into 2 categories.
 - a. External leaks (usually found around the base of the cylinder).
 - i. All weld joints
 - ii. Cartridge O-Rings
 - iii. Cross-drilled passages
 - b. Internal leaks (bypassing within the cylinder or holding cartridge). There are two things that must be checked in order to isolate the source of the leakage:
 - i. Holding Cartridge
 - ii. Piston bypassing from base side to rod side.



DO NOT REMOVE COUNTERBALANCE VALVE UNLESS BOOM IS FULLY RETRACTED AND SUPPORTED TO PREVENT SUDDEN MOVEMENT.



WHEN LOOSENING FITTINGS, HIGH PRESSURE OIL COULD BE PRESENT IF COUNTERBALANCE VALVE IS STUCK OPEN OR IF INTERNAL LEAKAGE IS SEVERE. BOOM SHOULD ONLY BE SLIGHTLY EXTENDED SO THAT SUDDEN MOVEMENT DOES NOT CAUSE INJURY OR PROPERTY DAMAGE

3. Extend boom 3-4" at maximum angle. Remove both the extend and retract hoses at the control valve.
 - a. Oil coming from the boom extend hose indicates bypass from the counterbalance. Clean or replace the counterbalance.
 - b. If oil comes out of the boom retract hose while still engaged in this test, the cylinder is bypassing internally and will require internal repairs.

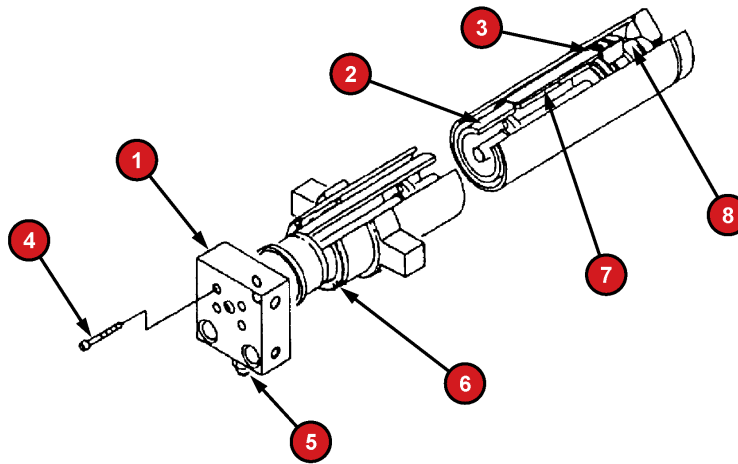

1	Cartridge Block	5	Cartridge
2	Cylinder Rod	6	Thread Ring
3	Piston	7	Sleeve
4	Valve Body Bolt	8	Nut Torque (1500 Ft. lbs.)

CYLINDER OVERHAUL INSTRUCTIONS

For removal of the extension cylinder assembly see Boom Disassembly Procedure.

Contact Load King Service Parts Department to receive overhaul information for the cylinder on the unit. Have the cylinder part number, located on the barrel, available at time of call and the information will be sent to you.

Boom Maintenance, Adjustment and Repair

Wear Pad Adjustment and Replacement

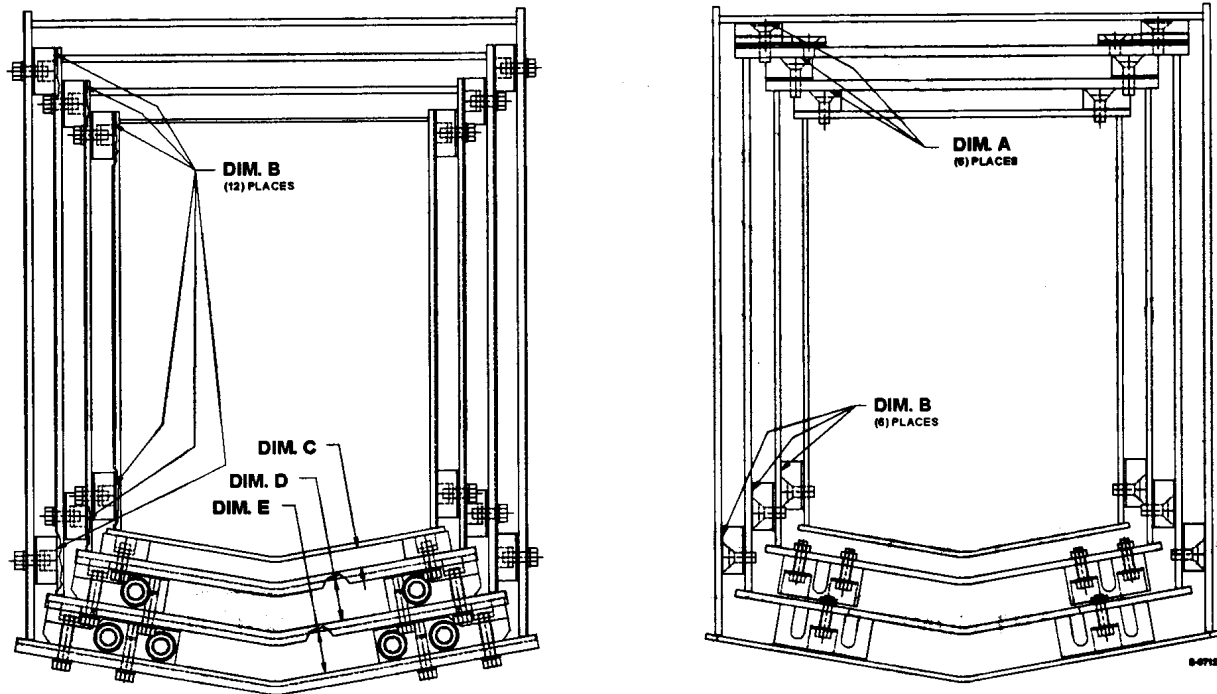

Front View (left) and Rear View (right)

The following notes will apply anytime replacement or removal of any wear pads are involved. Use shims under the pads to attain proper clearances between boom sections. See dimension notes on above illustration for clarification.

Dim A	Rear top wear pads and adjacent boom sections: 1/16" maximum clearance.
Dim. B	Front and rear side wear pads and adjacent boom sections: 1/32" maximum clearance.
Dim. C	Front bottom 3rd and 4th stage boom sections: 3/4"
Dim. D	Front bottom 2nd and 3rd stage boom sections: 1 5/8"
Dim. E	Front bottom base boom and 2nd stage boom sections: 1 5/8".

Front View on the dimension notes illustration above.

1. When making adjustments, remove the shims from one side and add same shims to the other side. Dimension B in Section A no longer applies. Clearance for the bottom wear pads that make contact with the keel sections at the boom tip end sections must be checked to insure shimming is consistent from one side to the other side and both lower pads make contact with the keel surface of the boom.

2. Apply a thin film of brush-type anti-seize lubricant on the base, 2nd, and 3rd stage boom sections where pads make contact, on inside surfaces. On outer boom tip surfaces use lithium based grease. The width and length of lubrication needs to be full wear pad contact area. Use a heavy duty temperature resistant lubricant; Military Spec: MIL-A-9070 Bossert P/N 76764 or equivalent.
3. Apply a thin film of lithium grease (Fleet Industries Stock #1454-SW-G) to the outside surfaces of side plates and bottom plates on 2nd, 3rd, and 4th stage booms where wear pads make contact. Width and length of lubrication to be full wear pad contact area. Apply grease before assembly of boom sections.

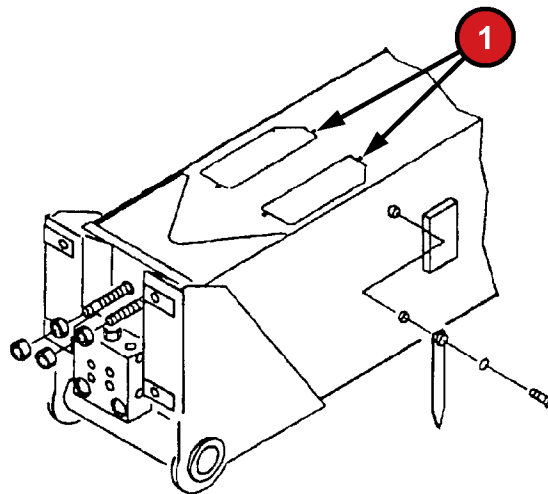

1 Wear Pad Inspection Location: Rear of Base Boom

WEAR PAD REPLACEMENT CHART

PART NUMBER	NEW SIZE	MINIMUM THICKNESS
729-02235	3/4"	5/8"
729-02236	3/4"	5/8"
729-02640	3/4"	5/8"



NOTE: *Wear pad bolts should be either shimmed or shortened as necessary to prevent contact or scraping of the adjacent boom section. Serious damage to boom weldment may occur if these steps are not followed.*



SHUT OFF ENGINE AND DISENGAGE PTO



DO NOT STICK HANDS OR TOOLS IN BOOM SECTIONS UNTIL THE ENGINE IS SHUT OFF AND PTO IS DISENGAGED. SERIOUS INJURY WILL RESULT IF BOOM IS TELESCOPED WHILE HANDS OR TOOLS ARE IN HOLES

REAR TOP WEAR PADS

1. fully retract the boom so the top rear wear pads on the 2nd stage are accessible through the holes in the top of the base section.
2. Measure the thickness of the rear top wear pads on the top of the 2nd stage boom. Replace both wear pads if worn too much to maintain the proper clearance, to avoid unnecessary boom droop.
3. Measure the clearance between the rear top wear pads and the adjacent section.
4. If necessary, loosen the mounting screws and add shims under the wear pads to provide the clearance given in the wear pad clearance chart.

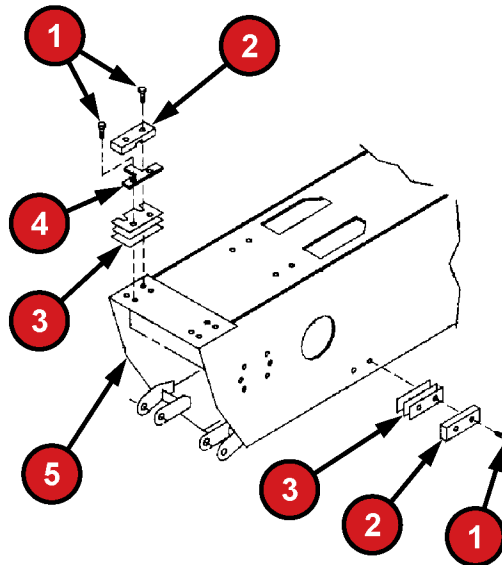

1	Screw	4	Bracket
2	Wear Pad	5	Rear of 2nd Stage Boom
3	Shims		



NOTE: *Shims come in three thicknesses as noted below.*

PART NUMBER	DESCRIPTION	THICKNESS
787-00238 *787-00308	SHIM	0.04
787-00239 *787-00309	SHIM	0.063
787-00240 * 787-00310	SHIM	0.10



NOTE: * These shims used with wear pad # 729-02640 top rear 2nd stage boom.

- Securely tighten the mounting screws after the shims are installed. Use Loctite 242 on all bolts.
- Extend the boom so top rear wear pads on the 3rd stage are accessible through the holes in the base and 2nd stage.
- Repeat Rear Top Wear Pads, Steps 1 through 5 for the 3rd section.



NOTE: Rear side wear pads can only be adjusted or replaced when the boom is disassembled.

FRONT BOTTOM AND SIDE WEAR PADS



SHUT OFF ENGINE AND DISENGAGE PTO



DO NOT STICK HANDS OR TOOLS IN BOOM SECTIONS UNTIL THE ENGINE IS SHUT OFF AND PTO IS DISENGAGED. SERIOUS INJURY WILL RESULT IF BOOM IS TELESCOPED WHILE HANDS OR TOOLS ARE IN HOLES

- Extend the boom approximately 6". Stop the engine and disengage the PTO.
- Measure the thickness of the front side wear pads. Replace all of the wear pads for the respective section if the thickness of any side wear pad has decreased to the minimum dimension given in the previous table. Check for metal to metal contact between the pad fastener and boom.
- Adjust the stages of the boom from side to side until each stage is centered in the adjacent section.
- Measure the clearance between front side wear pads and the adjacent section.
- If necessary, loosen the mounting screws after the shims are installed.
- Securely tighten the mounting screws after the shims are installed.



NOTE: *Mounting screws for the side wear pads must not rub against the adjacent section. If necessary, add washers behind the head of the mounting screws so screws fully engage the nuts in the wear pads but not rub against the section.*

7. Measure the thickness of the front bottom wear pads and replace both wear pads for the respective sections if the thickness of either pad has decreased to the dimension given in the table above.

Readjust the retraction cables after reinstalling mounting pads. See Extension and Retraction Cable Adjustment.

8. Measure the clearance between the sections as in pad clearance chart.
9. If necessary, add shims under the wear pads to provide the clearance given above. Make sure both pads are making contact with the keel of the boom. Shim as high as possible to achieve even contact on both pads without contacting side slider pads.
10. Securely tighten the mounting screws after the shims are installed.

BOOM REMOVAL



ANY LIFTING DEVICE USED SHOULD HAVE CAPACITY OF AT LEAST 10,000 LBS.

1. Fully retract boom and lower onto the boom rest. Disengage the PTO and stop engine.
2. Tag and disconnect the hydraulic lines from the cartridge block on the end of the telescope cylinder. Cap the hose and plug the cylinder ports. Remove winch hoses and cap and plug.
3. Lift against the rod end of the lift cylinder with another crane or suitable hoist and remove the rod pin. Lower the rod end of the cylinder down onto a block.



DO NOT DROP THE LIFT CYLINDER DOWN AGAINST THE TURRET, OR THE BARREL OF THE CYLINDER MAY BE DAMAGED. SUPPORT THE END OF THE CYLINDER SO IT CANNOT MOVE ACCIDENTALLY.

4. Using slings with legs at least 4' long and a capacity of 10,000 lbs. connect to the lifting lugs on top of the base boom and lift slightly. This will be center of gravity for the boom assembly.
5. Remove the boom hinge pin.
6. Lift the boom onto stands or blocking. Stands or blocking must have the capacity of holding approximately 10,000 lbs and be installed close to both ends of boom base to provide a sturdy support preventing any unexpected movement. Secure the boom to these stands.

BOOM DISASSEMBLY PROCEDURE

These instructions assume that the winch assembly has been removed after the boom was removed from the Boom Truck. Any stands or lifting devices used should have the capacity

of holding approximately 10,000 lbs. Stands or blocking must be installed close to both ends of the base boom to provide a sturdy support. The boom should be secured to these stands to prevent any unexpected movement.

It is best if the stands are shaped in such a way that the keel shape of the boom is matched so it will not tilt or fall over during servicing. This will also prevent the boom from being damaged due to self weight. (Large timbers with a “V” cut to match the bottom side of the boom make excellent stands.)



NOTE: *To avoid confusion when reassembling the boom, keep wear pads and shims in matched sets as they are removed. Keep bolts, capscrews, lock washers, and nuts with the parts they retain.*

1. Remove the cartridge block, by cautiously unscrewing the four socket head capscrews. Use caution as there may be some pressure trapped in the cylinder. **MAKE SURE THAT THE O-RINGS DO NOT FALL OUT OF THE CARTRIDGE BLOCK.**
2. Remove the inspection cover on top of the base boom. Remove the lock and jam nuts from the four 3rd stage extend cables protruding from the cylinder mounting at the rear of the base boom. Secure the cables to the cylinder through the inspection hole in the top of the base boom. **BE SURE TO HOLD THE CABLES BY THE WRENCH FLATS PROVIDED ON THE ENDS TO PREVENT TWISTING. FAILURE TO DO THIS WILL RESULT IN DAMAGE TO THE CABLES.**
3. Remove the nuts from the four 3rd stage retract cables at the front of the base boom. Lift the front of the 3rd stage boom to unload the lower pads. Remove the side, top, and lower wear pads as well as cable blocks. **BE SURE TO HOLD THE CABLES BY THE WRENCH FLATS PROVIDED ON THE ENDS TO PREVENT TWISTING. FAILURE TO DO THIS WILL RESULT IN DAMAGE TO THE CABLES.**
4. Carefully slide the 2nd, 3rd, and 4th stages out of the boom. **BE SURE THAT THE RETRACT CABLES ARE PULLED OUT WITH THE BOOM ASSEMBLIES TO AVOID DAMAGING THEM.**

Temporarily reinstall the cartridge block onto the extension cylinder to avoid the possibility of contamination entering the cylinder porting.

5. Remove the retract cable guides from the bottom of the 2nd stage boom, and stretch the 4th stage cables out behind the boom to prevent them from being kinked.
6. Remove the nuts on the 4th stage extension cables from the mounting plate on the upper rear end of the 2nd stage boom. **BE SURE TO HOLD THE CABLES BY THE WRENCH FLATS PROVIDED ON THE ENDS TO PREVENT TWISTING. FAILURE TO DO THIS WILL RESULT IN DAMAGE TO THE CABLES.**

Supporting the weight of the extension cylinder with a hoist, remove the 12 bolts holding the trunnion mount plates to the 2nd stage boom.

Push the trunnion mount plates inboard on the cylinder trunnions.

7. Remove the jam nuts on the 4th stage retraction cables and remove the upper, side and lower front wear pads from the front of the 2nd stage boom. Remove the cable mounting blocks also.

8. Lift the cylinder and extend tube assembly as high as possible, and remove the 3rd stage retract cable sheave pins, sheaves, and cable guides. Remove the 3rd stage retraction cables and inspect for rust, kinks, and any signs of damage.
9. Carefully remove the 3rd and 4th stage assemblies from the 2nd stage boom. The cylinder and extend tube assembly should remain with the 3rd and 4th stage booms.
10. Remove the retract cable retainers from the bottom of the 3rd stage boom. Remove the buck eyes from the retract cable pins and remove the cable guides and sheave assemblies. Lay the retract cables straight out behind the booms to prevent kinking or damage to the cables.
11. Again, raise the base of the extension cylinder as high as possible to gain working room, and remove the three 1/2" bolts anchoring the four 3rd stage extend cables to the extend/retract cable bracket.
12. Remove the four bolts holding the extend/retract bracket to the extend tube assembly. Remove the extend/retract bracket assembly.
13. After devising some means to secure the extend cables to the cylinder barrel, slowly remove the cylinder assembly from the 4th stage and extend tube assembly. Stop about half of the way out and find the approximate center of gravity of the cylinder assembly and reposition the sling. Set cylinder assembly on work stands and disassemble if necessary. Check the extend cables thoroughly for wear and damage.
14. Raise the extend tube assembly as high as possible and remove the 4th stage extend cable anchors in the rear bottom of the 4th stage boom. After securing the 4th stage extend cables to the extend tube, slowly remove the extend tube assembly. Stop about half of the way out and find the approximate center of gravity and reposition the sling. Put the assembly on a work stand and disassemble if necessary

Boom Reassembly

BOOM ASSEMBLY PROCEDURE

These instructions assume that the boom is in a completely disassembled condition. The re-assembly will be carried out in several stages of sub-assembly starting with the 4th stage boom first.

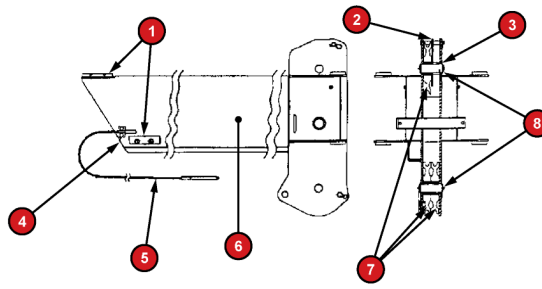

1	Rear, Side and Top Wear Pads	5	Retract Cable
2	Spacer Plate	6	4th Stage Boom
3	Spacer	7	Sheave Assemblies
4	Retract Cable Anchor	8	Sheave Pins

- Starting with the 4th stage boom, assemble sheaves, bearings, pins, and snap rings to the boom tip
- Assemble rear top and rear side wear pads, shimming to proper clearance per the wear pad clearance chart.
- Apply **FS White Lithium Grease 12** to boom sides that contact wear pads and wear pad surfaces. Apply **Northland Moly Tac II Grease Lithium Complex** to top and bottom surfaces of boom that contact wear pads and wear pad surfaces. Using 4" paint roller to apply the grease and a long pole as required to reach internal surfaces.
- Install retract cables and anchor blocks per illustrations on following pages.

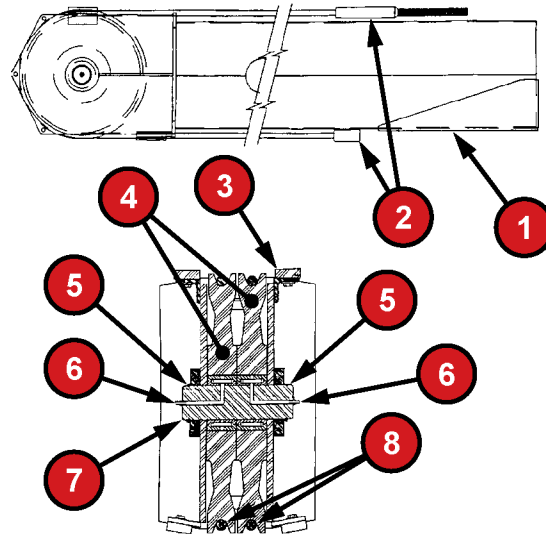

1	Extend Tube Assembly	5	Snap Rings
2	Extend Cables	6	Grease Zerks
3	Wear Pads	7	Sheave Pin
4	Sheaves		

5. Assemble the extend tube assembly as follows:
 - a. Assemble sheaves, bearings, pin, grease zerks, and snap rings to tip of extend tube assembly.
 - b. Grease roller bearings through grease zerks with EP multipurpose grease.
 - c. Install the extend cables into the sheave grooves and install the retaining bolts, nuts, and spacers.
 - d. Install wear pads on tip of sheave weldment.
6. Slide extend tube assembly into the 4th stage until the base end of the extend tube is approximately 2' from the base end of the 4th stage.



NOTE: Use some means of identifying the extend cables so they do not become crossed. Failure to do this could cause severe damage to cylinder and boom assembly.

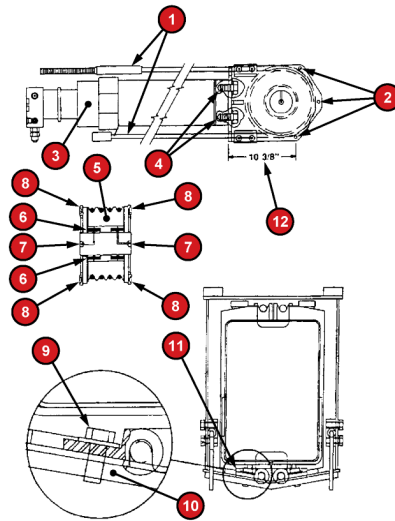

1	Extend Cables	7	Grease Zerk
2	Cable Retainer Bolts	8	Wear Pads - Install with Beveled Corner to the Outside
3	Cylinder	9	Anchor Bolts
4	1" Bolts (torque to 480 ft-lbs. - 4 ea.)	10	Backup Bar
5	4 Grooves Extend Sheave	11	Cable Anchor
6	Sheave Bearings	12	Critical Dimension

7. Lift extend tube assembly as high as possible and install cable anchor and support bar at rear of 4th stage boom. Push cables forward until they contact the boom anchor point. Torque the bolts to 80 ft.lbs.
8. Assemble the extension cylinder assembly as follows:
 - a. Assemble the sheave head unit to cylinder using the 2 1-8NC Gr. 5 bolts with flat and lock washers



NOTE: *The 10 3/8" measurement between the sheave head base and tip is critical and is not symmetrical. This must be at the bottom side as shown.*

- b. Install bearings into the 4 rope extend sheave. Install sheave assembly and sheave pin. Install snap rings and grease zerks.
- c. Install the 4 extend cables around the sheaves with the lugs on the bottom.
- d. Tie ends of cable to cylinder so they can not be accidentally crossed.



NOTE: *Failure to do this could result in serious damage to cylinder and weldments.*

- e. Install pads on the outside of the bracket weldment with the chamfered edges to the outside of the bracket as in the illustration. **THIS IS A CRITICAL STEP - NOT DOING THIS MAY CAUSE DAMAGE TO THE PADS.**

- f. Install bolts, washers, spacers, and lock nuts through sheave tip to retain cables.
 - g. Grease roller bearings through grease zerks installed in each end of the sheave pin. Be sure to use a multipurpose EP type of grease.
9. Assemble rear, side, and top wear pads to the 3rd stage boom.
 10. Apply **FS White Lithium Grease 12** to boom sides that contact wear pads and wear pad surfaces. Apply **Northland Moly Tac II Grease Lithium Complex** to top and bottom surfaces of boom that contact wear pads and wear pad surfaces. Using 4" paint roller to apply the grease and a long pole as required to reach internal surfaces.
 11. Bottom surface of the 4th stage boom keel and inside surface of the 3rd stage boom keel to be free of all foreign material.
 12. Slide the 4th stage boom and extend tube assembly part way into the 3rd stage boom, making sure not to damage the 4th stage retract cables.
 13. Pull the 4th stage retract cables out of base end of the 3rd stage as 4th stage boom and extend tube are pushed into the 3rd stage boom.
 14. Assemble the 4th stage retract cable guides over the cables and attach guides to the bottom of the 3rd stage boom. Make sure the cables are identified so they will not be crossed.



NOTE: *Failure to do this could result in serious damage to cylinder and weldments.*

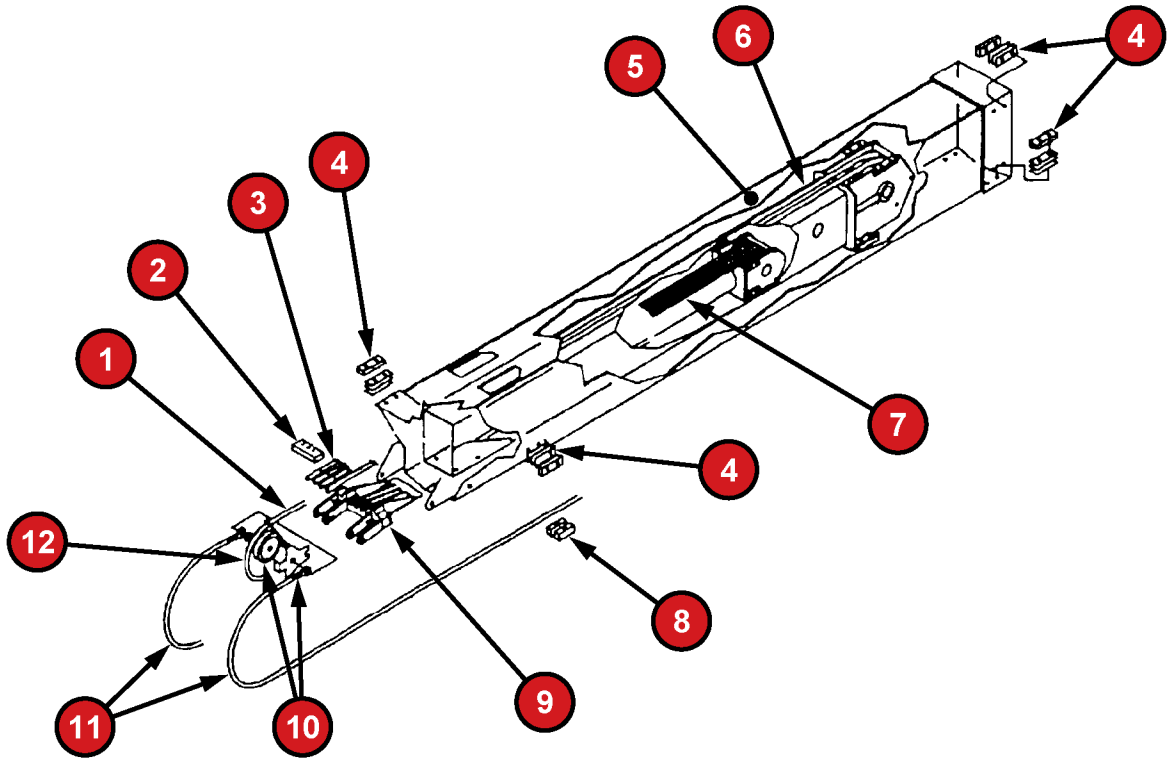

1	4th Stage Retract Cable	7	Extension Cylinder Assembly
2	Cable Clamp	8	Cable Retainer
3	Extend Cables	9	Extend/Retract Bracket
4	Wear Pads	10	Retract Sheave & Guide
5	3rd Stage	11	2nd Stage Retract Cables
6	Assembly	12	4th Stage

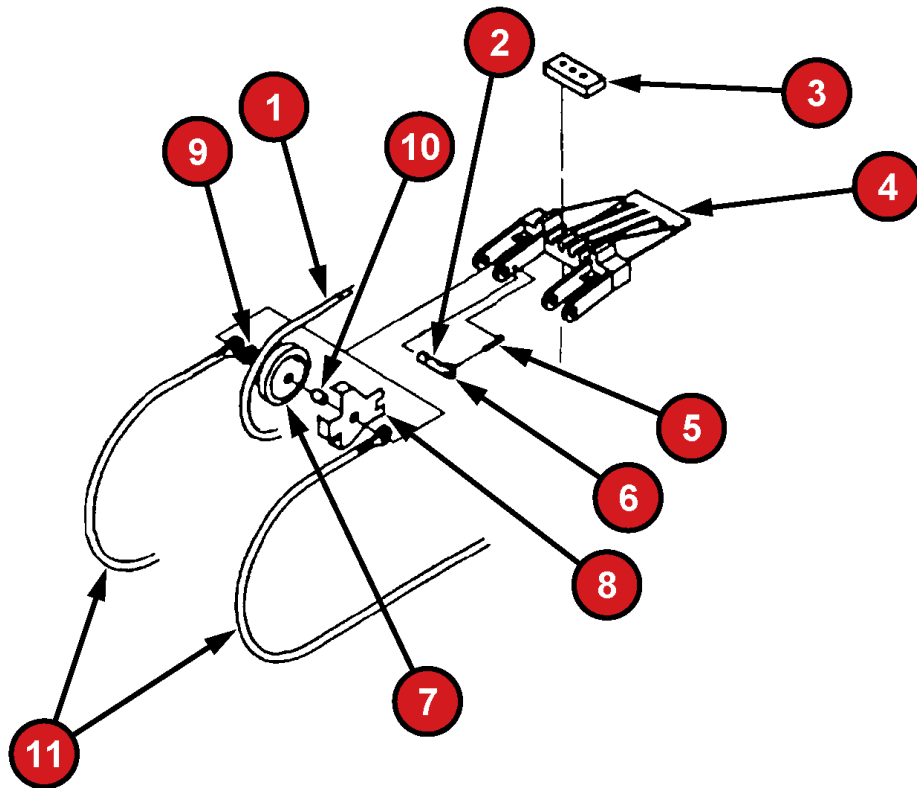

1	4th Stage Retract Cable	7	Sheave
2	Retainer Pin	8	Sheave Guard
3	Cable Clamp Block	9	Bushing
4	Extend/Retract Cable Anchor	10	Bearing
5	Buckeye	11	3rd Stage Retract Cable
6	Sheave Pin		

15. Assemble the front side of the bottom wear pads into the front of the 3rd stage boom, shimming as required to achieve the clearances called out in the boom shimming chart.
16. Slide the 4th stage boom all the way in until it bottoms out against the 3rd stage boom.
17. Slide extension cylinder assembly part way into the extend tube. Assure cables are identified so they can not be crossed.



NOTE: Failure to do this could result in serious damage to cylinder and weldments.

18. Raise the extension cylinder assembly as high as possible and install the extend/retract cable anchor to the extend tube base.
19. Attach the ends of the extend cables to the extend/retract cable anchor.
20. Slide extend cylinder assembly into the extend tube assembly until the extension cylinder trunnion is approximately 12" from the base of the extend tube assembly.

21. Slide the extend tube assembly into the 4th stage boom until the holes in the extend/retract anchor line up with the holes in the 3rd stage boom. Raise the extend tube assembly and extension cylinder assembly to align the holes.
22. Install retract cable sheaves, pins, retainers, and 3rd stage cables. Route the 4th stage retract cables over retract sheaves during this operation. Insure that the cables are not crossed.



NOTE: Failure to do this could result in serious damage to cylinder and weldments.

23. Place trunnion blocks onto the extend cylinder trunnion and position them as close as possible to the cylinder body. Holes must be oriented to match mounting holes 2nd stage boom.
24. Grease retract sheave bearings with EP multipurpose grease.

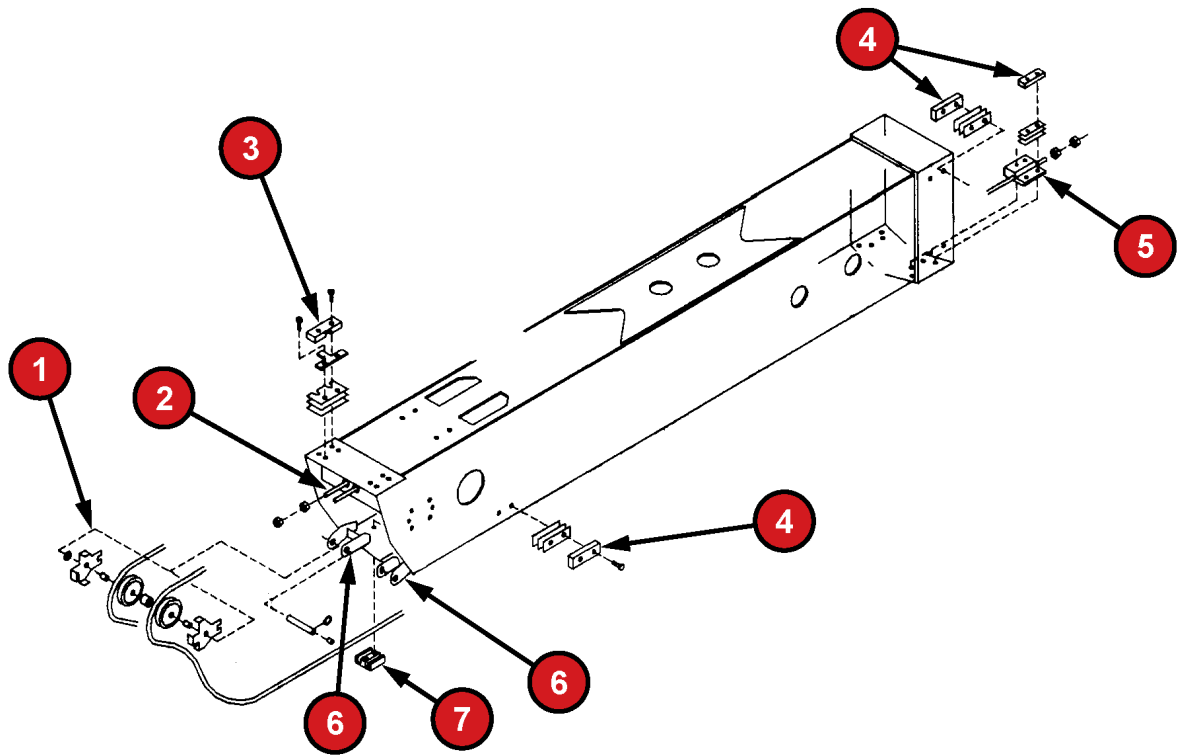

1	Retract Sheave Assembly	5	Retract Cable Block
2	4th Stage Extend Cables	6	Retract Sheave Bracket
3	Wear Pad Assembly	7	Cable Guide Block
4	Wear Pad		

25. Slide entire assembly part way into the 2nd stage boom, making sure not to damage the 4th stage retract cables. Pull the 3rd stage retract cables out through the base end of the 2nd stage boom.
26. Assemble 4th stage retract cables to retract block. Loosely assemble nuts. Make sure retract cables are not crossed.



NOTE: Failure to do this could result in serious damage to cylinder and weldments.

27. Assemble front side and bottom wear pads to 2nd stage boom. See section on shimming for proper shimming procedures. Also install retract cable blocks.
28. Apply **FS White Lithium Grease 12** to boom sides that contact wear pads and wear pad surfaces. Apply **Northland Moly Tac II Grease Lithium Complex** to top and bottom surfaces of boom that contact wear pads and wear pad surfaces. Using 4" paint roller to apply the grease and a long pole as required to reach internal surfaces.
29. Slide the entire 3rd stage subassembly into the 2nd stage boom until the 3rd and 2nd bottom out.
30. Assemble the 3rd stage cable guides over the 3rd stage retract cables, and attach them to the 2nd stage boom. Securely tighten bolts. Use some means of identification to avoid crossing the retract cables.
31. Attach the extend cylinder to the 2nd stage boom at trunnion mounts with the trunnion blocks, bolts, and washers.



NOTE: Be sure to loctite the bolts and torque to 280 ft.lbs.

32. Insert ends of the 4th stage extend cables through the anchor plate at the base end of the 2nd stage boom. Loosely assemble the nuts and make sure the extend cables are not crossed.



NOTE: Failure to do this could result in serious damage to cylinder and weldments.

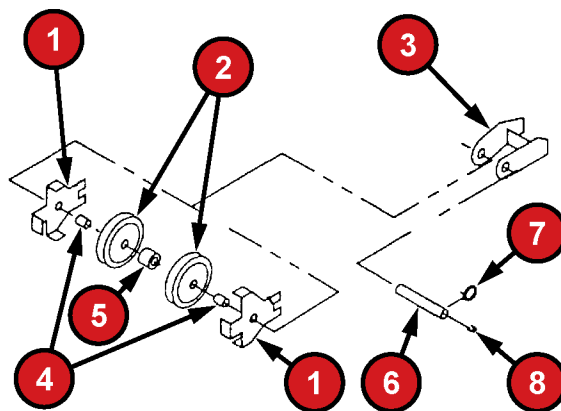

1	Cable Retainer	5	Spacer
2	Retract Cable Sheaves	6	Sheave Pin
3	2nd Stage Retract Bracket	7	Snap Ring
4	Bearings	8	Zerk

33. Install the 3rd stage retract cable sheaves, pins, spacers, and cable retainers on base end of 2nd stage boom. Route the 3rd stage retract cables over the retract sheaves during this operation.

34. Remove the cartridge block from the extension cylinder and manually pull the cylinder rod out approximately 24". Take precautions to prevent dirt from getting into the cylinder ports.
35. Assemble the top and side rear wear pads to the 2nd stage boom. Adjust clearance in accordance with the wear pad clearance section of this manual. Verify the inside surfaces of the base boom are free of all foreign material.
36. Check that the bottom surface of the 2nd stage boom is smooth and free of all foreign material.

Apply **FS White Lithium Grease 12** to boom sides that contact wear pads and wear pad surfaces. Apply **Northland Moly Tac II Grease Lithium Complex** to top and bottom surfaces of boom that contact wear pads and wear pad surfaces. Using 4" paint roller to apply the grease and a long pole as required to reach internal surfaces.

37. Slide the entire assembly partially inside the base boom, being very careful not to damage the 3rd stage retract cables and cable guides.
38. Assemble the 3rd stage retract cables to the retract cable blocks with the nuts loosely threaded on. Make sure the retract cables are not crossed.



NOTE: *Failure to do this could result in serious damage to cylinder and weldments.*

39. Install retract cable anchor blocks. Assemble front side and bottom wear pads to base boom in accordance with the wear pad clearance section of this manual.
40. Slide the entire assembly further into the base boom until the end of the cylinder rod is close to the mounting plate at the rear of the base boom.
41. Using the rear access holes in the base boom, line the cylinder rod end up with the hole in the rear mounting plate. Slide the assembly in until the cylinder rod is fully engaged into the mounting hole.
42. Assemble manifold block to cylinder rod end making sure o-rings are in place and counterbalance valve is in the downward position. Torque the capscrews to 70-85 ft.lbs.
43. Insert the ends of the 3rd stage extend cables through the cylinder mounting plate using the access holes provided. Loosely assemble the nuts to the cables after making sure the cables are not crossed.



NOTE: *Failure to do this could result in serious damage to cylinder and weldments.*

44. Assure that bushings have been installed in the base boom. If they have not, a stepped mandrel tool should be used to drive the bushing in, and the holes and housing bore should be clean and free of burrs to avoid damage to the bushing surface.

BOOM INSTALLATION



SHUT OFF ENGINE AND DISENGAGE PTO. DO NOT STICK HANDS OR TOOLS IN BOOM SECTIONS UNTIL THE ENGINE IS SHUT OFF AND PTO IS DISENGAGED. FAILURE TO DO THIS MAY RESULT IN SEVERE PERSONAL INJURY, INCLUDING LOSS OF HANDS OR FINGERS!

1. Lift the boom into position at the turret and install the boom hinge pin.
2. Lower the boom onto the boom rest.
3. Reinstall the lift cylinder and hook up hydraulic lines.
4. Connect the hydraulic lines to the cartridge block on the cylinder.
5. Plug or cap the end of the hoses or tubes for the winch. This step must be performed so oil does not leak out of the lines when Step 7 is performed.
6. Adjust extension cable system. (See Boom Cable Adjustment Procedure.)
7. Once the extension cable system is properly adjusted, assemble the winch to the base section. Tighten the mounting bolts to 280 ft.lbs.



NOTE: *Step 6 is easier to perform when the winch is not installed.*

8. Connect the hydraulic lines to the ports of the winch motor.
9. Install the load line over the sheaves of the boom tip. Be sure to pass the load line under wire cable guides on the end of the boom sections.
10. If equipped, assemble the jib to the side of the boom.
11. Connect the ATB cable to the limit switch and test the ATB system for proper operation.
12. Operate the winch and the telescope cylinder in both directions until all air is bled from the system. Check the level of oil in the hydraulic tank.

Boom Cable Adjustment Procedure



SHUT OFF ENGINE AND DISENGAGE PTO. DO NOT STICK HANDS OR TOOLS IN BOOM SECTIONS UNTIL THE ENGINE IS SHUT OFF AND PTO IS DISENGAGED. FAILURE TO DO THIS MAY RESULT IN SEVERE PERSONAL INJURY, INCLUDING LOSS OF HANDS OR FINGERS!

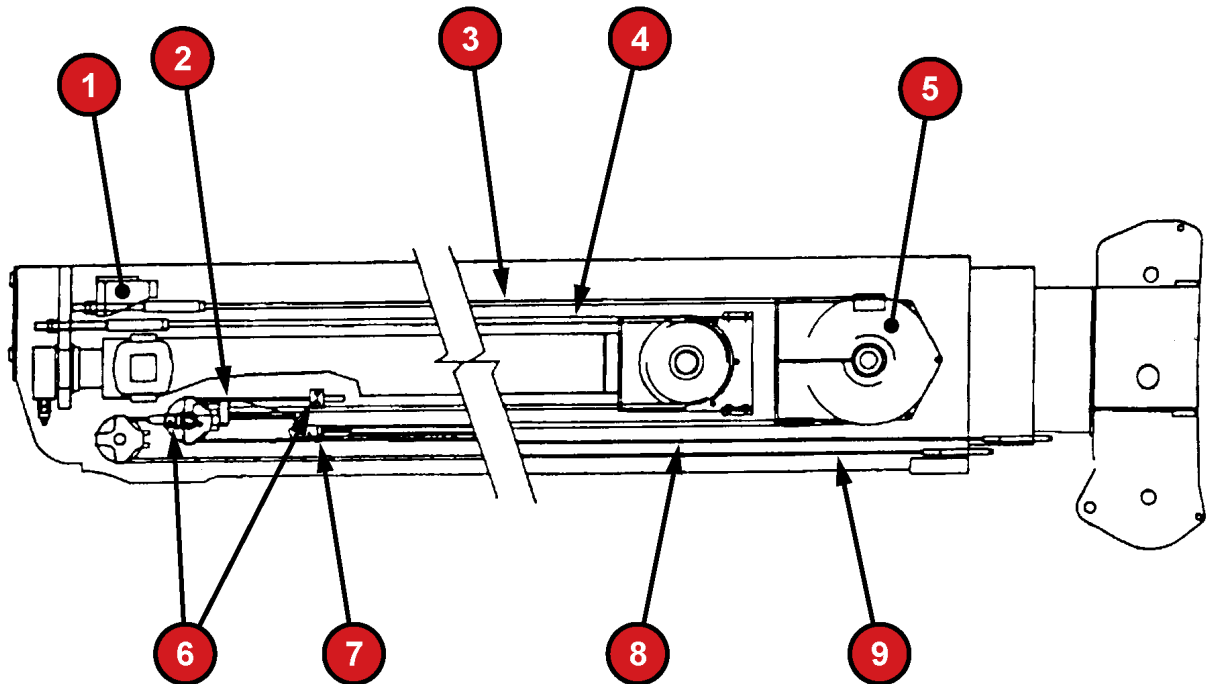

1	2nd Stage Boom	6	3rd & 4th Stage Retract Anchors
2	3rd Stage Extend Anchor	7	4th Extend Anchor
3	4th Extend Cables	8	4th Retract Cable
4	3rd Stage Extend Cables	9	3rd Retract Cable
5	4th Extend Tube		

1. Loosen the adjusting nuts on the 3rd stage extend cables so that the cables are slack. Be sure to hold the cable from rotating as the nuts are turned.
2. Extend the boom approximately 3' to 4' and remove power. Working through the access hole in the top of the base boom section, remove the lock nuts and loosen the jam nuts on the 4th stage extend cables until the cables are slack.
3. Fully retract the boom and put a match mark "A" on the side of the 2nd stage boom, flush with the end of the base boom section. Put a match mark "B" on the side of the 3rd stage boom flush with the end of the 2nd stage boom.
4. Extend the boom approximately 3' to 4' and remove power. Working through the access hole in the side of the base boom, check the tension of the 4th stage extend

- cables by hand. Tighten the adjusting nut on the loosest cable until the two cables are equally tensioned.
5. Tighten the adjusting nuts on the 4th stage retract cables to 25 ft.lbs.
 6. Fully extend the boom and check tension of the 4th stage extend cables. Tighten the adjusting nut on the loosest cable until the cables are equally tensioned.
 7. Fully retract the boom while watching the 4th and 3rd stages. Note whether the 4th stage stops before the match mark B aligns itself with the end of the second stage boom.
 8. Extend the boom approximately 6" and repeat step 7 as slowly as possible. Remove power as soon as the 4th stage stops or as soon as match mark B is fully aligned, whichever occurs first.
 9. Determine the remaining stroke to fully retract the booms as follows:
 - A. If the 4th stage boom stopped first, measure the remaining stroke between match mark on the 3rd stage boom and the end of the end of the second stage boom.
 - B. If match mark B aligned itself first, measure the remaining stroke between the 4th and 3rd stages (at the bottom, where the 3rd stage tip contacts the 4th stage tip weldment).
 10. If the remaining stroke is greater than 1/8" proceed as follows:
 - A. Extend the boom approximately 3' to 4' and remove power
 - B. If the 4th stage stopped first:
 - i. Loosen the adjusting nut on each extend cable 2 turns for each 1/8" of remaining stroke.
 - ii. Tighten the adjusting nut on each retract cable 1 1/2 turns for each 1/8" of remaining stroke.
 11. Repeat steps 7-10 until the remaining stroke is 1/ 8" or less.
 12. Recheck the torque of the adjusting nut on the 4th stage retract cables and assure that the torque setting is still at 25 ft.lbs.
 13. Recheck the torque of the adjusting nut on the 4th stage retract cables and assure that the torque setting is still at 25 ft.lbs.
 14. Extend the boom approximately 3' to 4' and remove power. Working through the access hole in the base section, check the tension of the 3rd stage extend cables by hand. Tighten the adjusting nut on the loosest cables until all four cables are tensioned equally.
 15. Torque the adjusting nut on the 3rd stage retract cables to 25 ft.lbs. (four cables)
 16. Fully retract the boom while watching the 2nd and 3rd stages. Note which stage stops first.
 17. Extend the boom approximately 6" and repeat step 16. Note which boom section stops first.
 18. Determine the remaining stroke to fully retract the boom as follows:
 - A. If the 3rd stage stopped first:

- Measure the remaining stroke between match mark A on the 2nd stage boom section and the base boom.
- B. If the 2nd stage stopped first:
- Measure the remaining stroke between match mark B on the 3rd stage and the end of the 2nd stage.
19. If the remaining stroke is greater than 1/8" proceed as follows:
- A. Extend the boom approximately 3' to 4' and remove power.
- B. If the 3rd stage stopped first:
- Loosen the adjusting nut on each retract cable 1 1/2 turns for each 1/8" of remaining stroke.
 - Tighten the adjusting nut on each extend cable 2 turns for each 1/8" of remaining stroke.
- C. If the 2nd stage stopped first:
- Loosen the adjusting nut on each extend cable 2 turns for each 1/8" of remaining stroke.
 - Tighten the adjusting nut on each extend cable 1 1/2 turns for each 1/8" of remaining stroke.
20. Repeat steps 16-19 until the remaining stroke is 1/8" or less.
21. Recheck the torque on the retract cables and assure that they are still at 35 ft.lbs.
22. Cycle the boom two or three more times and check that all boom sections are properly synchronized per the above instructions. If not synchronized, check which sections require adjustment and perform the proper adjustment procedure to correct.
23. Repeat step 22 until the boom is properly synchronized.
24. Recheck the torque on all the retract cables and insure that all adjusting nuts are installed and jammed.
25. Install the inspection cover on the top of the base boom section.



SHUT OFF ENGINE AND DISENGAGE PTO. DO NOT STICK HANDS OR TOOLS IN BOOM SECTIONS UNTIL THE ENGINE IS SHUT OFF AND PTO IS DISENGAGED. FAILURE TO DO THIS MAY RESULT IN SEVERE PERSONAL INJURY, INCLUDING LOSS OF HANDS OR FINGERS!

Rotation Gear and Gearbox

Removal/Installation of Rotation Gear and Gearbox



NOTE: *The following instructions assume the boom has been removed from the turret.*

1. Thoroughly steam clean unit in rotation gear area.
2. Remove the rotation gearbox from its mounting and lay it on the control console. It is not necessary to disconnect the hydraulic lines when performing this step.
3. Disconnect grease tubes from fittings on swing bearing, 2-places.
4. Use inner bolt circle access slots in turret to remove inner bolts in groups. Rotate turret as needed to reposition slots. Support turret / gear assembly while removing last group of bolts.
5. Lift turret/bearing assembly off mainframe and set aside where bearing can be removed from turret.
6. Both the turret and mainframe bearing mounting surfaces must be carefully inspected for flatness and smoothness. Remove all burrs and ridges that might prevent the bearing race from sitting flat. Maximum surface flatness tolerance is .006 TIR. in any 90° segment. See table below.

INITIAL MOUNTING SURFACE ERROR (INCHES)

Raceway Diameter (Inches)	Single-Row Ball Bearings
Up to 40	0.006
40 to 60	0.0075
60 to 80	0.009
80 to 100	0.010
100 to 120	0.012
120 to 140	0.014
160 to 240	0.016

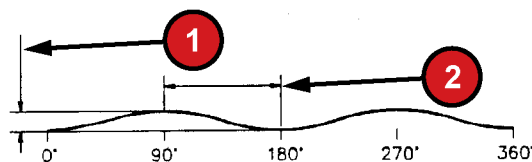

1 Mounting Surface Error (TIR)	2 Minimum Span
--------------------------------	----------------

7. Assemble new bearing to turret using new bolts, hardened flat washers, and nuts. Tighten the nuts to 100 ft.lbs first, then tighten the nuts to 610 ft.lbs. (dry) or 450 ft.lbs (lubed). See bolt torque sequence chart below.

Inspection of Rotation Bearing Clearance

1. It is not feasible to make an analysis of the condition of the rotation gear while it is on the unit. There are too many variables involved for this to be accurate.
2. A bearing may cause a problem in the operation of the Boom Truck or the confidence of the operator long before it would be deemed structurally unsafe.

To properly check the radial clearance of the rotation gear, it must first be removed from the Boom Truck and placed on a heavy flat table. Remove all dirt and grease from the outside of the gear and secure it to the table with clamps, assuring that the inner raceway rotates freely after clamping it to the table.

As shown in the figure below, attach a large “C” clamp in position #1, and tighten just enough to take all the slack out of the raceway. Install a dial indicator as close to position #1 as possible, and set it to “0”.

As shown in the figure below, attach a large “C” clamp in position #1, and tighten just enough to take all the slack out of the raceway. Install a dial indicator as close to position #1 as possible, and set it to “0”.

Remove the “C” clamp and attach at clamp location #2 and again tighten just enough to take up the slack in the two raceways. Look at the dial indicator, noting the amount of change in the reading. This measurement is the radial clearance of the bearing. The following bearing clearances should be observed.

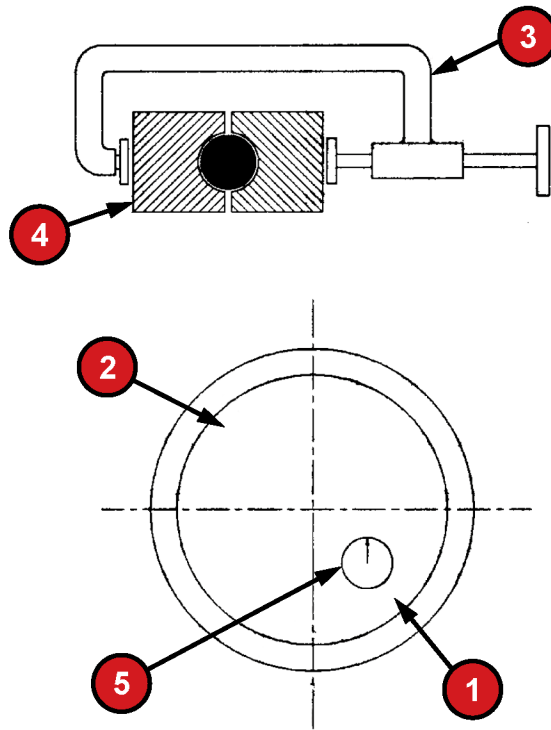

Radial Clearance Check Procedure

1	Clamp Position #1	4	Rotation Gear
2	Clamp Position #2	5	Dial Indicator
3	"C"Clamp		

1. Any new bearing being installed on a Load King Boom Truck should not have more than .004 - .007 radial clearance.
2. Any bearing taken off a unit which has .030 - .050 radial clearance should be screened carefully for roughness while rotating. If excessively rough, the bearing should be disassembled and thoroughly inspected for damage in the raceways, and for rust or pitting.

Backlash Adjustment

The rotation mechanism should be checked periodically for any signs of looseness or excess lash between the gears.

The procedure for setting backlash is as follows:

1. Locate the high spot on the rotation gear. This spot is marked with yellow paint at the time of manufacture of the bearing. You will be able to see this spot by wiping away some of the gear grease. The high spot can also be located with a dial indicator by rotating the bearing assembly without the swing gearbox installed.
2. Be sure the high spot is aligned to the pinion; turn the eccentric cam ring until the gears are in mesh and there is no clearance at all.
3. Install a dial indicator as shown in the following illustration and set to 0.

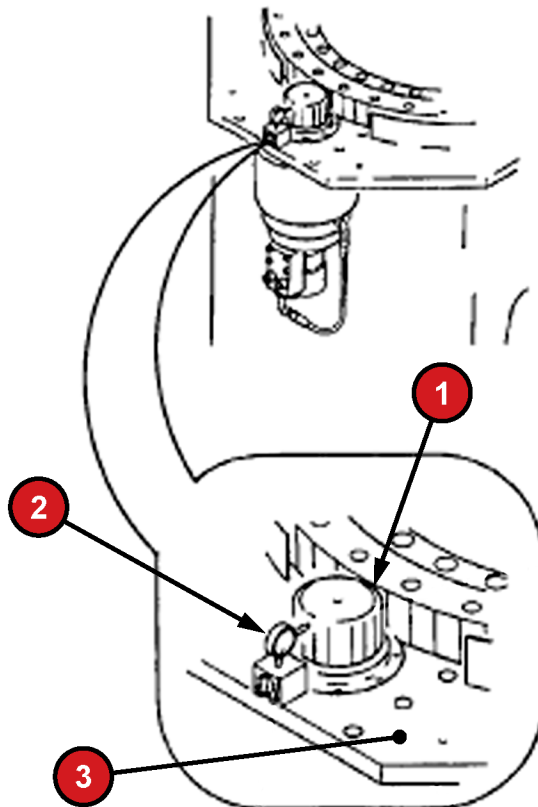

1	Pinion	3	Mainframe Top Plate
2	Dial Indicator		

4. Loosen the mounting bolts holding the gearbox just enough so that the gearbox may be moved when the eccentric cam ring is turned.
5. Rotate the cam ring slowly until the reading is .020 - .025.
6. Remove the gearbox bolts one at a time and apply new LOC-TITE to the threads. Retorque the bolts to 280 - 300 ft.lbs.



Coat rotation gearbox pilot and mainframe pilot bore with anti-seize compound to prevent rust and binding of the eccentric ring.

Internal RCI Cable Repair

EXTERNAL CABLE BREAK

In the case that the RCI cable breaks outside of the boom, DO NOT EXTEND BOOM.

Attach replacement cable to broken cable. Pull new cable through boom assembly by pulling broken cable from boom head.

INTERNAL CABLE BREAK

In the case that the RCI cable breaks inside of the boom, follow the procedure below.

Completely retract boom. Boom down over side of machine to access boom head.

You must feed a 30 foot long 1/4" rod through the RCI internal cable guide assembly, so that the cable can be pulled through from the front.

Start by feeding the rod through the sight hole in the front of the boom head.

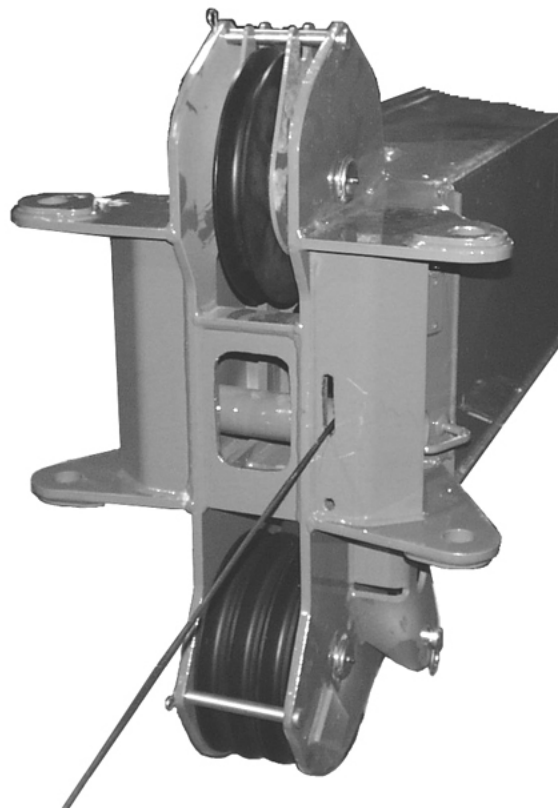

The rod must then be routed through the two cable guides mounted to the side of the extend cylinder sheave bracket.

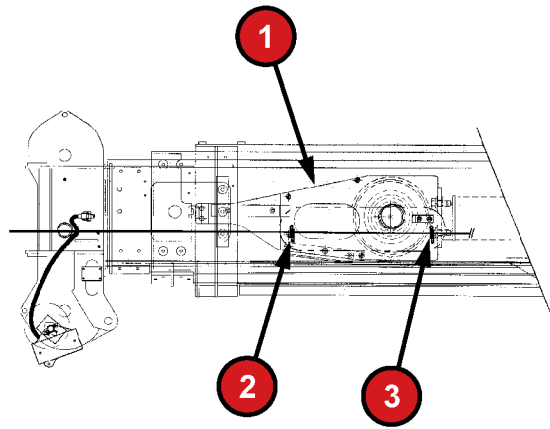

1	EXTEND CYLINDER SHEAVE BRACKET	3	CABLE GUIDE 2
2	CABLE GUIDE 1		

After the rod is through Cable Guide 1 it may be necessary to lift the rod up or down to align with Cable Guide 2

After routing the rod through guide 2, feed it all the way to the rear of the tip section. (Approximately 25')

Extend boom until access holes align in top of boom sections. (Approximately 1' of boom per section)

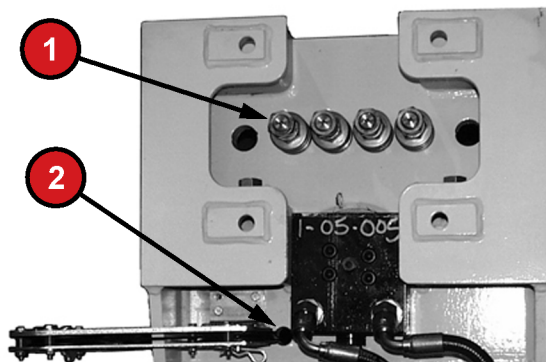

1	Left Extend Cable	2	Cable Hole
---	-------------------	---	------------

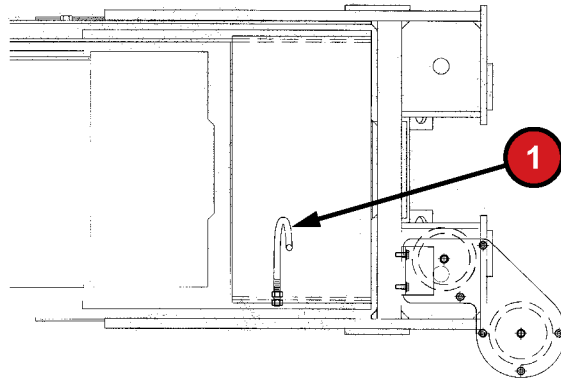

TOP VIEW

1	Cable Eyelet
---	--------------

Loosen left-most extend cable so that you can access the rod on the bottom plate of the boom with your hand. Make sure that the rod is fed straight through. Do not allow the rod to be wrapped by any extend cables. Feed the rod through cable eyelet mounted to the inner left side of the boom and then through cable hole at the base of the boom.

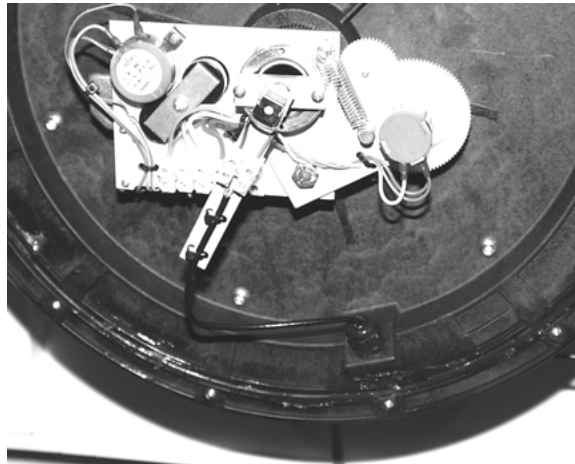

Remove cover from RCI cable reel and discard broken cable. Attach the new cable to the reel. Wind cable onto reel.

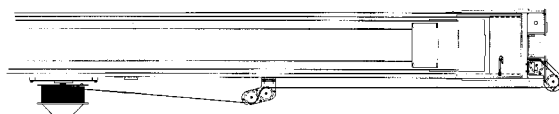

Route cable through both sheave assemblies.

Tape the eyelet end of the new RCI cable to the end of the rod. Make sure that the eyelet is on top of the rod and aligned vertically so that the rod and eyelet can pass through the cable guides.

Pull the cable back through until you have pulled the cable out through the front of the boom head.

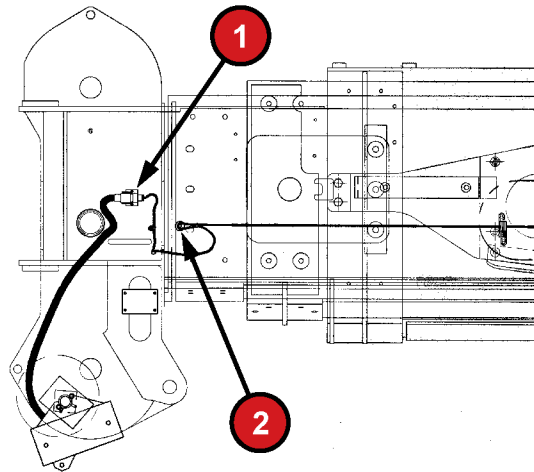

1	ATB PLUG	2	THIMBLE RETAINING SCREW
---	----------	---	-------------------------

Place thimble onto retaining screw. Access inner end of screw by reaching through the hole in the front of the boom head. Attach fender washer and hex nut. If using a replacement washer, make sure that it is a fender washer with a large enough diameter to hold the cable thimble. Route bare end of wire through hole in tip section. Disassemble receptacle and remove damaged cable. Wire new wire cable ends into receptacle and reassemble. Plug ATB switch plug into receptacle.

Page Intentionally Blank

Conversion Tables

DECIMAL AND METRIC EQUIVALENTS OF FRACTIONS OF AN INCH

Fractions of an Inch	Decimals of an inch	Millimeters
1/64	0.0156	0.397
1/32	0.0313	0.794
3/64	0.0469	1.191
1/16	0.0625	1.588
5/64	0.0781	1.985
3/32	0.0938	2.381
7/64	0.1094	2.778
1/8	0.1250	3.175
9/64	0.0406	3.572
5/32	0.1563	3.969
11/64	0.1719	4.366
3/16	0.1875	4.762
13/64	0.2031	5.159
7/32	0.2188	5.556
15/64	0.2344	5.953
1/4	0.2500	6.350
17/64	0.2656	6.747
9/32	0.2813	7.144
19/64	0.2969	7.541
5/16	0.3135	7.937
21/64	0.3281	8.334
11/32	0.3438	8.731
23/64	0.3594	9.128
3/8	0.3750	9.525
25/64	0.3906	9.922
13/32	0.4063	10.319
27/64	0.4219	10.716
7/16	0.4375	11.12
29/64	0.4531	11.509
15/32	0.4688	11.906
31/64	0.4844	12.303

**&!- &A
Appendix**

Fractions of an Inch	Decimals of an inch	Millimeters
1/2	0.5000	12.700
33/64	0.5156	13.097
17/32	0.5313	13.494
35/64	0.5469	13.891
9/16	0.5625	14.287
37/64	0.5781	14.684
19/32	0.5938	15.081
39/64	0.6094	15.478
5/8	0.6250	15.875
41/64	0.6406	16.272
21/32	0.6563	16.688
43/64	0.6719	17.085
11/16	0.6875	17.462
45/64	0.7031	17.859
23/32	0.7188	18.256
47/64	0.7344	18.653
3/4	0.7500	19.050
49/64	0.7656	19.447
25/32	0.7813	19.843
51/64	0.7969	20.240
13/16	0.8125	20.637
53/64	0.8281	21.034
27/32	0.8438	21.430
55/64	0.8594	21.827
7/8	0.8750	22.224
57/64	0.8906	22.621
29/32	0.9063	23.018
59/64	0.9219	23.415
15/16	0.9375	23.812
61/64	0.9531	24.209
31/32	0.9688	24.606
63/64	0.9844	25.003
1	1.0000	25.400

WEIGHTS AND MEASURES

LIQUID MEASURE (U.S.)

4 gills	=	1 pint
2 pints	=	1 quart
4 quarts	=	1 gallon
7.48 gallons	=	1 cu. ft.
240 gallons of water	=	1 Ton
340 gallons of gasoline	=	1 Ton

LIQUID MEASURE (METRIC)

1 litre	=	0.0353 cu. ft.
1 litre	=	0.2642 gallon
1 litre	=	61.023 cu. in.
1 litre	=	2.202 lbs. of water(62°F.)
1 cu. foot	=	28.32 litres
1 gallon	=	3.785 litres
1 cu. inch	=	0.0164 litre

MEASURES OF WEIGHTS (U.S.)

16 ounces	=	1 pound
2000 pounds	=	1 short ton
2240 pounds	=	1 long ton
100 cu. feet	=	1 register ton
40 cu. feet	=	1 U.S. shipping ton

MEASURES OF WEIGHTS (METRIC)

1 gram	=	0.0353 ounce
1 kilogram	=	2.205 lbs.
1 ounce	=	28.35 grams
1 pound	=	0.454 kilogram
1 ton	=	0.907 metric ton

CIRCULAR MEASURE

60 seconds	=	1 minute
60 minutes	=	1 degree
90 degrees	=	1 quadrant
360 degrees	=	1 circumference

ELECTRICAL UNITS

1 kilowatt	=	1.34 H.P.
1 horsepower	=	746 watts

SURVEYOR'S MEASURE

7.92 inches	=	1 link
100 links	=	66 feet or 4 rods or 1 chain
80 chains	=	1 mile

Average Weight of Materials

MATERIAL	KG/CU. METER	KG/CU. FOOT	1 CU. YARD
Ashes - Piled Dry	560.70	35	945
Brick Bats	881.10	55	1485
Cement - Portland	1505.88	94	2538
Charcoal	400.50	25	695
Cinders	881.10	55	1485
Clinker - Portland Cement	1361.70	85	2295
Clay - Dry, in Lumps	1009.26	63	1701
Clay - Compact, Natural Bed	1746.18	109	2943
Coal - Anthracite	897.12	56	1512
Coal - Bituminous R of M Piled	881.10	55	1485
Coal - Bituminous Slack, Piled	801.00	50	1350
Coke - Blast Furnace Size	432.54	27	729
Coke - Foundry Size	448.56	28	756
Concrete - Ready to Pour	2370.96	148	3996
Dolomite - Crushed Fine	1521.90	95	2565
Dolomite - Broken Lump	1521.90	95	2565
Earth - Loamy, Dry Loose	1201.50	75	2025
Earth - Dry, Packed	1521.90	95	2565
Earth - Wet (Mud)	1762.20	110	2970
Flue Dust - Blast Furnace	1842.30	115	3105
Flue Dust - Blast Furnace, Wet	2403.00	150	4050
Gypsum - Crushed to 3"	1521.90	95	2565
Gypsum - Calcined	961.20	60	1620
Gravel - Dry, Loose	1762.20	110	2970
Gravel - Dry, Packed	1810.26	113	3051
Gravel - Wet, Packed	1922.40	120	3240
Iron Ore - 60% Iron	4806.00	300	8100
Iron Ore - 50% Iron	4005.00	250	6750
Iron Ore - 40% Iron	3204.00	200	5400
Iron Punchings - Scrap	4325.40	270	7290
Iron Turnings - Scrap	2803.50	175	4725
Limestone - Run of Crushed	1521.90	95	2565
Limestone - Fines Out	1602.00	100	2700

**&! - &A
Appendix**

MATERIAL	KG/CU. METER	KG/CU. FOOT	1 CU. YARD
Limestone - 1 1/2 or 2 Graded	1361.70	85	2295
Limestone - Above 2 Graded	1281.60	80	2160
Phosphate, Acid (Fertilizer)	1361.70	85	2295
Phosphate, Rock	1281.60	80	2160
Pyrites	2167.70	135	3645
Salt	929.16	58	1566
Sand - Dry, Loose	1521.90	95	2565
Sand - Wet, Packed	1922.40	120	3240
Scale - Rolling Mill, Wet	2114.64	132	3564
Shale - Broken	1361.70	85	2295
Slag - Blast Furnace, Broken	2210.76	138	3726
Slag - Open Hearth, Crushed	1682.10	105	2835
Slag - Granulated, Dry	606.76	38	1026
Slag - Granulated, Wet	929.16	58	1566
Snow	528.66	33	891
Sulphur - Broken	528.66	60	1620
Timber - Green Cedar	592.74	37	999
Douglas Fir	606.76	38	1026
Hemlock	656.82	41	1107
Southern Pine	881.10	55	1485
Spruce	576.72	36	972
Redwood	801.00	50	1350
Zinc Ore - Broken	2403.00	150	4050

Personnel Platform Installation & Operation Manual

Greer Insight Operation's Manual

Your crane is set up with a Greer Insight Rated Capacity Indicator (RCI) system. Completely read the attached manual in the Appendix section and view the Setup & Operations Video DVD (Part No. 12261-644) supplied in your crane manual pack before attempting to operate the crane.



Crane Limited Product Warranty

Load King LLC ("Load King") warrants to the original Buyer its new Products will be free, under normal use and service, of any defects in material or workmanship for a period of (i) two years (24 months), or (ii) 2,000 hours of operation. In addition, the warranty period is five years (60 months) for structural crane weldments (boom section, jib, outrigger beam, subbase, frame, mounting anchors, mast, turntable). Each of those aforementioned periods shall commence at the date of initial installation or commission; provided, however, those periods, in the case of a distributor of Load King, shall commence no later than six (6) months after the date of shipment by Load King. Parts fitted during a warranty repair will take on the remaining warranty time period only. The foregoing warranties shall be honored provided that Load King receives written notice of the defect within thirty (30) days of its discovery, but in no event later than fifteen (15) days after the expiration of the applicable warranty period, and it has been established that (i) the Product has been maintained and operated within the limits of rated and normal usage and in strict compliance with Load King's operating and maintenance manuals, (ii) the defect did not result in any manner from the intentional or negligent action, inaction or abuse by Buyer or any third party, and (iii) in the case of structural warranty, all annual inspections have been completed by an authorized Load King service center. If it cannot be established that conditions (i), (ii) and (iii) above have been met, then this Warranty shall not cover the alleged defect.

If requested by Load King, the defective Product must be returned to Load King, or other location designated by Load King, for inspection. Load King reserves the right to review the Product's maintenance procedures to determine if any alleged defect is covered under this Warranty. Delivery inspection forms are required for warranty validation and processing.

Load King's obligation and liability under this Warranty is expressly limited to, at Load King's sole option, repairing or replacing, with new or remanufactured parts or components, any part, which appears to Load King upon inspection to have been defective in material or workmanship. Replacement parts will be provided to Buyer subject to Load King's current warranty claim handling processes. All Products replaced under this Warranty become the property of Load King.

Accessories, assemblies and components included in the Product, which are not manufactured by Load King, are subject to the warranty of their respective manufacturers. Load King does not provide any warranty and Load King specifically disclaims any liability relating to the boom-truck carriers; however, Purchaser may be entitled to the respective boom-truck carrier OEM's pass-through warranty (subject to any registration requirements).

This Warranty shall be null and void if parts (including wear parts) other than genuine Load King Parts are used in or attached to the Product or if serial numbers have been altered, defaced, or removed with respect to Load King's Products or if the Product has been altered without Load King's written agreement.

LOAD KING MAKES NO OTHER WARRANTIES, EXPRESS OR IMPLIED, AND MAKES NO WARRANTIES OF MERCHANTABILITY OR FITNESS FOR ANY PARTICULAR PURPOSE.

No employee or representative is authorized to modify this Warranty unless such modification is made in writing and signed by an authorized officer of Load King.

This warranty is continuous for the above stated periods, and "stopping and restarting" such periods ("stop and go") is not accepted by Load King.

Load King's obligation under this Warranty shall not include the items listed below as "Items not covered by this Warranty."

NO TRANSFERABILITY OF THIS WARRANTY: This Warranty is limited to Buyer or, if sold through a distributor of Load King, to the first End User of the Product, and is not assignable or otherwise transferable without the written agreement of Load King.

ITEMS NOT COVERED BY THIS WARRANTY

The following items are not covered under this Warranty (the following list is not exhaustive):

- Normal maintenance, adjustments, maintenance parts or wear parts, including without limitation wear pads, seals, gaskets, hoses, friction plates, glass, clutch and brake linings, filters, wire rope, exterior coatings, proper tightening of bolts, nuts and fittings, adding or replacing of fluids, filters, breathers, belts, nozzles, adjustments of any kind, service supplies such as hand cleaners, towels and lubricants, inspections, diagnostic time, travel time, or labor.
- Products sold by any individual, corporation, partnership or any other third party that is not authorized by Load King to distribute the Product.
- Damage or defect caused by, or other costs related to, work performed by personnel not authorized by Load King to service or repair the Product.
- Damage or defect caused by operation of the Product by personnel or users not authorized or instructed or trained to operate the Product.
- Costs including, without limitation, travel, freight and labor, resulting from shipment or transfer of the Product into or use in a region not covered by Load King's service network.
- Costs including, without limitation, travel, freight and labor, related to the disassembling and assembling of any equipment with respect to a defective Part integrated in such equipment not covered by Load King's warranty.
- Damage or defect resulting from improper storage, weathering, lack of use, demonstration use, or use for transportation of corrosive chemicals.
- Damage or defect resulting from operation of the Product after a failure, damage or defect noticeably occurred, or damage or defect caused by worn parts or fluids.
- Damage or defect caused by operation or storage of the Product under extreme weather or geographical conditions, including without limitation, fires, freezing, floods, other natural disasters and abnormal conditions of temperature, moisture, dirt or corrosive matter, without the written agreement of Load King.
- Damage or defect caused by non-compliance with Load King's campaign bulletins, product safety and service releases.
- Damage or defect caused by carrier handling. Any such claim for damage should be filed immediately with the respective carrier.
- Cost including, without limitation, travel, freight and labor, resulting from the lack of Buyer or the user of the Product to comply with their obligations under this Warranty.
- Damage or defect resulting from or costs related to acts of God.

THIS WARRANTY IS EXPRESSLY IN LIEU OF AND EXCLUDES ALL OTHER WARRANTIES, REPRESENTATIONS AND CONDITIONS, EXPRESS OR IMPLIED AND ALL OTHER STATUTORY, CONTRACTUAL, TORTIOUS AND COMMON LAW OBLIGATIONS OR LIABILITY ON LOAD KING'S PART ARE HEREBY EXPRESSLY EXCLUDED TO THE MAXIMUM PERMITTED BY LAW. THERE ARE NO WARRANTIES THAT EXTEND BEYOND THE LIMITED WARRANTY CONTAINED HEREIN. Load King neither assumes nor authorizes any other person to assume for Load King any other liability in connection with the sale of Load King's Product. In the event that any provision of this Warranty is held unenforceable for any reason, the remaining provisions shall remain in full force and effect.

IN THE EVENT OF ANY BREACH OF THE WARRANTY BY LOAD KING, LOAD KING'S LIABILITY SHALL BE LIMITED EXCLUSIVELY TO THE REMEDIES (AT LOAD KING'S SOLE OPTION) OF REPAIR OR REPLACEMENT OF ANY DEFECTIVE PRODUCT COVERED BY THE WARRANTY. NOTWITHSTANDING ANYTHING CONTAINED IN THIS WARRANTY TO THE CONTRARY, LOAD KING SHALL NOT BE LIABLE FOR AND SPECIFICALLY DISCLAIMS ALL INDIRECT, CONSEQUENTIAL, INCIDENTAL OR OTHER DAMAGES OR LOSSES WHETHER OR NOT ADVISED OF THE POSSIBILITY THEREOF. Nothing in this Section shall operate to exclude Load King's liability for death or personal injury when directly related to Load King's negligent act or omission.



www.loadkingmfg.com

Load King
7701 Independence Ave, Kansas City, MO
64125
Parts: (816) 241- 8387
Service: (833) 281-7911
Email: info@loadkingmfg.com



Load King | Operator Manual