

# LOAD KING



## OPERATOR'S MANUAL

**LOAD KING**

**50-155 M & U**



**WARNING:** Operating, servicing and maintaining this equipment can expose you to chemical including engine exhaust, carbon monoxide, phthalates, and lead, which are known to the State of California to cause cancer and birth defects or other reproductive harm. These chemicals can be emitted from or contained in other various parts and systems, fluids and some component wear by-products. To minimize exposure, avoid breathing exhaust, do not idle the engine except as necessary, service your equipment and vehicle in a well-ventilated area and wear gloves or wash your hands frequently when servicing your equipment or vehicle and after operation. For more information go to [www.P65Warnings.ca.gov/passenger-vehicle](http://www.P65Warnings.ca.gov/passenger-vehicle).

Breathing diesel engine exhaust exposes you to chemicals known to the State of California to cause cancer and birth defects or other reproductive harm.

- Always start and operate the engine in a well-ventilated area.
- If in an enclosed area, vent the exhaust to the outside.
- Do not modify or tamper with the exhaust system.
- Do not idle the engine except as necessary.

For more information go to [www.P65warnings.ca.gov/diesel](http://www.P65warnings.ca.gov/diesel).

**PAGE INTENTIONALLY LEFT BLANK**

# Table of Contents

<b>Introduction</b> .....	<b>11</b>
About Custom Truck One Source .....	11
Construction and Industrial Equipment Product Safety .....	12
Nomenclature .....	13
Intended Use .....	14
Bulletin Distribution and Compliance .....	14
Contacting the Manufacturer .....	14
Product Information Number .....	15
Load King Warranty Data Record .....	15
Crane Limited Product Warranty .....	16
<b>Specifications</b> .....	<b>19</b>
Features .....	19
Crane Measurements .....	20
Wire Rope Specifications .....	23
<b>Safety</b> .....	<b>25</b>
Owners, Users, and Operators .....	25
Safety Definitions Used in This Manual .....	26
Safety Guidelines .....	27
Personal Protection Equipment .....	27
Workplace Safety .....	28
Effects of Wind Conditions .....	34
Temporary Interruption of Crane Operations .....	36
Potential Hazards Presented by an Unattended Crane .....	37
Lock Out and Tag Out .....	39
Access/Egress Safety .....	41
Personal Safety .....	44
<b>Description of Machine and Controls</b> .....	<b>45</b>
Controls in the Cab .....	45
Operator's Seat Controls .....	48
Upper Controls and Instruments .....	56
Control Screens .....	59
Power Take-Off (PTO) .....	67

Carrier Controls and Instruments . . . . .	68
Outrigger Controls Screen . . . . .	69
Side-Stow Jib . . . . .	70
Load Moment Indicator and Anti-Two-Block . . . . .	71
<b>Operating Instructions . . . . .</b>	<b>73</b>
Job Site . . . . .	73
Outrigger Position . . . . .	74
Work Site Position . . . . .	75
Cold Weather Operation . . . . .	76
General Operational Issues . . . . .	77
Safety Devices . . . . .	79
Training and Operator Qualifications . . . . .	80
Operator Aids . . . . .	81
Maximum Load and Boom Angle Charts . . . . .	82
Boom Angle Placards . . . . .	84
Operating the Unit . . . . .	85
Jump Starting an Engine - Booster Cable Instructions . . . . .	88
Unusual Operating Conditions . . . . .	89
Arm and Hand Signals . . . . .	93
Initiating Operation . . . . .	95
Lifting the Load . . . . .	96
Making a Typical Lift . . . . .	97
Moving the Unit . . . . .	102
<b>Jib Deployment and Stowage . . . . .</b>	<b>105</b>
Deploying the Jib . . . . .	105
Extending the Stinger . . . . .	114
Retracting the Stinger . . . . .	118
Routing the Winch Rope for Fourth (4th) Pin Alignment . . . . .	120
Removing the Winch Rope from the Fourth (4th) Pin Alignment . . . . .	120
Changing the Offset of the Jib . . . . .	121
Stowage . . . . .	124
Jib Stow Assist Remote . . . . .	130
Spooling Wire Rope on Drums . . . . .	131

Hoist-Line Reeving .....	135
Cable Reeving .....	139
Counterweight Installation .....	140
<b>Transportation .....</b>	<b>145</b>
Driving the Boom Truck .....	145
Driving the Boom Truck with the Jib Deployed.....	147
Pre-Move Check List.....	148
<b>Inspection .....</b>	<b>151</b>
Pre-Start Inspection .....	151
Crane Boom.....	152
Structural Members and Welds.....	153
Wire Rope Inspection .....	154
Mobile Crane Load Test Inspection .....	156
<b>Maintenance and Service .....</b>	<b>159</b>
Introduction.....	159
General Service Information .....	159
During Maintenance - Safety Practices.....	160
During Maintenance - General Work Practices.....	161
Operator Observation.....	161
Storing Components.....	162
Cleanliness .....	162
Maintenance Task Lists .....	163
Machine Maintenance Checklist .....	166
Hydraulics System .....	168
Hydraulic System Maintenance .....	170
Hydraulic Hoses .....	174
Fluids and Filter Maintenance .....	175
Cold Weather, Extreme .....	176
Cold Weather Recommendations .....	177
Aluminum Decking and Fender Maintenance Procedure.....	181
Operator's Cab HVAC .....	182
HVAC Fault Diagnostics .....	183
Refrigeration Circuit Maintenance Notes .....	185

Master Lubrication Chart .....	186
Hydraulic Oil Requirements .....	188
Boom Lubrication .....	191
Swing System Maintenance .....	196
Swing Reducers .....	197
Swing Bearing Bolting Procedure .....	198
Slider Pad Maintenance and Lubrication .....	200
Turntable and Swing Pinion .....	201
Wire Rope and Reeving .....	202
Winch Lubrication .....	204
Wire Rope Lubrication .....	205
Anti-Two-Block System .....	208
Machine Storage .....	209
Restoration of Machine to Service .....	211
Outrigger Position Sensors .....	212
Torque Wrench Extensions .....	214
Hydraulic System .....	215
Pumps .....	221
Rotation System .....	222
Electrical System .....	223
Fuse Block-Operator's Cab .....	223
Relay and Fuse Block-Chassis .....	225
Electrical System Collector Ring .....	226
Maintenance-Free Battery Testing .....	228
<b>Troubleshooting .....</b>	<b>231</b>
Introduction .....	231
General Procedure .....	232
Hydraulics - General .....	233
Swing Circuit .....	234
Boom Hoist Circuit .....	235
Telescope Circuit .....	236
Winch Circuit .....	237
Outrigger Controls .....	238
Outrigger Circuit .....	238

Swing Pumps Circuit .....	239
Swing Circuit Control Valves .....	241
Swing Circuit Control Valves .....	242
Fluid Motor .....	243
Cylinders .....	244
Cylinder Leakage .....	245
Excessive Heating of Oil in System .....	247
Electrical Controls .....	248
Two-Block System.....	248
<b>Checklist and Inspection Forms.....</b>	<b>249</b>
Suggested Hydraulic Crane Inspection Checklist .....	249
Daily Check (8 Hours) .....	251
Weekly Check (40 Hours) .....	251
Monthly Check (80 hours).....	252
Semiannual Checks (1000 Hours) .....	253
Annual Check (1500 - 2000 Hours).....	253
Wire Rope Inspection Record.....	254
<b>Appendix .....</b>	<b>257</b>
General Bolt Torque Values .....	257
Coefficient of Friction for Torque Values .....	257
Hydraulic Fitting Torque Values .....	258
Hydraulic Flange Fitting Torque Values .....	259
Subframe Torque Values .....	260
Swing Drive Torque Values .....	262
Winch Mounting Torque Values .....	263
Outrigger Jack Torque values .....	264
Greer Insight Operator's Manual .....	265

**PAGE INTENTIONALLY LEFT BLANK**

## 50-155 M & U

Introduction

About Custom Truck One Source



## Introduction

**Load King** has been producing first-class heavy equipment since 1956. Cutting-edge innovation and engineering excellence make us the market leader. **Load King** is a key part of the Custom Truck One Source family of brands, offering standard and custom trailers, vocational equipment, and a full line of Boom Trucks and Truck Cranes. For more information, please visit **Load King's** website: [www.loadkingmfg.com](http://www.loadkingmfg.com).

## About Custom Truck One Source

Custom Truck One Source is the first true single-source provider of specialized truck and heavy equipment solutions. With sales, rentals, aftermarket parts and services, equipment customization, remanufacturing, financing solutions, and asset disposal, our team of experts, vast equipment breadth and integrated network of locations across North America offer superior service and unmatched efficiency for our customers.

## 50-155 M & U

Introduction

Construction and Industrial Equipment Product Safety

### Construction and Industrial Equipment Product Safety

It is the responsibility of the owner of the equipment to be knowledgeable about federal, state and local regulations that effect the total usage of the equipment, and responsibility to working personnel and the public. Since regulations are subject to change, and differ from one locality to another, this manual makes no attempt to provide such information.

**Load King** provides appropriate operation and maintenance manuals for various construction and industrial equipment products that it manufactures and sells. Appropriate national consensus standards, industry standards, and safety-related manuals are included with the shipment of each **Load King** product as applicable. It is company policy to provide this information for the owner or Operator of the equipment. It is expected that the owner or Operator will utilize these manuals and standards to provide the appropriate information and training to those people who are to operate, maintain, and supervise the use of equipment.

Construction and industrial equipment is designed and manufactured to perform heavy-duty work. Under normal usage, the equipment will wear. For this reason it is essential that the owner/Operator establish and perform a periodic inspection of the equipment. The objective of inspection programs is to prevent accidents, reduce downtime and keep the equipment working efficiently. These inspection programs should be designed to discover worn, cracked, broken or deteriorated parts and loose or missing fasteners before they result in a problem.

Proper training and inspection programs are essential to avoid injuries to persons, damage to property and excessive maintenance costs.

Read and understand the manuals provided with this equipment. Assistance is available from the distributors of your **Load King** product and from the **Load King** manufacturing facility.



When operating a hydraulic crane, the Operator should realize that hydraulic and structural competence, not tipping load, is often the determinant of lifting capacity. The Operator must be guided solely by the appropriate manufacturer's load rating chart when considering load weights. The manufacturers rated loads must never be exceeded.

Follow the recommended operating and maintenance procedures in order to keep your machine operating at maximum efficiency. Use the suggested Inspection Checklist, refer to Checklist and Inspection form section "[Suggested Hydraulic Crane Inspection Checklist](#)". In addition, a maintenance log should be kept in conjunction with all maintenance performed on the machine.

For any additional information regarding the care and operation of the machine, contact the **Load King** service representative. Include the machine model and serial number in all communication to aid service personnel in providing the correct information.

The information, specifications, and illustrations in this publication are based on the information in effect at the time of approval for printing. **Load King** reserves the right to make changes at any time without obligation.

## Nomenclature

This manual contains instructions and information on the operation, maintenance, lubrication and adjustments of the Boom Truck. The Operator should not attempt to operate the machine before he has gained a thorough understanding of the material presented in the following pages. To aid in understanding the contents of this manual, the following terms will always have the meanings given whenever they are used.

1. SUPERSTRUCTURE Supports swing mechanism, Operator's cab, boom, winch, and hoist cylinders.
2. BOOM The telescopic boom with hydraulic winch, lift cylinder, hook block assembly, and jib arrangement.
3. DECK The deck of the Boom Truck.
4. SUBFRAME The frame of the crane that is mounted to the truck chassis and supports the deck and superstructure.
5. OUTRIGGERS The beams, cylinders, floats, boxes, and hydraulic control system.
6. TRUCK The vehicle on which all boom and Operator structures are mounted.

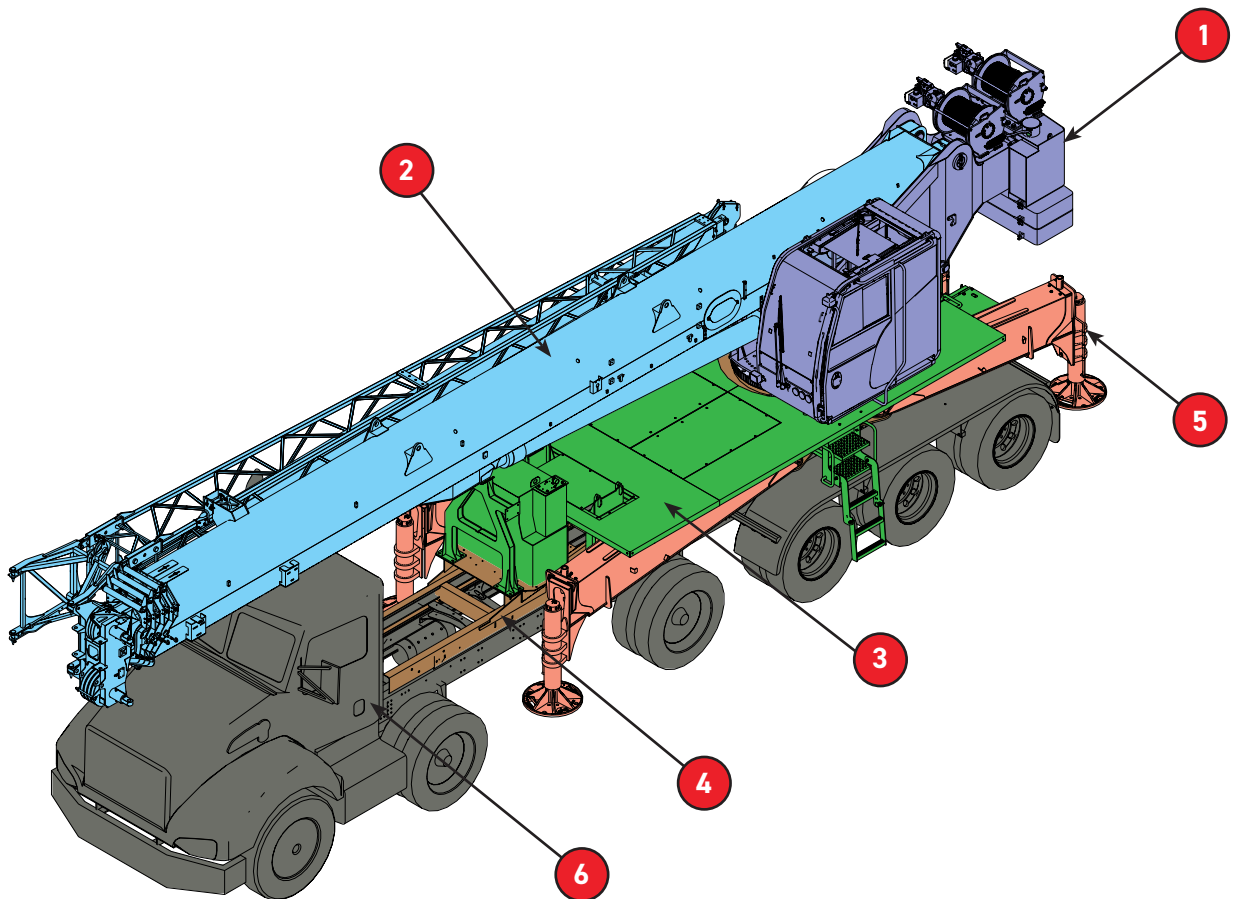
**50-155**

## 50-155 M & U

Introduction

Intended Use

### Intended Use

This mobile crane is designed to lift, lower, move, and position freely suspended loads within its rated capacity while on firm, level ground. The crane is designed exclusively for assembly type, non-duty cycle operations. Use of this product in any other way is prohibited and contrary to its intended use.

Other crane applications outside of the intended use statement above must be approved in writing by **Load King**.

### Bulletin Distribution and Compliance

Safety of product users is of paramount importance to **Load King**. Various service bulletins are used by **Load King** to communicate important safety and product information to dealers and machine owners. The information contained in these service bulletins is tied to specific machines using the machine's model number and PIN/serial number. Distribution of service bulletins is based on the most current owner on record, along with the associated dealer; so it is important to register the machine and keep contact information up to date. To ensure the safety of personnel and the reliable continued operation of your machine, it is essential to implement the actions indicated in all relevant service bulletins.

### Contacting the Manufacturer

When it is necessary to contact the manufacturer, please be prepared to supply the model name, product identification number (PIN), and serial number of the machine, along with your name and contact information. At minimum, the manufacturer should be contacted for:

- Accident reporting
- Questions regarding product applications and safety
- Standards and regulations compliance information
- Questions regarding product modifications
- Current owner updates, such as changes in machine ownership or changes in contact information (see [Product Information Number](#) in this chapter for more information)

#### Manufacturer contact information:

Custom Truck One Source

7701 Independence Ave.

Kansas City, MO 64125

Parts: (816) 241- 8387

Service: (833) 281-7911

info@customtruck.com

<https://store.loadkingmfg.com>

# 50-155 M & U

Introduction  
Product Information Number



## Product Information Number

Taking a few minutes to update owner information will ensure that you receive important safety, maintenance and operating information that applies to your machine.

Please register your machine by visiting us on the web at [www.loadkingmfg.com](http://www.loadkingmfg.com) or calling us toll free at 833-571-1466.

## Load King Warranty Data Record

Warranty Form Submission		Date	
Date of Delivery			
Model Number			
S/N			
Dealer			
Address			
Customer			
Address			

Record this information at the time that warranty registration form is completed and returned to **Load King**.

## 50-155 M & U

### Introduction

### Crane Limited Product Warranty



## Crane Limited Product Warranty

**Load King LLC** ("Load King") warrants to the original Buyer its new Products will be free, under normal use and service, of any defects in material or workmanship for a period of (i) two years (24 months), or (ii) 2,000 hours of operation. In addition, the warranty period is five years (60 months) for structural crane weldments (boom section, jib, outrigger beam, subbase, frame, mounting anchors, mast, turntable). Each of those aforementioned periods shall commence at the date of initial installation or commission; provided, however, those periods, in the case of a distributor of Load King, shall commence no later than six (6) months after the date of shipment by Load King. Parts fitted during a warranty repair will take on the remaining warranty time period only. The foregoing warranties shall be honored provided that Load King receives written notice of the defect within thirty (30) days of its discovery, but in no event later than fifteen (15) days after the expiration of the applicable warranty period, and it has been established that (i) the Product has been maintained and operated within the limits of rated and normal usage and in strict compliance with Load King's operating and maintenance manuals, (ii) the defect did not result in any manner from the intentional or negligent action, inaction or abuse by Buyer or any third party, and (iii) in the case of structural warranty, all annual inspections have been completed by an authorized Load King service center. If it cannot be established that conditions (i), (ii) and (iii) above have been met, then this Warranty shall not cover the alleged defect.

If requested by Load King, the defective Product must be returned to Load King, or other location designated by Load King, for inspection. Load King reserves the right to review the Product's maintenance procedures to determine if any alleged defect is covered under this Warranty. Delivery inspection forms are required for warranty validation and processing.

Load King's obligation and liability under this Warranty is expressly limited to, at Load King's sole option, repairing or replacing, with new or remanufactured parts or components, any part, which appears to Load King upon inspection to have been defective in material or workmanship. Replacement parts will be provided to Buyer subject to Load King's current warranty claim handling processes. All Products replaced under this Warranty become the property of Load King.

Accessories, assemblies and components included in the Product, which are not manufactured by Load King, are subject to the warranty of their respective manufacturers. Load King does not provide any warranty and Load King specifically disclaims any liability relating to the boom-truck carriers; however, Purchaser may be entitled to the respective boom-truck carrier OEM's pass-through warranty (subject to any registration requirements).

This Warranty shall be null and void if parts (including wear parts) other than genuine Load King Parts are used in or attached to the Product or if serial numbers have been altered, defaced, or removed with respect to Load King's Products or if the Product has been altered without Load King's written agreement.

#### **LOAD KING MAKES NO OTHER WARRANTIES, EXPRESS OR IMPLIED, AND MAKES NO WARRANTIES OF MERCHANTABILITY OR FITNESS FOR ANY PARTICULAR PURPOSE.**

No employee or representative is authorized to modify this Warranty unless such modification is made in writing and signed by an authorized officer of Load King.

This warranty is continuous for the above stated periods, and "stopping and restarting" such periods ("stop and go") is not accepted by Load King.

Load King's obligation under this Warranty shall not include the items listed below as "Items not covered by this Warranty."

**NO TRANSFERABILITY OF THIS WARRANTY:** This Warranty is limited to Buyer or, if sold through a distributor of Load King, to the first End User of the Product, and is not assignable or otherwise transferable without the written agreement of Load King.

#### **ITEMS NOT COVERED BY THIS WARRANTY**

The following items are not covered under this Warranty (the following list is not exhaustive):

- Normal maintenance, adjustments, maintenance parts or wear parts, including without limitation wear pads, seals, gaskets, hoses, friction plates, glass, clutch and brake linings, filters, wire rope, exterior coatings, proper tightening of bolts, nuts and fittings, adding or replacing of fluids, filters, breathers, belts, nozzles, adjustments of any kind, service supplies such as hand cleaners, towels and lubricants, inspections, diagnostic time, travel time, or labor.
- Products sold by any individual, corporation, partnership or any other third party that is not authorized by Load King to distribute the Product.
- Damage or defect caused by, or other costs related to, work performed by personnel not authorized by Load King to service or repair the Product.
- Damage or defect caused by operation of the Product by personnel or users not authorized or instructed or trained to operate the Product.
- Costs including, without limitation, travel, freight and labor, resulting from shipment or transfer of the Product into or use in a region not covered by Load King's service network.
- Costs including, without limitation, travel, freight and labor, related to the disassembling and assembling of any equipment with respect to a defective Part integrated in such equipment not covered by Load King's warranty.
- Damage or defect resulting from improper storage, weathering, lack of use, demonstration use, or use for transportation of corrosive chemicals.

## 50-155 M & U

### Introduction

### Crane Limited Product Warranty



- Damage or defect resulting from operation of the Product after a failure, damage or defect noticeably occurred, or damage or defect caused by worn parts or fluids.
- Damage or defect caused by operation or storage of the Product under extreme weather or geographical conditions, including without limitation, fires, freezing, floods, other natural disasters and abnormal conditions of temperature, moisture, dirt or corrosive matter, without the written agreement of Load King.
- Damage or defect caused by non-compliance with Load King's campaign bulletins, product safety and service releases.
- Damage or defect caused by carrier handling. Any such claim for damage should be filed immediately with the respective carrier.
- Cost including, without limitation, travel, freight and labor, resulting from the lack of Buyer or the user of the Product to comply with their obligations under this Warranty.
- Damage or defect resulting from or costs related to acts of God.

**THIS WARRANTY IS EXPRESSLY IN LIEU OF AND EXCLUDES ALL OTHER WARRANTIES, REPRESENTATIONS AND CONDITIONS, EXPRESS OR IMPLIED AND ALL OTHER STATUTORY, CONTRACTUAL, TORTIOUS AND COMMON LAW OBLIGATIONS OR LIABILITY ON LOAD KING'S PART ARE HEREBY EXPRESSLY EXCLUDED TO THE MAXIMUM PERMITTED BY LAW. THERE ARE NO WARRANTIES THAT EXTEND BEYOND THE LIMITED WARRANTY CONTAINED HEREIN.** Load King neither assumes nor authorizes any other person to assume for Load King any other liability in connection with the sale of Load King's Product. In the event that any provision of this Warranty is held unenforceable for any reason, the remaining provisions shall remain in full force and effect.

**IN THE EVENT OF ANY BREACH OF THE WARRANTY BY LOAD KING, LOAD KING'S LIABILITY SHALL BE LIMITED EXCLUSIVELY TO THE REMEDIES (AT LOAD KING'S SOLE OPTION) OF REPAIR OR REPLACEMENT OF ANY DEFECTIVE PRODUCT COVERED BY THE WARRANTY. NOTWITHSTANDING ANYTHING CONTAINED IN THIS WARRANTY TO THE CONTRARY, LOAD KING SHALL NOT BE LIABLE FOR AND SPECIFICALLY DISCLAIMS ALL INDIRECT, CONSEQUENTIAL, INCIDENTAL OR OTHER DAMAGES OR LOSSES WHETHER OR NOT ADVICES OF THE POSSIBILITY THEREOF.** Nothing in this Section shall operate to exclude Load King's liability for death or personal injury when directly related to Load King's negligent act or omission.

**PAGE INTENTIONALLY LEFT BLANK**

## 50-155 M & U

Specifications

Features



## Specifications

The **Load King** Stinger 50-155 Boom Truck is unique to the boom truck industry. With a 50-ton (100,000 lbs.) lifting capacity, the telescopic boom reaches up to a max tip height of 165 feet with a double-keel boom offering a maximum boom length of 155 feet. With the addition of the 49 foot jib, the Stinger 50-155 will reach up to 215 feet maximum tip height.



## Features

50 U.S. tons @ 10 ft.

155 ft. Full Power Main Boom

165 ft. Tip Height (Boom Only)

32-49 ft. Optional Two-Piece Jib, Offsettable 0,15, or 30 Degrees

215 ft. Maximum Tip Height with 49 ft. Jib

Hydraulic-Tilting Operator Cab (0-18 Degrees)

Electronic Load Moment Indicator (LMI)

LK-1 Control System

## Crane Measurements

### 50-155

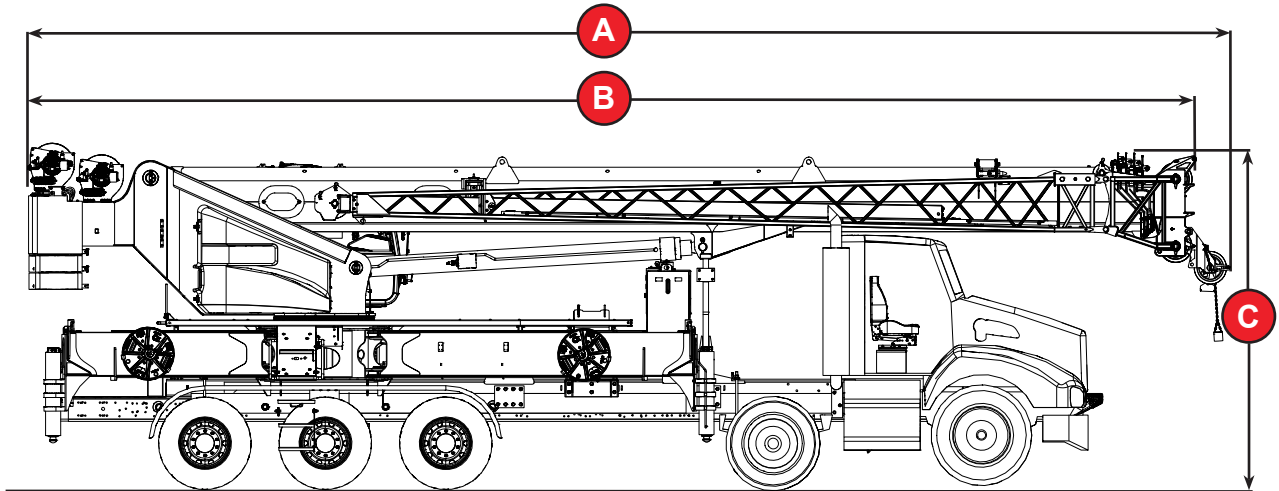

### Outrigger Fully Extend

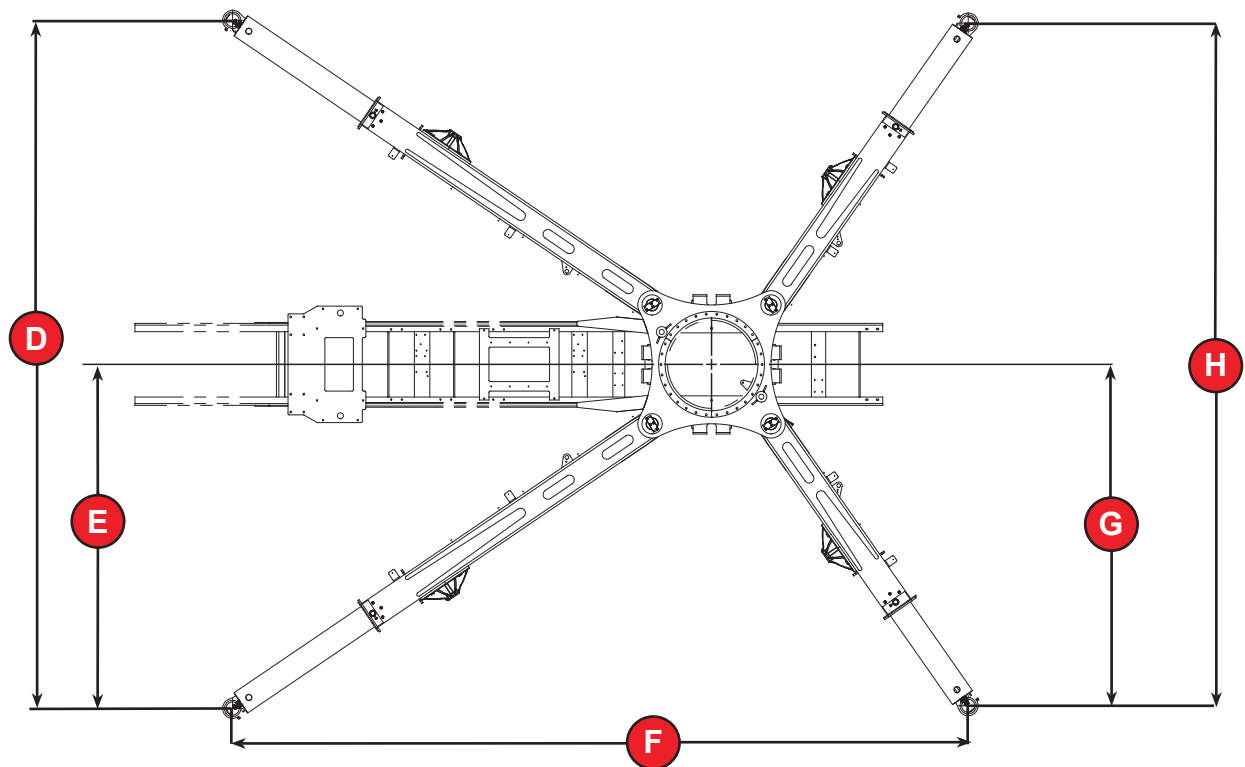

**Outrigger Mid Position**

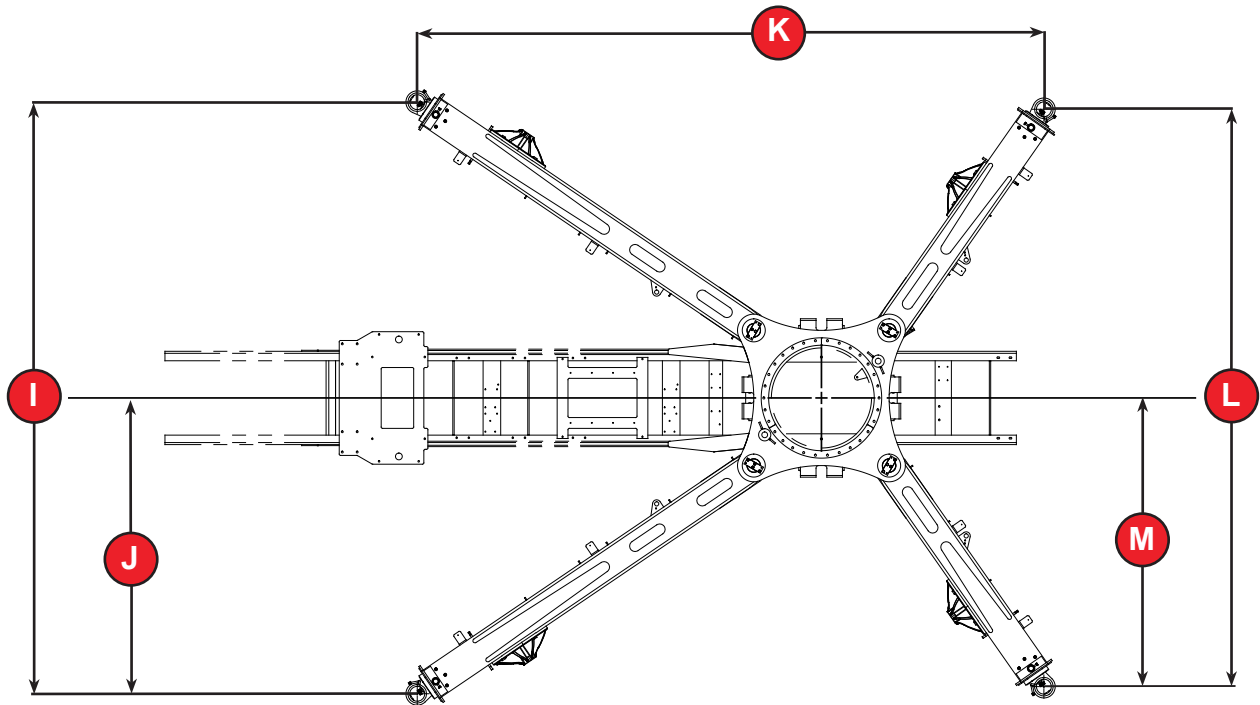

**Outrigger Fully Retracted**

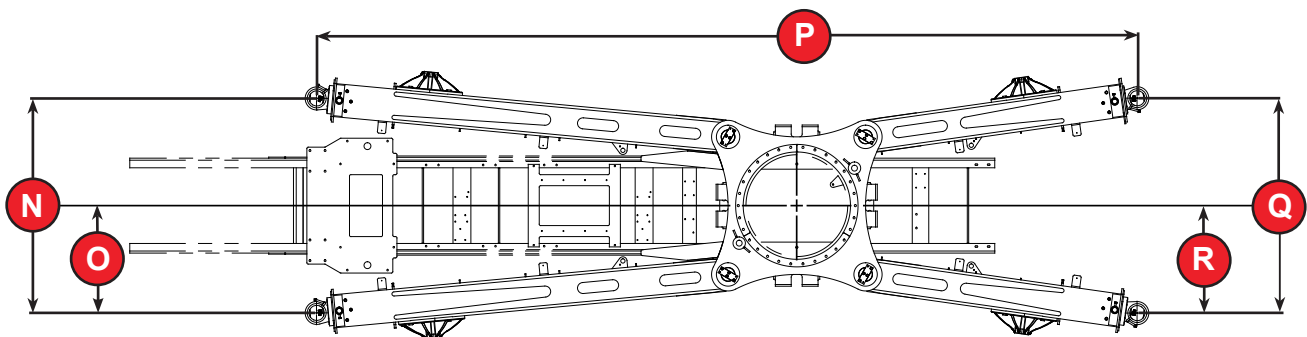

## 50-155 M & U

### Specifications Crane Measurements



All dimensions listed are approximate, depending on the full dimensions of the chassis on which the crane body is mounted. If exact dimensions are required, contact your **Load King** service representative.

Reference Letter	Dimensions
A	45'-9"
B	44'-4"
C	13'-1"
D	24'-2"
E	12'-2"
F	25'-11"
G	11'-13"
H	11'-12"
I	18'-4"
J	9'-3"
K	19'-5"
L	17'-11"
M	8'-12"
N	6'-7"
O	3'-4"
P	24'-12"
Q	6'-6"
R	3'-3"

## 50-155 M & U

Specifications

Wire Rope Specifications



### Wire Rope Specifications

Compact 35 Rotation Resistant Rope

Length - 500 ft.

Size - 5/8" diameter (16 mm)

Strand pattern - 35 x 7 combined (filler wire type)

Type of core - Wire Strand Core (WSC)

Direction and type of lay - Right lang lay

Finish - Bright finish/Galvanized finish

Grade - 2160 (EEIPS)

Minimum breaking strength - 56,400 lbs.

Approximate weight - 0.88 lbs/ft.

Although other types of rope will function with the **Load King** crane, **Load King** recommends the use of rotation resistant rope on the 50-155 crane. Before using other types of rope, consult **Load King** engineering via your service representative.



When using rotation resistant rope, the working load must not exceed one-fifth (20%) of the rated breaking strength. The following are the retirement criteria: two broken wires in six rope diameters or four broken wires in thirty rope diameters. See [Wire Rope Inspection](#).

## 50-155 M & U

### Specifications

### Wire Rope Specifications

## Hydraulic Pumps and Function Speeds

The **Load King** 50-155 series of cranes use one (1) variable hydraulic displacement piston pump and two (2) hydraulic gear pumps. To produce the proper amount of flow to run the hydraulic functions at full speed, the engine must run at 1650 RPM.

The required engine speed is very important when testing the hydraulic unit speeds, and checking or handling maximum loads. Keep in mind that the pump and engine speeds are not the same due to PTO ratio.

When troubleshooting a unit suspected of having slow functions, it is important to know if the pumps are receiving the proper RPM and how much flow to expect from the pumps. The charts below will help accurately test the flow of the pumps, as well as determine the proper speed of the functions of the unit. Oil temperatures below 140° F (60° C) may cause slower function operation.

### 3 Pumps System Flows

Pump Flow @ Pump RPM	Function
81 GPM @ 2200	Winch and Boom
21 GPM @ 2200	Swing and Outriggers
21 GPM @ 2200	HVAC

### Function Speeds

The chart below provides an estimate of the speeds that can be expected from the **Load King** Boom Truck. All speeds listed are for one complete cycle. For example, the swing time is 29 seconds for one full 360° rotation.

Function	Approximate Duration
Swing 360	29 seconds
Boom Extend	80 seconds
Boom Retract	70 seconds
Boom Raise	60 seconds
Boom Lower	50 seconds
Counterweight Raise	22 seconds
Counterweight Lower	29 seconds
Winch (Normal Speed)	222 FPM (3rd Layer)
Winch (Hi Speed)	444 FPM (3rd Layer)

Outrigger Swing (Times denote the activation of two cylinders at the same time)	10 seconds - Extend	12 seconds - Retract
Outrigger Beam (Times denote the activation of two cylinders at the same time)	9 seconds - Extend	13 seconds - Retract
Outrigger Jack (Times denote the activation of two cylinders at the same time)	16 seconds - Extend	24 seconds - Retract

## Safety

### Owners, Users, and Operators

**Load King** appreciates your choice of our machine for your application. Our number one priority is user safety, which is best achieved by our joint efforts. We feel that you make a major contribution to safety if you, as the equipment users and Operators:

- Comply with OSHA, federal, state, and local regulations.
- Read, understand, and follow the instructions in this and other manuals supplied with this machine.
- Follow safe work practices.
- Only have trained and competent Operator's, directed by informed and knowledgeable supervision, running the machine.



OSHA prohibits the alteration or modification of this crane without written manufacturer's approval. Use only factory-approved parts to service or repair this unit.

If there is anything in this manual that is not clear or you believe should be added, please send your comments to **Load King** Cranes, 7701 Independence Ave, Kansas City, MO 64125; or contact us by telephone at Parts: (816) 241- 8387 Service: (833) 281-7911.  
Email: [info@loadkingmfg.com](mailto:info@loadkingmfg.com)

Many aspects of crane operation and testing are discussed in standards published by the American National Standards Institute. These standards are updated on an annual basis with addenda, that are sent by ASME to the original purchasers of the standard. **Load King** recommends owners purchase and refer to the following standards.

ANSI/ASME B30.5 - Mobile and Locomotive Crane (latest version)

These standards can be purchased from:

American Society of Mechanical Engineers  
Two Park Avenue  
New York, NY 10016-5990  
800-843-2763 (U.S./Canada)  
001-800-843-2763 (Mexico)  
973-882-1170 (outside North America)

Email:  
[CustomerCare@asme.org](mailto:CustomerCare@asme.org)  
[www.asme.org](http://www.asme.org)





## 50-155 M & U

Safety

Safety Definitions Used in This Manual

### Safety Definitions Used in This Manual

The following table describes text and symbols used to highlight important information.

Signal Word	Symbol	Explanation
<b>DANGER</b>		Danger indicates a hazardous situation which, if not avoided, will result in death or serious injury.
<b>WARNING</b>		Warning indicates a hazardous situation which, if not avoided, could result in death or serious injury.
<b>CAUTION</b>		Caution indicates a hazardous situation which, if not avoided, could result in minor or moderate injury.
<b>READ</b>		Read is used to alert readers of information to be read on machinery.
<b>NOTE</b>		Note is used for a tip or suggestion to help readers carry out a procedure successfully.

#### Safety Sign Maintenance

- Keep Operator's safety in mind at all times.
- Use mild soap and water to clean safety signs.
- Do not use solvent-based cleaners because they will damage the safety sign material.
- Replace any missing or damaged safety signs or decals.

## Safety Guidelines



These safety rules must be followed. All personnel are required to read and understand the Operator's Manual as there are instructions which are detailed specific to this machine.

## Personal Protection Equipment

Before beginning operation, service, or maintenance, conduct a hazard assessment to determine appropriate personal protective equipment for the working conditions and the operating environment. For more information refer to the applicable OSHA 1910.132 standards, ANSI standards, federal, state, local, and job site regulations.

### Common Types of PPE



**Safety Glasses** – Impact resistant lenses offering limited protection for the user's eyes from flying debris.



**Ear Plugs** – A device that is inserted into the ear canal to protect the user's hearing from loud noises or the intrusion of foreign bodies and dust.



**Hard Hat** – A helmet used to protect the user's head from injuries obtained from falling objects and debris.



**Leather Gloves** – Gloves used to protect the user's hands from minor cuts and other injuries.



**Safety Boots** – Boots designed to protect the user's feet from various types of injury such as cuts, puncture wounds, or crushed toes.

## 50-155 M & U

Safety

Workplace Safety

### Workplace Safety

#### Handling Personnel

Cranes can only be used to lift people when it is the least hazardous way to do the job.  
(See OSHA 1926.1431, 1926.550g, and ASME/ANSI B30.23.)

#### Training and Knowledge

- Safe operations must always be the Operator's most important concern.
- This crane must only be operated by trained personnel, who have demonstrated their ability to do so safely.
- Comply with the requirements of current Occupational Safety and Health Administration (OSHA) standards, the current ASME B30.5 (latest edition).
- Read and understand all safety signs and warnings.
- Read and understand the Load Rating Charts.
- By understanding the Load Rating Charts, the Operator can determine what the crane can safely lift before attempting the actual lift.
- The Operator must understand crane signals and take signals only from designated signal persons; however, the Operator must obey the stop signal from anyone.

#### Operator's Responsibilities

- Read and understand the Operator's Manual.
- Ensure the machine is in proper order and that all operational aids and warning signals are functional before operating.
- Keep the machine clean, including all instrumentation, windows, lights, and other glazed surfaces.
- Remove all oil, grease, mud, ice, and snow from walking surfaces.
- Store all tools, rigging, and other necessary items in the toolbox.
- Do not lift a load without referring to the Load Rating Charts manual located in the Operator's cab.
- Know the load to be lifted.
- Be alert, physically fit, and free from the influences of alcohol, drugs, or medications that might affect the Operator's eyesight, hearing, or reactions.
- Keep people, equipment, and material outside of the work area.
- Signal person(s) must be used when the Operator's vision is blocked or when working in hazardous areas such as near power lines or people.
- Keep a fully charged fire extinguisher and first aid kit in the Operator's cab at all times and be familiar with the use of these items.
- Be aware of the location of other machinery, vehicles, personnel, and other obstacles in the work area.
- Do not allow personnel on the machine Operator's platform while the machine is in operation.
- Make sure everyone is clear of the work area before moving the hook, boom, load, or outriggers.
- Start and stop movements smoothly and swing at speeds that will keep the load under control.

- Keep at least three full wraps of wire rope on the winch drum when operating.
- Use tag lines to keep loads under control when feasible.
- Keep the load as close to the ground as possible.
- Use shortest boom length required to complete job.
- Do not leave a running machine unattended or load suspended.
- Use the outriggers in accordance with requirements of the Load Rating Chart and Operator's Manuals.

### Signal Person's Responsibilities

- Standard crane signals must be used and understood.
- Assist the Operator in safe and efficient operation of the crane, without endangering people or property.
- Have a clear understanding of each lift to be made.
- Signal persons must place themselves where they can be clearly seen, where they can safely observe the entire operation, and out of harm's way should something unexpected happen.

### Responsibilities of All Crew Members

- Unsafe conditions and/or practices must be corrected.
- Obey all warning signs.
- Watch out for their own safety and the safety of others.
- Know and understand proper machine erection and rigging procedures.
- Alert the Operator and signal person to hazards, i.e., power lines, unstable ground.

### Management Responsibilities

- Operator's must be competent, physically fit, and licensed if required.
- The Operator, signal persons, and riggers must be trained on correct crane operations and usage.
- The Operator and signal persons must know the standard crane signals.
- The job site must have a supervisor present that is responsible for site safety.
- Crew members must be given specific safety responsibilities and be instructed to report any unsafe conditions to the site supervisor.
- Supply the weight and the characteristics of all loads to be lifted to the Operator.
- Verify that all crew members are familiar with OSHA, ANSI B30.5 requirements, state, and local job site requirements, as well as the instructions in manuals, and all other applicable requirements.

## 50-155 M & U

### Safety

#### Workplace Safety

#### Planning the Job

- Have a clear understanding of the work to be done.
- Consider all hazards at the job site.
- Know what crew members are needed to complete the job.
- Assign job responsibilities.
- Appoint a competent signal person.
- Establish how the signal person will communicate with the Operator.
- Know the weight and the characteristics of the loads to be lifted.
- Utilize rigging and other equipment to complete the job safely.
- Establish how equipment can be safely transported to the job site.
- Determine how the load will be rigged.
- Determine the lift radius, boom angle, and the rated lifting capacity of the crane.
- Pre-plan the course of each lift to determine the best route to reach the load's target destination.
- Identify the location of gas lines, power lines, or other structures and determine if the crane or structures needs to be moved.
- Ensure that the supporting surface is strong enough to support the machine and load.
- Establish special safety precautions, if necessary.
- Consider the weather conditions.
- Keep unnecessary people and equipment away from the work area.
- Position the machine to use shortest boom and radius possible.

#### Operator Prelift Check

- Check the machine logbook, to see if periodic maintenance and inspections have been performed.
- Ensure that necessary repairs have been completed.
- Inspect wire rope for damage such as kinks, broken wires, or crushed sections.
- Ensure that no unauthorized field modifications have been made to the crane.
- Check for air and hydraulic oil leaks.
- Check that all controls are in the neutral position before starting engine.
- After starting the engine, check all gauges and indicators for proper readings.
- Test all controls in the cab or control station, such as swing, boom extend/retract/up/down, outriggers extend/retract and throttle.
- Check brakes and clutches.
- Check hoist brakes by lifting a load a few inches off the ground and holding it.

## Operator Aids Check

Ensure that the listed items are in place and operational:

- Boom angle indicator
- Backup alarms
- ATB devices
- Overload protection, load indicators, and Load Moment indicator (LMI)

## Operation Overload Protection

- Know the weight and characteristics of all loads to be lifted.
- Place the boom lifting point directly above the load when lifting.
- The load radius will increase when the load is lifted due to boom deflection. To compensate for the boom deflection, maintain the radius by raising the boom.
- Know the weight of the hook and rigging, the boom and/or jib length, parts of line and the work area.
- Use next lower rated capacity when working at boom lengths or radius within the range on the rated lifting capacity chart.
- Do not lift a load without knowing whether it is within the rated capacity.
- Do not operate with anything other than recommended counterweight. Unauthorized reduction or additions of counterweights constitute a safety hazard.
- Do not lift loads if winds create a hazard. Lower the boom if necessary. Refer to the Load Rating Chart and the Operator's Manual for possible restrictions.
- Avoid side-loading the boom.
- Do not allow the load or any other object to strike the boom.
- Loads shall be freely suspended.
- Do not use the LMI to weigh the load.

## Operation Setup

When preparing the crane for operation, ensure that the load-bearing ground surface is strong enough to support the crane, including the load to be lifted.

Ensure that the crane is level for all operations. Check frequently, and re-level the crane if necessary.



Ensure that personnel and the public maintain a safe distance from rotating cranes. Place barricades to restrict access to the crane area. Verify that all areas are clear prior to swinging.

## 50-155 M & U

### Safety

#### Workplace Safety

#### Power Line Safety

- Determine whether there are power lines in the area before starting any job. Only operate around power lines in accordance with federal, state, and local regulations, as well as ASME B30.5 (latest edition).
- Use a signal person when working around power lines as established by the utility Owner/Operator or registered professional engineer. This should be someone who is a qualified person with respect to electrical power transmission and distribution per OSHA regulation 1926.1408 and 1926.1409.
- Do not remove materials from under power lines with a crane if the boom or other components of the crane will come into contact with the power lines.
- No part of the crane or the load should contact, or violate the minimum allowable clearance required for operation of the crane near electrical lines. For further clarification, see the following table:

<b>Maintain Required Clearance from Power Lines</b>	
<b>Line Voltage</b>	<b>Required Clearance</b>
0 to 50 kV	10 ft. (3.0 m)
500 to 200 kV	15 ft. (4.6 m)
2000 to 350 kV	20 ft. (6.1 m)
350 to 500 kV	25 ft. (7.6 m)
500 to 750 kV	35 ft. (10.7 m)
750 to 1000 kV	45 ft. (1.37 m)
Greater than 1000 kV	Determine specified clearance after consultation with utility Owner/Operator.

Before operating the machine, contact the electric power line owner to disconnect, move, or insulate power lines.

- If contact with power lines occurs, stay on the crane until the boom is cleared or until the electrical current is turned off.
- If contact with power lines occurs, keep all personnel away from the crane. If you must leave the crane, jump with both feet together, completely clearing the machine.

## **Travel**

- Care must be taken when the crane is driven, whether on or off the job site.
- Pre-plan the path of travel to determine the best route to the destination.
- A signal person shall be utilized when the Operator's vision is blocked or obstructed during traveling operations.
- Maintain awareness of people, power lines, low or narrow clearance, bridge or road load limits, steep hills, or uneven terrain.
- Place the boom in the stowed position.
- Inflate the tires to the specified pressure.
- Drive slowly and avoid sudden stops and starts.
- Use the seat belt during all transit and travel.
- Ensure that ground surfaces can support the weight of the machine and any stored load.
- Set the parking brake when parking the machine.

## 50-155 M & U

Safety

Effects of Wind Conditions

### Effects of Wind Conditions

#### Lifting Constraints

The crane can be used safely by following the values given in the load capacity tables up to a wind speed of 20 mph (32 km/h) on a load surface of 11.7 ft<sup>2</sup>/ton (1.1 m<sup>2</sup>/tonne).



Check the weather forecast and monitor wind speed conditions near the job site. When wind speed exceeds 20 mph (32 km/h), derating of the crane's lifting capacity is required. See the Operating Instruction section of the crane's [Maximum Load and Boom Angle Charts](#).

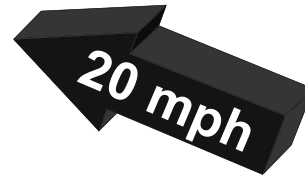
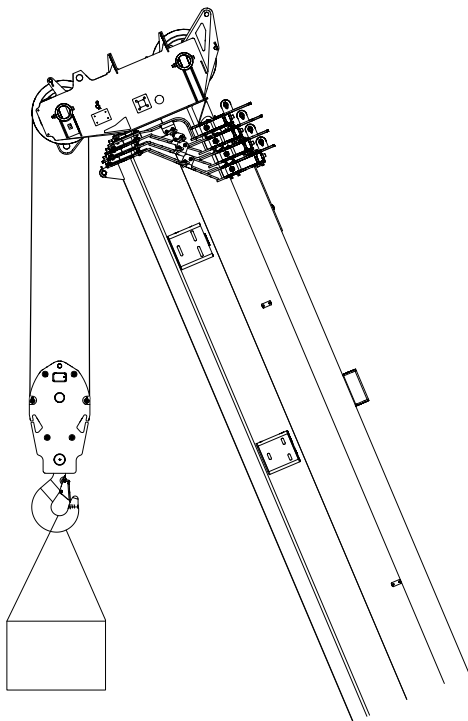

**Wind**

**Maximum Operational Wind Speed Before Derating of Lifting Capacity is Required.**



Pay attention to the wind speed values in table below in relation to the information in the Operating Instruction section of the [Maximum Load and Boom Angle Charts](#). Any governmental regulations applicable to the job site must also be observed.

Wind Force		Wind Speed		Observable Effect on Nature to Estimate Wind Speed
Scale	Terms Described	mph	km/h	
0	Calm	0 - 1	1	Calm; smoke rises vertically.
1	Very Light	1 - 3	1 - 5	Wind direction indicated by the smoke and not by the banner.
2	Light Breeze	4 - 7	6 - 11	The wind can be felt on the face, the leaves rustle, the banner moves.
3	Gentle Breeze	8 - 12	12 - 19	Leaves and small branches move, banners lift.
4	Mild Breeze	12 - 18	20 - 28	The wind raises dust and leaves. Branches move.
5	Fair Breeze	18 - 24	29 - 38	Small bushes sway. Wave crests form on the sea.
6	Strong Breeze	24 - 31	39 - 49	Large branches sway.
7	Strong Wind	31 - 38	50 - 61	All the trees sway.

### Lightning Storm

When lightning is striking in the vicinity of the crane, the Operator should not attempt the following procedures:

- Entering the Operator’s cab or attempting to climb onto the carrier, superstructure, or boom assembly.
- If on the machine, do not try to get off the machine.

If personnel are in the Operator’s cab during an electrical storm, they should stay in the cab. If personnel are on the ground during a storm, they should avoid the vicinity of the machine.

## 50-155 M & U

### Safety

#### Temporary Interruption of Crane Operations

### Temporary Interruption of Crane Operations

As a general rule, if it is not possible to maintain sufficient control over a rigged crane, the boom and the equipment shall be taken down. The boom and rigging should be stowed if the crane's operations are interrupted and may be left unsupervised.

The following instructions are valid for every mobile crane, regardless of type, configuration, the rigging mode or the environment:

- The crane shall be left in the smallest, most stable, valid operational configuration that the job site practically allows; this includes parameters such as boom angle, slewing orientation, and jib angle.
- The engine shall be switched off.
- All control levers shall be put into the neutral or in a locked position.
- The heating system should be switched off.
- The crane shall be secured and the cabins shall be locked to prevent unauthorized use or unintended movement.
- Close all control panels that are fitted with a lock/key when they are not in use.
- Depending on the crane type, mobile control panels connected to the crane with cables shall be removed when they are not in use.
- The radio remote control, if it is available, shall be kept in a safe place to prevent unauthorized use or unintended movement. Make sure that the batteries are recharged.
- The parking brake of the crane chassis shall be applied.
- The transmission gear shall be set to neutral.
- The wheels shall be secured with chocks, the slew brake applied, and the main boom secured.

An urgent situation may arise such that the crane must be left unattended while the boom is in an extended or telescoping position. Should this occur, job site conditions may not allow the boom and jib to be fully lowered to the ground. Under these conditions, a qualified Operator must determine an appropriate configuration in which the crane may be safely left unattended. This qualified Operator must be familiar with all aspects of the situation, including the job site configuration, the limitations present, and other pertinent considerations. The following instructions must also be followed:

- Create an emergency action plan that includes instructions on how to safely stow the crane. The plan must take into consideration the amount of space needed around the crane to dismantle or lower the boom, jib, or other equipment. This plan should take into account natural disasters (e.g., tornado, flood, fire) as well as industrial accidents, chemical exposure, public acts of violence, or other incidents as listed at the beginning of this document.
- The crane shall not be left with load on the hook.
- All slings or fastening ropes shall be removed from the crane hook.
- The hook block shall be at the highest position so that there is no contact possible between the wire ropes and the boom or other obstacles.
- The crane location and configuration shall not create hazards to road traffic, e.g., risk of collision with surrounding obstacles. This may require a specific risk assessment prior to leaving the crane unattended.

- Check for leakage and unintended (slow) movement on all load-bearing hydraulic cylinders and winches:
  - Outrigger vertical cylinders
  - Boom lifting cylinder(s)
  - Hoist winch
  - Boom extension cylinder(s)
  - Swing brake locking mechanism



Slight movement of hydraulic cylinders can also be due to changing ambient temperature or oil temperature (e.g., due to sun warming or hydraulic oil cooling).

- The weather forecast shall be obtained in advance for the whole period the crane is erected.
  - Changing meteorological conditions, including, but not limited to wind, ice accumulation, precipitation, flooding, or lightning, should be considered when determining the location and configuration of a crane when it is to be left unattended.
  - The crane boom should be lowered before wind speeds exceed the defined values. This may not be possible depending on job site and crane setup.
  - If, due to unforeseen weather conditions, the wind speeds are in excess of the defined values with the boom in the up position, the crane should be secured as best it can and all personnel cleared from the area.
  - The boom may only be lowered if the expected wind speed during the lowering process is less than the wind speed allowed during jib deployment and stowage (assembly and disassembly) according to the wind speed charts.

## Potential Hazards Presented by an Unattended Crane

The following are examples of possible events that could occur while a crane is left unattended; these possible risks shall be taken into account:

- Storms or bad weather; including, but not limited to lightning, wind, rain or flooding.
- Ground giving way due to severe rain, landslides or washout. If the crane was parked and/or supported on icy ground, the ice may melt under the wheels or outrigger supports.
- Slow retraction of the crane's hydraulic cylinders (e.g., outrigger support cylinders, lift cylinders, and/or telescoping cylinders on unpinned telescoping systems) due to changes in ambient temperature, oil temperature, or leakage.
- Vandalism

Any of the hazards listed above may result in the following events:

- The crane may topple over.
- The crane may move.
- Unsafe operational conditions may be created.
- Unauthorized operation of the crane may occur.

## 50-155 M & U

### Safety

#### Potential Hazards Presented by an Unattended Crane

---

### Resuming Crane Operations

Before crane operation is resumed after a period of inactivity/crane being unattended, the Operator is required to check the condition of the crane and its location.

Whenever the Operator has left the cab, the Load Moment Indicator (LMI) settings must be verified and reset.

### Ending Crane Operations

Prior to leaving the crane, the Operator must be certain the crane is in a condition acceptable to be left unattended.

### End of Operations Checklist

1. \_\_\_\_\_ Is the load fully on the ground and unhooked from the crane?
2. \_\_\_\_\_ Is the telescopic boom retracted completely?
3. \_\_\_\_\_ Is the work-site crane boom all the way down and disassembled if necessary?
4. \_\_\_\_\_ Is the parking brake on the crane chassis engaged?
5. \_\_\_\_\_ Is the crane engine off and ignition key removed?
6. \_\_\_\_\_ Is the crane cab locked?
7. \_\_\_\_\_ Is the crane secured from unauthorized use?
8. \_\_\_\_\_ Is the vehicle cab unoccupied?
9. \_\_\_\_\_ Is the vehicle engine off and the key removed?
10. \_\_\_\_\_ Is the vehicle parking brake engaged?
11. \_\_\_\_\_ Are the controls in neutral?

## Lock Out and Tag Out

Occupational Health and Safety Code of Federal Regulations number 1910.147 requires that employers establish and follow a Lock Out and Tag Out procedure and train their employees in that procedure before any employee can operate, service, or maintain any piece of power equipment.

Employers are required to make periodic inspections to confirm that their Lock Out and Tag Out procedures are being followed. They must monitor and update their program on an ongoing basis. Employees are responsible for ensuring that equipment is locked out and tagged out in accordance with the employer's policy.

The contents of a typical Lock Out and Tag Out kit are illustrated in the figure below:

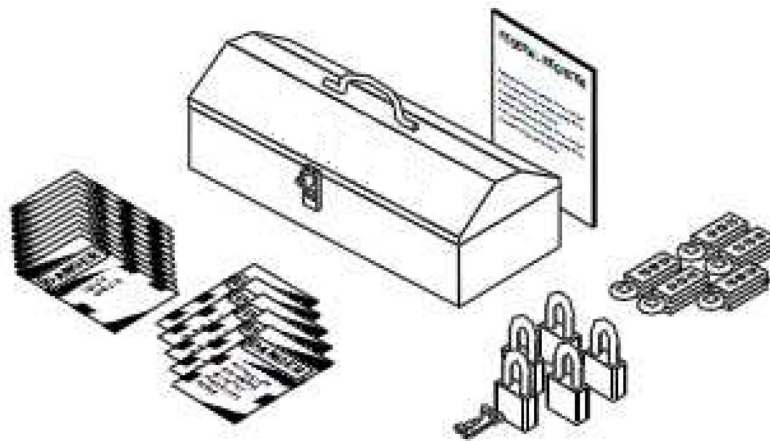

Typical Lock Out and Tag Out Kit

### What is Lock Out and Tag Out?

Lock Out and Tag Out is a procedure that is designed to prevent the unexpected or accidental startup of equipment, and to alert all workers whenever it is unsafe to operate any piece of equipment. When used as intended, Lock Out and Tag Out also protects personnel from energy stored in devices such as springs, accumulators, batteries, or hydraulic systems.

### How to Lock Out and Tag Out

- Install one or more locks to hold the master switch lever in the OFF position.
- If the switch is keyed, turn the key to the **OFF** position and remove the key.
- Disconnect the batteries.
- Regardless of which lockout method is used, place one or more tags on machine control panels, access doors and electrical panels.

### When is Lock Out and Tag Out Required?

- Any time anyone is maintaining, repairing, lubricating, or working on the equipment for whatever reason.
- When the equipment is broken or unfit or unsafe to operate for whatever reason.
- Whenever the equipment is left unattended.

## **50-155 M & U**

Safety

Lock Out and Tag Out

---

### **Who Must Apply a Lock and Tag?**

- Any person working on the equipment.
- Foreman or other person responsible for the work being done.
- If several people are working on a machine at the same time, each person must apply their own lock and tag.

### **When Can a Lock and Tag Be Removed?**

After performing these six steps:

1. All safety guards are back in place.
2. All work is complete and tools are put away.
3. All workers are notified that a lock is being removed.
4. All workers are positioned safely for startup.
5. Controls are positioned for safe startup.
6. The machine is ready for safe operation.

### **Who Can Remove a Lock and Tag?**

- Only the person who applied a lock and tag is permitted to remove them.

The Lock Out and Tag Out rules laid out here are generic. To get instructions for your particular workplace, consult your employer's Lock Out and Tag Out procedure.

## Access/Egress Safety

Access and egress from the crane Operator's cab must always be accomplished using a three-point system. Either two feet and a hand, or two hands and a foot should be in contact with the crane while moving from the ground into the Operator's cab, or moving from the Operator's cab to the ground. **Load King** provides a number of steps, ladders, and handrails allowing three-point access to all areas of the crane in a safe manner.



Access to and from areas of the crane that are not accessible through the provided three-point access devices should only be attempted using OSHA approved access devices (ladders, lifting platforms, scaffolds, or stands) providing three-point access capability.

### Operator's Cab Access/Egress Procedure

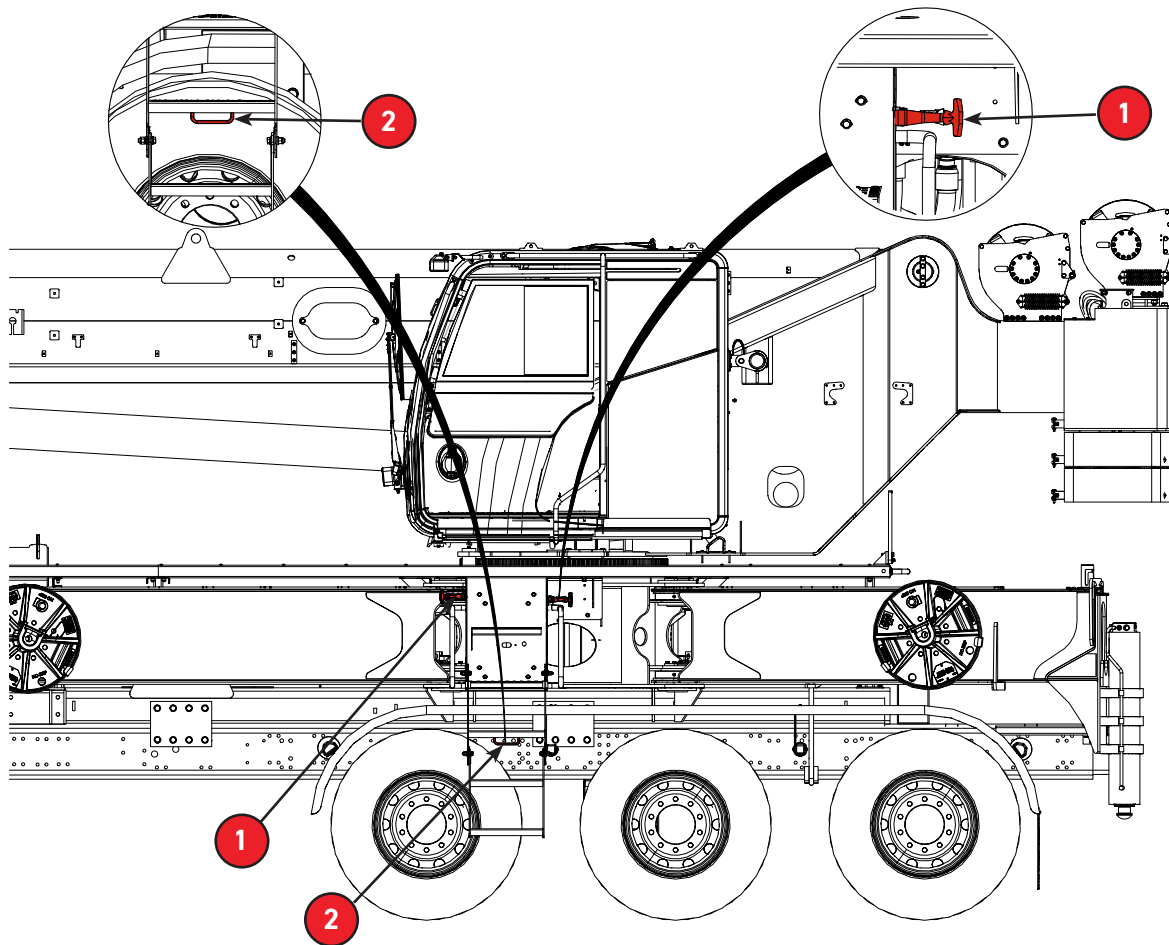

1. Pull rubber T-handle retainer (1) to unlatch in two places to prepare to deploy access steps to Operator's cab.
2. Pull handle (2) towards person and pivot downward for access steps to deploy.
3. Pivot the lower step down.
4. Reverse this procedure to store step assembly before traveling.

## 50-155 M & U

Safety

Access/Egress Safety



Use three (3) points of contact when entering both cabs.

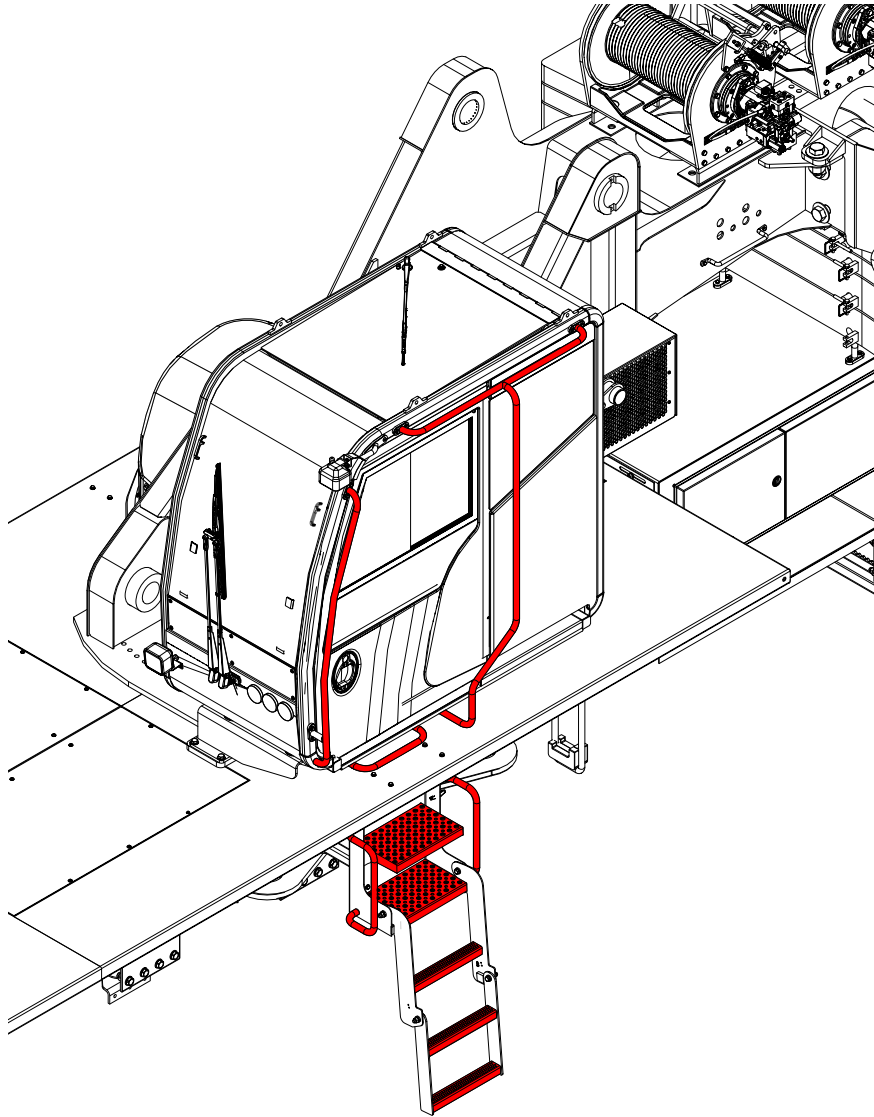

Operator's Cab Steps and Grab Handles with Ladder Deployed

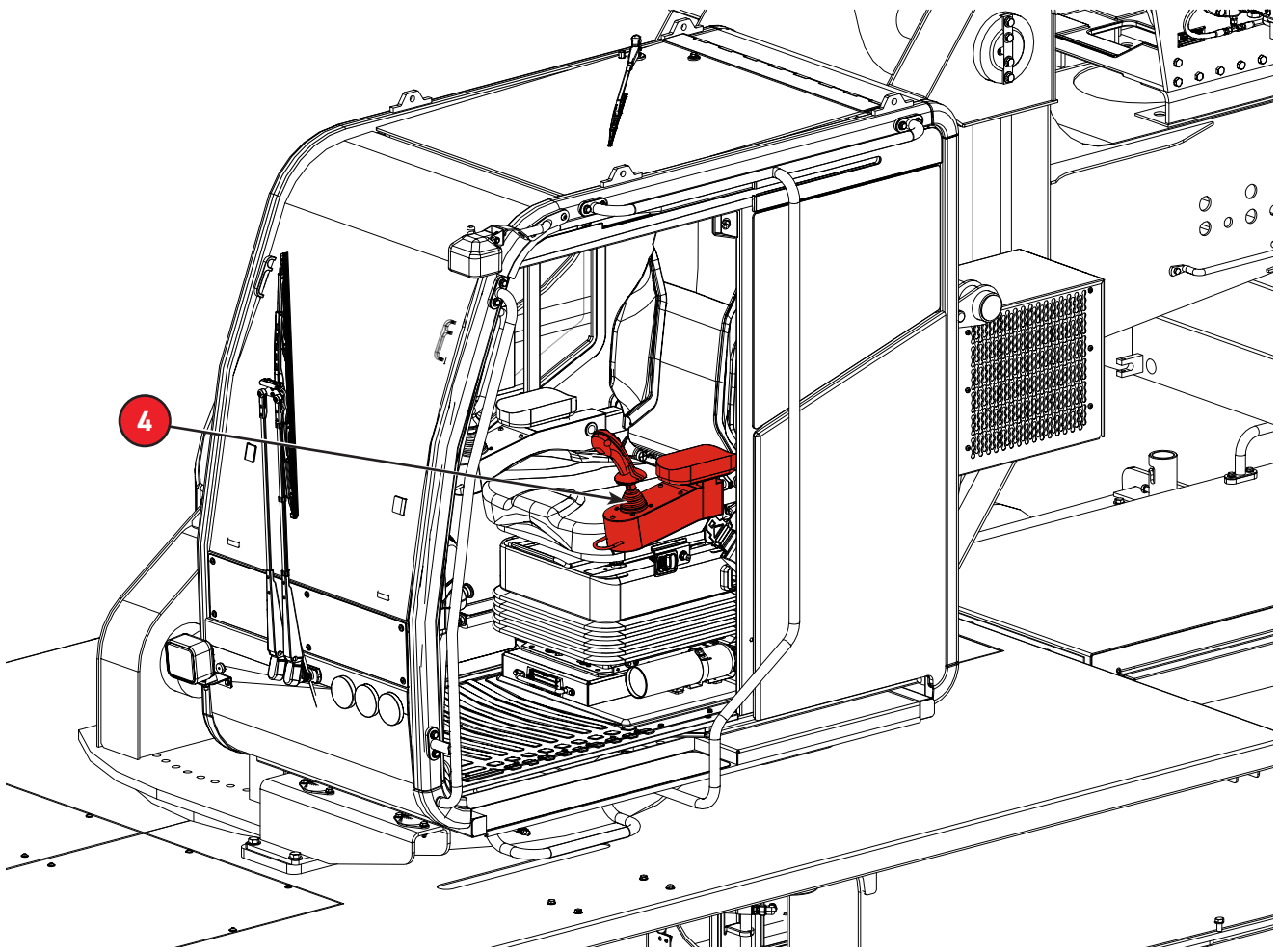

Do not use the console arm lift handle (4), or joystick as a grab handle for entering or exiting the Operator's cab.

## 50-155 M & U

Safety

Personal Safety

### Access/Egress-Rear

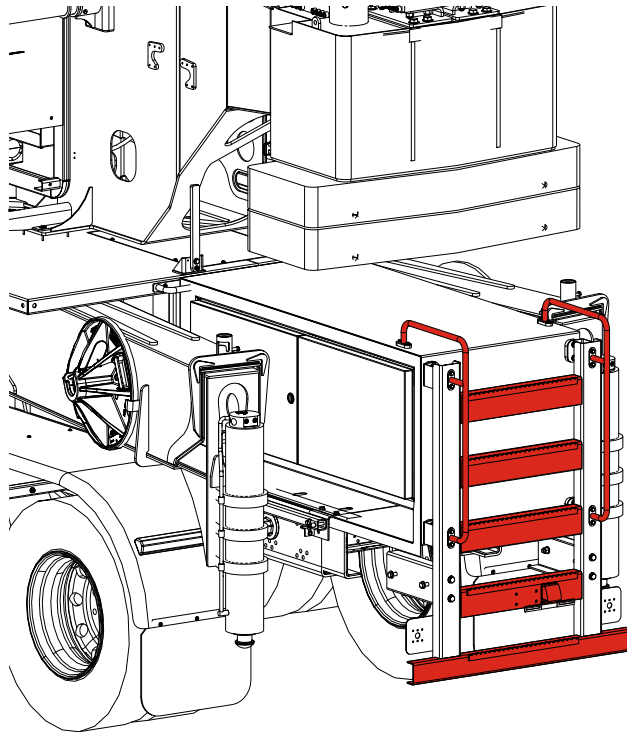

## Personal Safety

### Slip and Fall Prevention

- Wait until the machine has stopped before getting on or off the equipment.
- Do not use controls or steering wheel as hand holds.
- Keep the machine clean and dry. Remove all oil, grease, mud, ice, and snow from walking surfaces.
- Store all tools, rigging, and other items in the toolbox or other appropriate storage.
- Replace all broken ladders or other access system components.
- Keep non-slip surfaces in good condition.
- Do not jump off the machine. Instead, use the hand holds and steps designed for entering and exiting the machine. Face the machine and use three (3) points of contact to ensure personal safety.

## 50-155 M & U

Description of Machine and Controls  
Controls in the Cab

## Description of Machine and Controls

### Controls in the Cab

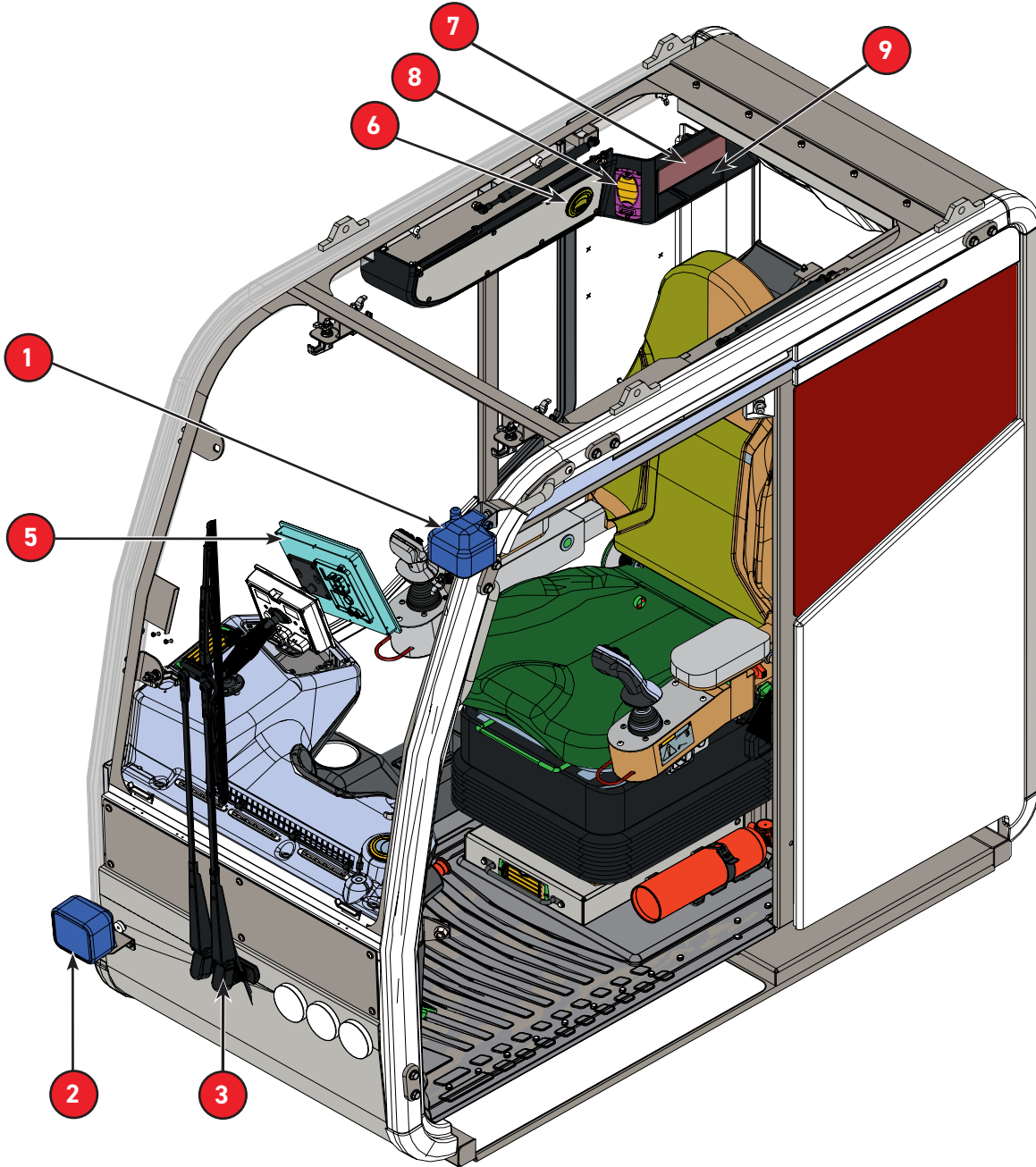

Upper Operator's Cab

1. **Top Work Light** - Press top portion of the rocker switch to activate the roof work light.
2. **Front Work Light** - Press top portion of the rocker switch to activate the front work light.

## 50-155 M & U

### Description of Machine and Controls Controls in the Cab

3. **Windscreen Wiper**
4. **Sliding Door**

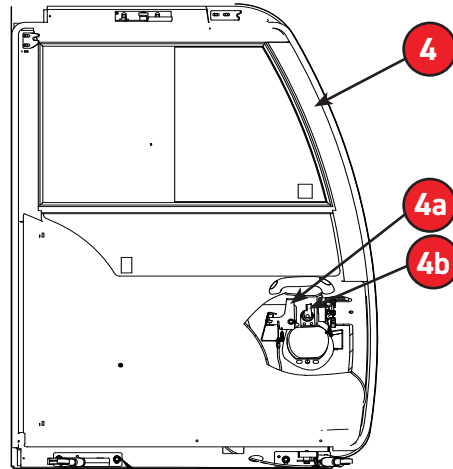

**Sliding Door (Inside Controls)**

- 4a. **Door Release Knob** - Unlocks the cab door and allows entering/exiting the cab.
- 4b. **Door Open Release Knob** - Unlocks the door panel from the fully-open position, allows the door to be closed.
5. **GS Control Screen** - Refer to the section "[Control Screens](#)".
6. **HVAC VENT** - The air vents control flow and direction to direct heat or air conditioning to where it is needed most.
7. **Stereo Radio and CD Player (Optional)**
8. **Dome Light**
9. **Storage Compartment**
10. **Beacon/Rotary Light (Optional)**

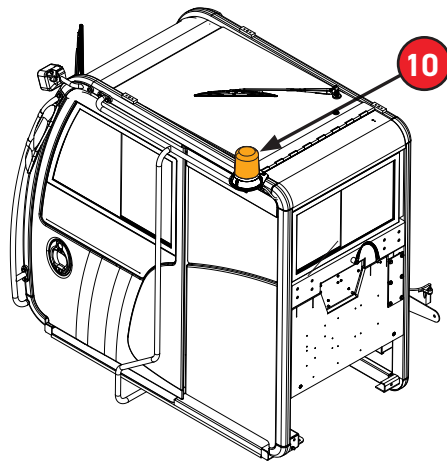

**Beacon/Rotary Light (Optional)**

# 50-155 M & U

Description of Machine and Controls  
Controls in the Cab



11. **Cab Tilt Switch** - Hold down the cab tilt raise switch to tilt the cab from 0° to 20°. Hold down the cab tilt lower switch to reset the cab's tilt angle to 0°.

	<p>Do not activate cab tilt switch while swinging the upper structure. If the cab tilt function is activated while the boom is swinging, the swing may become jerky and load handling will be difficult to control. This erratic swing is because the hydraulic circuit is shared between the cab tilt and the swing functions.</p>
--	---

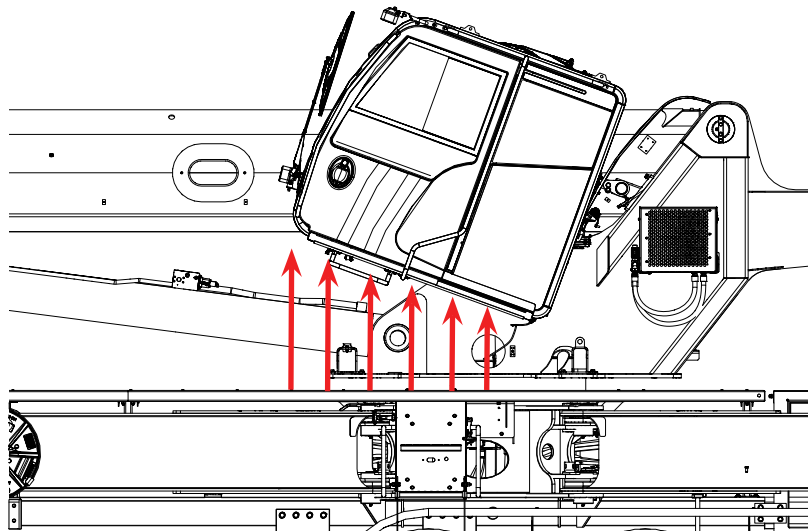

**Keep Clear of This Area During Cab Tilting**

	<p>Keep hands and feet clear of Operator's cab exterior area during tilting. Sound horn before tilting cab to make personnel aware of cab movement.</p>
--	---

## 50-155 M & U

Description of Machine and Controls  
Operator's Seat Controls

### Operator's Seat Controls

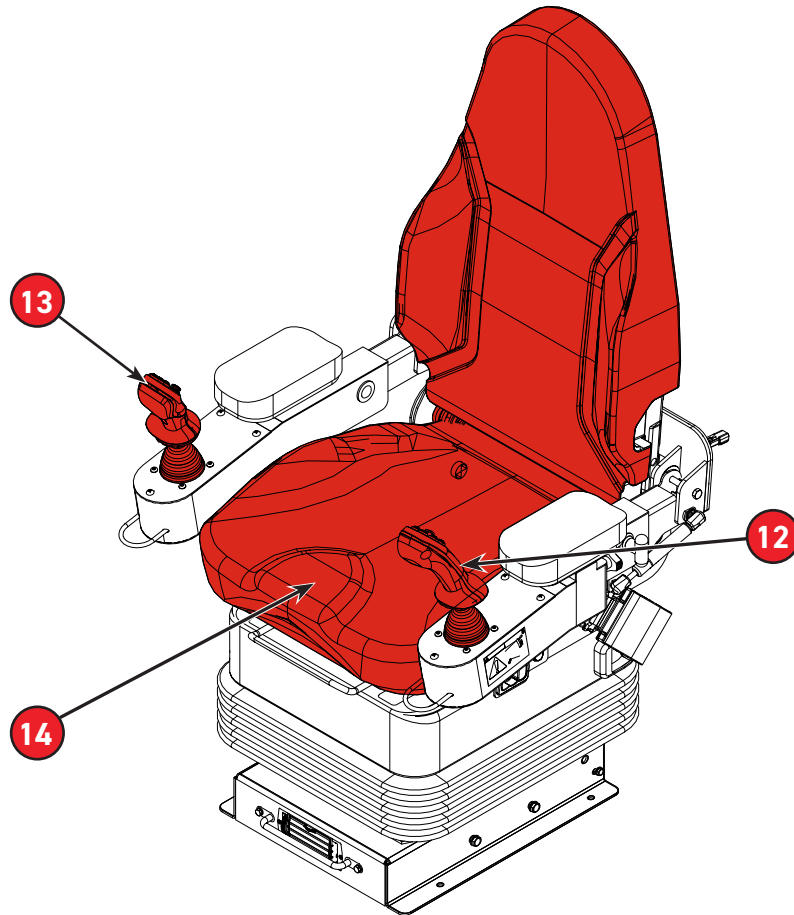

Operator's Seat Controls

## 50-155 M & U

Description of Machine and Controls  
Operator's Seat Controls

### 12. Left Hand (LH) Joystick Control Lever

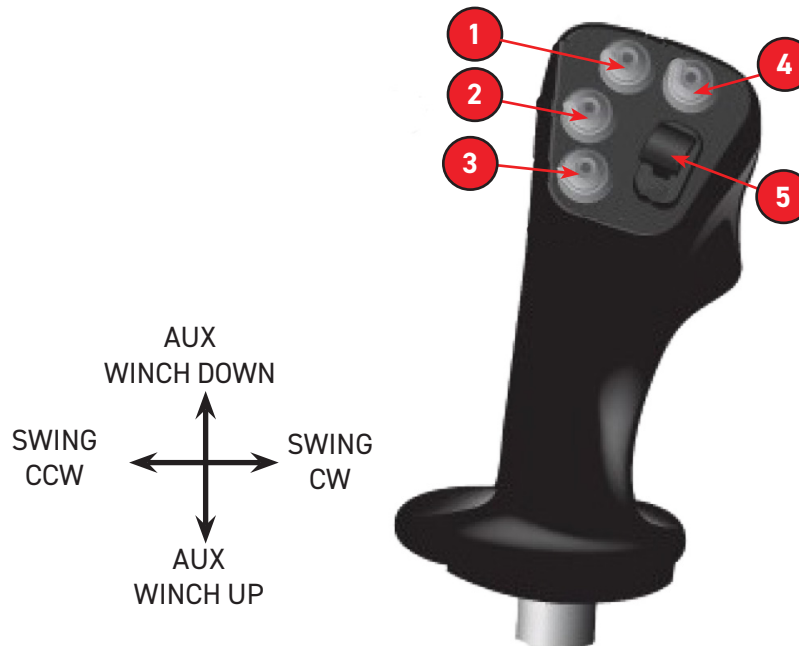

1. Horn
2. Aux Winch HS
3. Aux Winch ON/OFF
4. Tele HS
5. Tele

This joystick incorporates the controls for turret slewing, the release of the superstructure rotation brake, extension/retraction of the telescopic boom, the auxiliary winch, and the two-speed winch.

- The safety switch device is in the left hand armrest (LH). Lowering the armrest will activate both joystick control levers. In order to enable exiting and egress of the cab, the LH armrest must be in the **UP** position to prevent accidental maneuvers.
- **Main Winch - Two-Speed Switch** - Depressing the switch at the top right of the joystick control will shift the winch speed to **HI SPEED** mode and the red LED light in the switch will illuminate. Depressing the switch at the bottom will toggle the switch back to normal **LOW SPEED** mode, and the red LED light will turn off.
- **Winch Disable Switch** - Depressing the switch will engage the winch and a green LED light will illuminate. Depressing the switch a second time will disable the winch and the green LED light will go off.
- **Boom Telescope Switch** - Pushing upward and forward on the rocker switch will extend the boom sections. Pulling downward on the switch will retract the boom sections.

## 50-155 M & U

### Description of Machine and Controls Operator's Seat Controls

#### Operation With Only One Winch

- Push forward on the center rocker switch to extend the boom sections. The speed of the boom extend is proportional to the throttle setting and movement of the switch.
- Pull rearward on the center rocker switch to retract the boom sections. The speed of the boom retract is proportional to the throttle setting and movement of the switch.
- Move the LH joystick control lever to the right to turn the turret clockwise. The swing speed is proportional to the throttle setting and movement of the joystick.
- Move the LH joystick control lever to the left to turn the turret counterclockwise. The swing speed is proportional to the throttle setting and movement of the joystick.

When the joystick control lever is in the middle position, two functions are activated simultaneously (e.g., load and boom lowering).

#### Operation With Auxiliary Winch (Optional)

- Push AUX WINCH ON/OFF to disable the auxiliary winch. A green LED light in the switch will be ON and the main winch function will be disabled.



Disabling the auxiliary winch function when it is not being used prevents damage to the cable on the winch when it is not rigged over the boom head.

- Depress switch to change auxiliary winch speed to HI. A red LED light in the switch will be ON and the auxiliary winch wire rope take in and pay out speed will be set to HI SPEED mode.
- Move the joystick control lever to the right to turn the turret clockwise.
- Move the joystick control lever to the left to turn the turret counterclockwise.
- Pull the joystick control lever back to lift the load with the auxiliary winch.
- Push the joystick control lever forward to lower the load with the auxiliary winch.



Release the main or auxiliary winch rope when extending the boom to prevent the hoisting block head from tripping the stop limit device. Failure of this device could result in serious damage to the boom head or the telescopic extension and the rope. The rope could break, causing the load to drop, resulting in serious damage or fatal accidents.

A thumper indicator is built into the joystick control handle. The thumper indicator is activated when the auxiliary winch joystick control is moved forward or rearward. This activation provides the Operator with tactile force feedback that they can feel through the joystick control.

## 50-155 M & U

Description of Machine and Controls  
Operator's Seat Controls



### Manual Superstructure Rotation Brake Release Switch

Flip the swing brake switch on the right armrest to manually release the friction swing brake and allow self-alignment of the boom end vertically over the center line of the load being lifted.



Do not change the winch speed if the winch joystick is not in the neutral position and the drum is turning.

### 13. Right Hand (RH) Joystick Control Lever

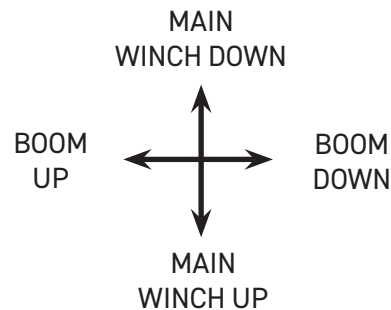
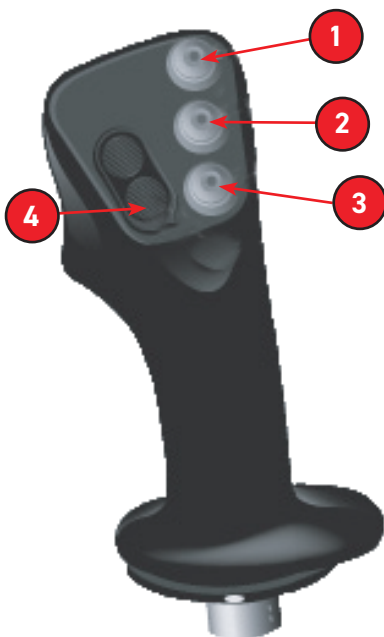

- |                      |
|----------------------|
| 1. Throttle Lock     |
| 2. Main Winch HS     |
| 3. Main Winch ON/OFF |
| 4. Swing Park Brake  |

The right hand (RH) joystick control lever controls load lifting and lowering with the main winch, raising and lowering the telescopic boom, the two-speed winch control, the winch disable switch, and the horn.

- Push WINCH DISABLE switch to disable the main winch. A green LED light on the switch will be **ON** and the main winch function will be disabled.
- Disabling the main winch function when it is not being used prevents damage to the cable on the winch when it is not rigged over the boom head.
- Push the TWO-SPEED WINCH switch to change the main winch speed to **HI**. A red LED light on the switch will turn **ON** and the main winch wire rope take-in and pay-out speed will be set to **HIGH SPEED** mode.

## 50-155 M & U

### Description of Machine and Controls Operator's Seat Controls

- Push joystick control lever forward (MAIN WINCH DOWN) to lower the load with main winch. The winch wire rope speed for lowering the load is proportional to the throttle setting and movement of the joystick.
- Pull back joystick control lever (MAIN WINCH UP) to lift the load with the main winch. The winch wire rope speed for raising the load is proportional to the throttle setting and movement of the joystick.
- Move the joystick control lever to the left (BOOM UP) to raise the boom. The boom raising speed is proportional to the throttle setting and movement of the joystick.
- Move the joystick control lever to the right (BOOM DOWN) to lower the boom. The boom lowering speed is proportional to the throttle setting and movement of the joystick.

When the joystick control lever is in the middle position, the two functions are activated simultaneously (e.g., load and boom lowering).

A thumper indicator is built into the joystick control lever. The thumper indicator is activated when the main winch joystick control is moved forward or rearward. This activation provides the Operator with tactile force feedback that they can feel through the joystick control.



Do not combine opposite functions. (Example: retracting one outrigger beam while simultaneously extending another, or lowering one vertical cylinder while simultaneously raising another).



Be sure the machine is perfectly stabilized before handling loads. Check the spirit level in the Greer TS7 (LMI) display on a regular basis to ensure that the leveling adjustment is correct.

14. **Seat Controls** - Refer to the section "[Operator's Seat Controls](#)".

15. **Roof Hatch Lock Handle** - Retain control of both raise/lower handles when unlatching (15) until hatch is fully open. Pull down on both handles when closing hatch and rotating (15) lock handles. Keep head clear when pulling the hatch down.

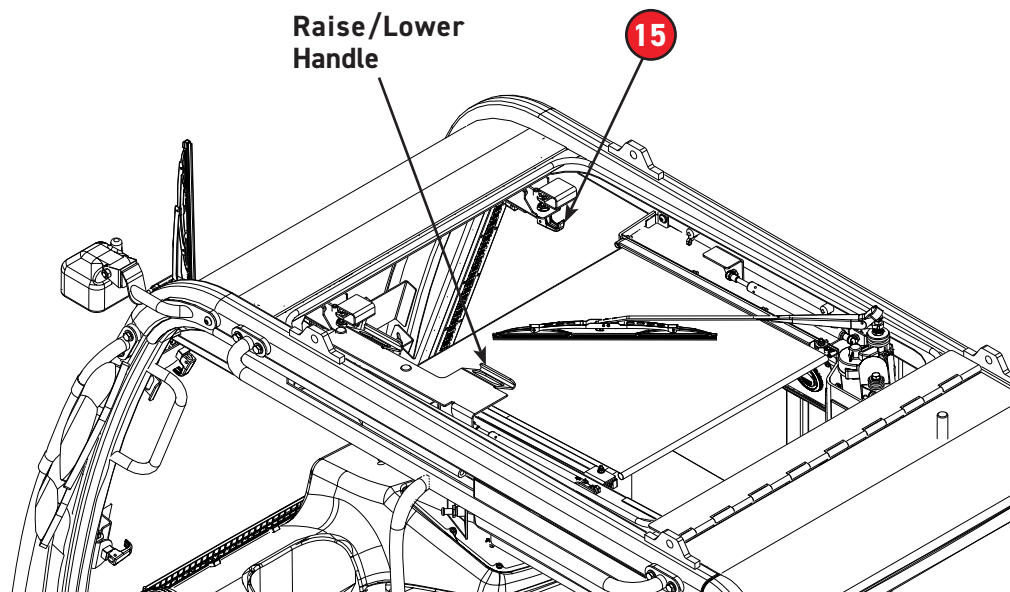

# 50-155 M & U

Description of Machine and Controls  
Operator's Seat Controls

## 16. Windscreen Lock

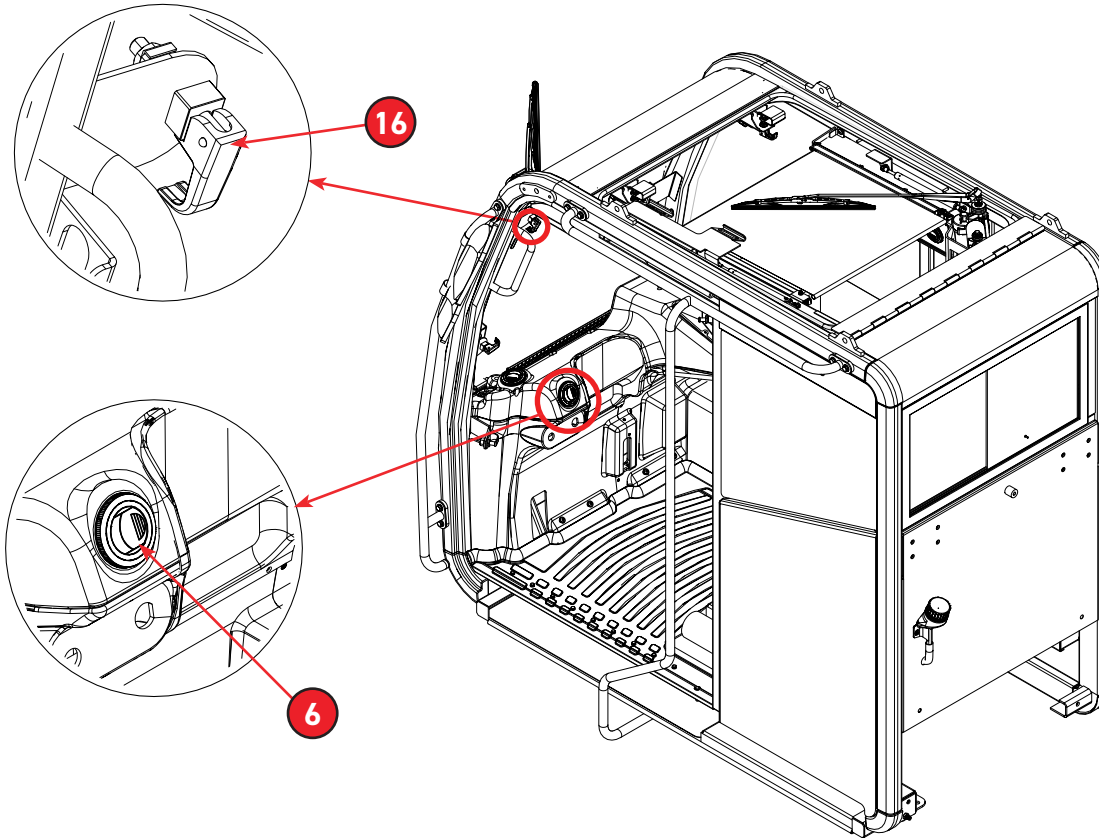

Windscreen Lock and HVAC Vent

## 50-155 M & U

### Description of Machine and Controls Operator's Seat Controls

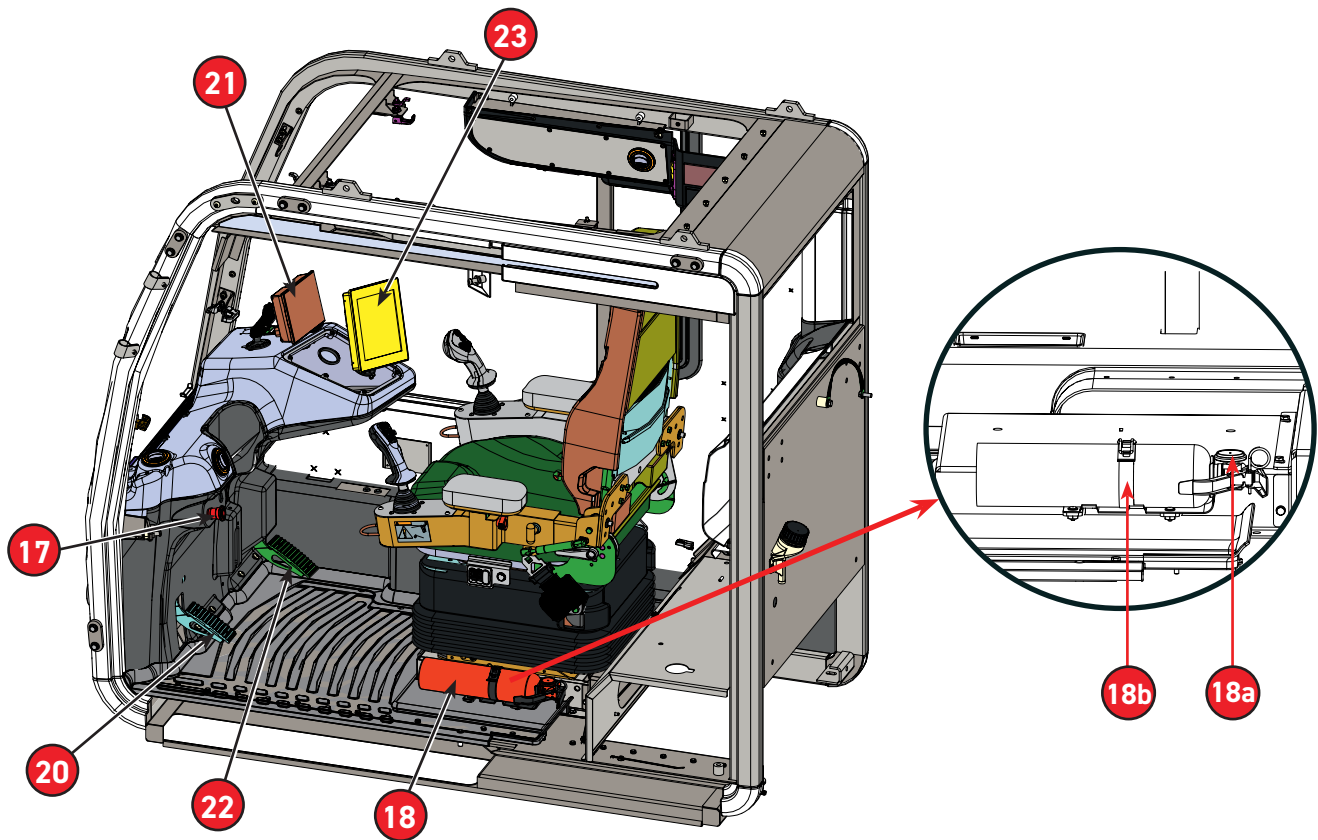

**Cab Interior Controls**

17. **Emergency Stop Button** - In case of emergency, push the red emergency stop button to the off position to stop all crane functions, including engine operation. Rotate the red emergency stop button clockwise and pull the button out to enable normal operation of the crane.
18. **Fire Extinguisher** - The fire extinguisher is mounted inside the Operator's cab, next to the seat's base. The Operator can access the extinguisher while seated inside the cab. It can be accessed from outside the cab by opening the Operator's cab door.
  - 18a. **Gauge** - Check the gauge daily to verify that the charge-level needle is in the green zone.
  - 18b. **Release Latch** - Lift this latch to release the extinguisher from the mounting bracket.

## 50-155 M & U

Description of Machine and Controls  
Operator's Seat Controls

### 19. Roof Sunshade

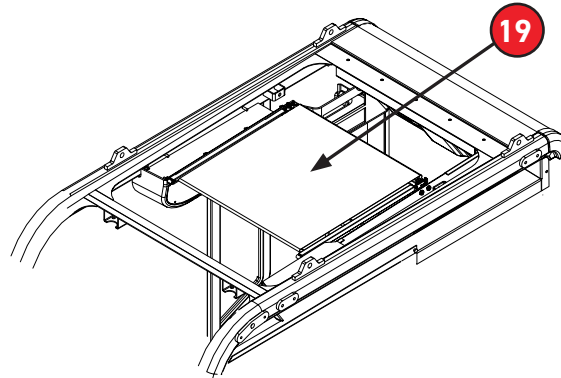

**Roof Sunshade**

- 20. **Swing Brake Pedal** - Apply swing brake with the foot pedal.
- 21. **Engine Display Monitor**
- 22. **Accelerator Pedal** - Depress to increase the engine's RPMs.
- 23. **GS Control Screen** - Refer to Description of Machine and Controls, "[Control Screens](#)".

## 50-155 M & U

Description of Machine and Controls  
Upper Controls and Instruments

### Upper Controls and Instruments

#### Operator's Seat Controls

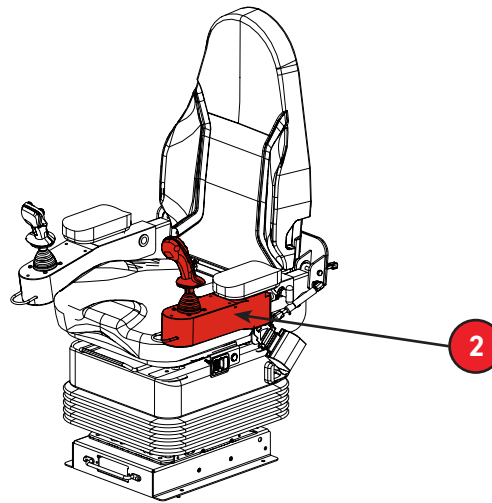
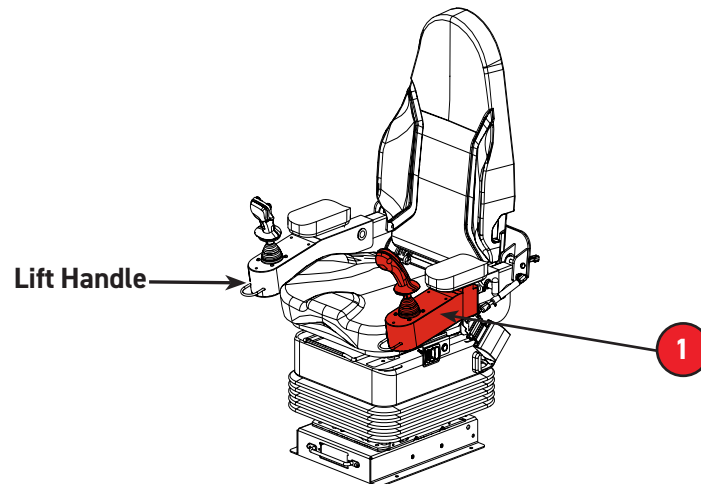

1. **Seat Control Arm (Down Position)** - When the arm is in the DOWN (horizontal) position with the engine running, the joystick control is live. When entering or exiting the cab, use the lift handle on the arm to rotate the arm to the UP position.



Do not enter or exit the cab with the arm in the DOWN (horizontal) position.

2. **Seat Control Arm (Up Position)** - When the arm is in the UP (vertical) position and the engine is running, the joystick control is OFF. The arm must be in this position to enter or exit the cab. Use the lift handle on the arm to lower the arm into position once the Operator is seated.

## 50-155 M & U

Description of Machine and Controls  
Upper Controls and Instruments

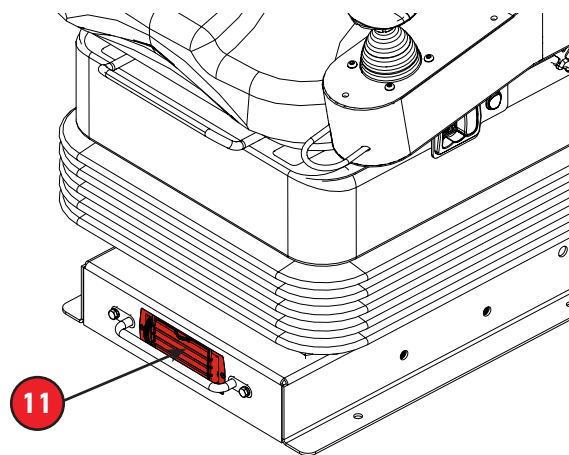
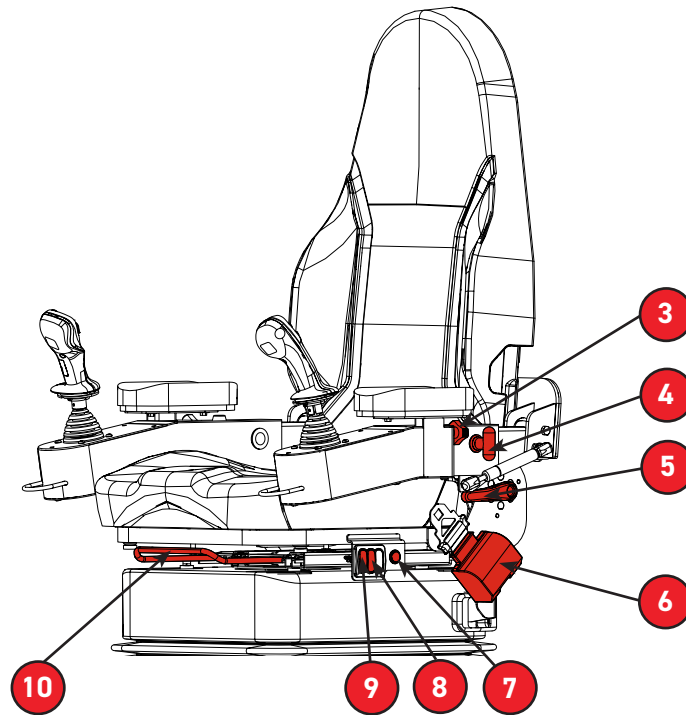

3. **Armrest Adjustment Knob** - Loosen knob to adjust the armrest up/down to the Operator's preference. Tighten the knob to secure the armrest in position.
4. **Armrest Fore/Aft Adjustment Knob** - Loosen the knob and the armrest will slide forward or rearward, allowing the Operator to comfortably position the joystick control lever. Tighten the knob to secure the armrest in position.
5. **Backrest Angle Control Lever** - Lift the lever to release the backrest angle locking mechanism, then adjust the backrest to the Operator's preference and release the lever. The seat backrest can be folded completely forward onto the seat base for access to the heater or windshield washer bottle behind seat.

## 50-155 M & U

### Description of Machine and Controls

#### Upper Controls and Instruments

6. **Retractable Seat Belt** - Before operating the crane, attach the seat belt. Raising the right-hand arm to the UP position will allow easier access for latching/unlatching the seat belt. Press the red button on the seat belt to unlatch and exit the seat and cab.
7. **Heated Seat Control Switch** - The rocker switch controls the seat's heat. For low heat, the rocker switch should be in the ON position and displaying a green LED light. For high heat, the rocker switch should be in the ON position and displaying a red LED light. To turn the seat's heat off, ensure that the rocker is in the OFF position and that no light is visible. Ensure that the rocker switch is in the OFF position when the engine is not running in order to prevent the battery from being drained.
8. **Lumbar Switch** - Press the top portion of the rocker switch to inflate the seat backrest lumbar support.
9. **Height Adjustment** - Press the top portion of the rocker switch to raise the seat base height. Keep weight off the seat base until the desired height is achieved, as the air system cannot raise the Operator. To lower the seat base height, press the lower portion of the rocker switch while remaining seated.
10. **Seat Fore/Aft Slide Bar** - Lift the bar and push the seat forward or backward to adjust the seat position in relation to the foot controls. Release the bar when the desired position is achieved.
11. **Heat Adjustment Louver** - The heat output to the Operator's feet can be controlled by adjusting the wheel on the louver.

# 50-155 M & U

Description of Machine and Controls  
Control Screens



## Control Screens

This section is intended to familiarize the Operator with the control screens provided for the operation of this machine.



Home Page Screen

1. Cab Controls	7. Diagnostics
2. Outrigger Controls	8. Lifting Screen
3. Manuals	9. Engine Information
4. Unit Information	10. Fuse Box
5. Joystick Controls	11. Hydraulic Information
6. Tools Menu	12. Operator Select



For more information, refer to the GS manual provided with your unit.

# 50-155 M & U

## Description of Machine and Controls Control Screens

### 1. Cab Controls



**Cab Control Screen**

1. Power	10. Cab Lights
2. Heat	11. Roof Wiper Speed Decrease
3. Defrost	12. Roof Wiper Speed Increase
4. Air Conditioning	13. Roof Washer
5. Fan Speed Decrease	14. Lights
6. Fan Speed Increase	15. Lights
7. Temperature Decrease	16. Front Wiper Speed Decrease
8. Temperature Increase	17. Front Wiper Speed Increase
9. Beacon Light	18. Front Washer

# 50-155 M & U

Description of Machine and Controls  
Control Screens



## 2. Outrigger Controls

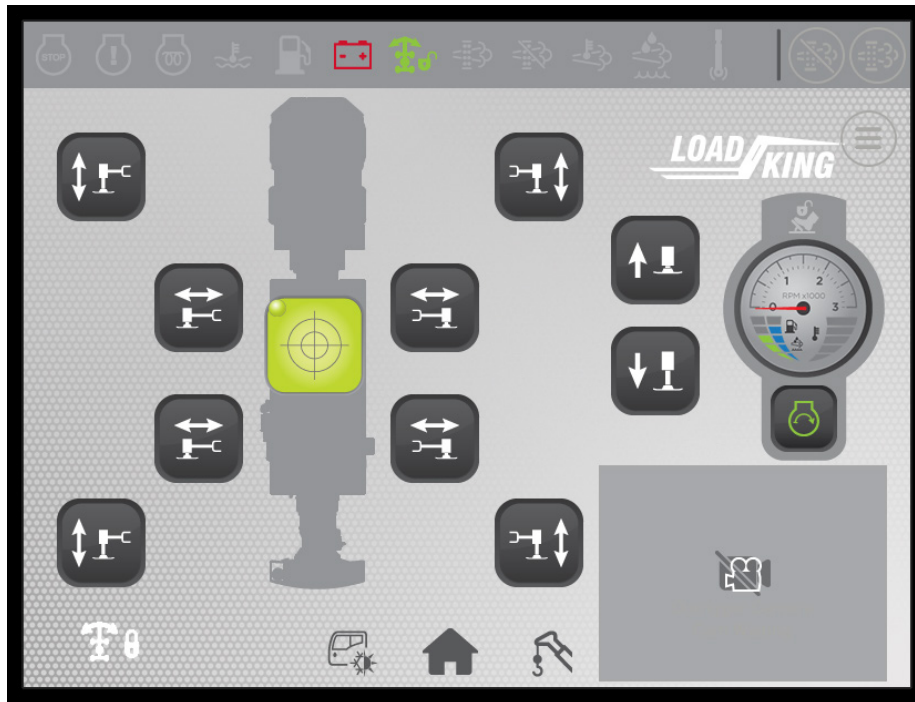

Outrigger Control Screen

## 3. Manuals



Manual Screen

# 50-155 M & U

## Description of Machine and Controls Control Screens

### 4. Unit Information

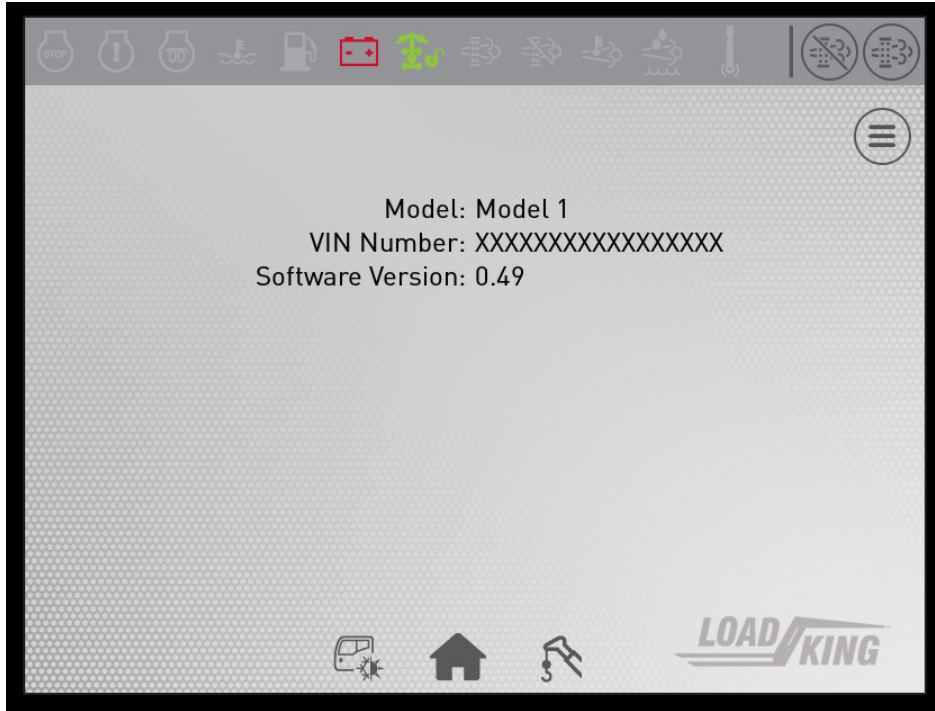

Unit Information Screen

### 5. Joystick Controls

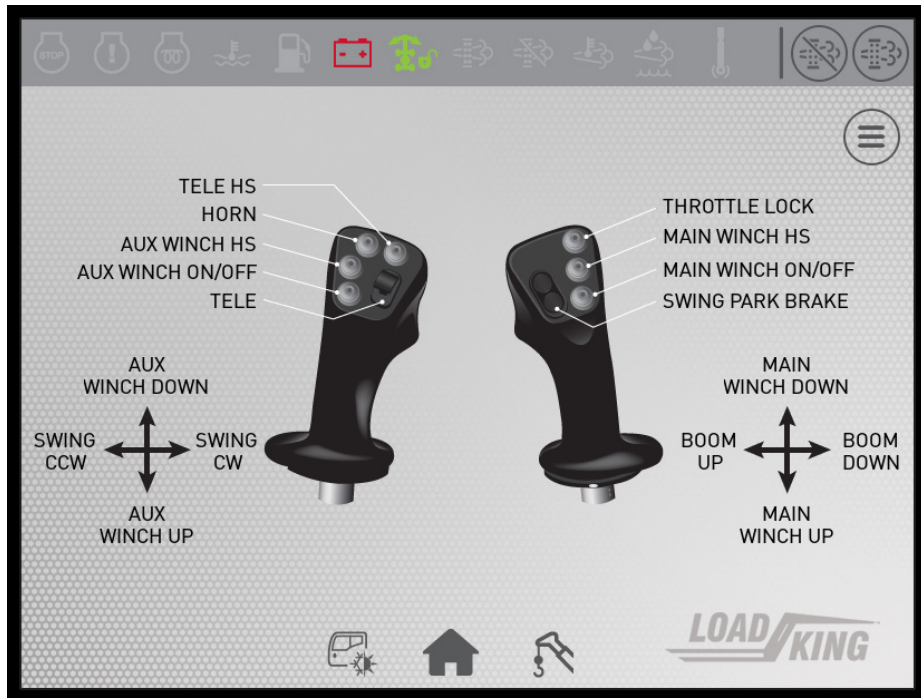

Joystick Control Screen

# 50-155 M & U

Description of Machine and Controls  
Control Screens

## 6. Tools Menu

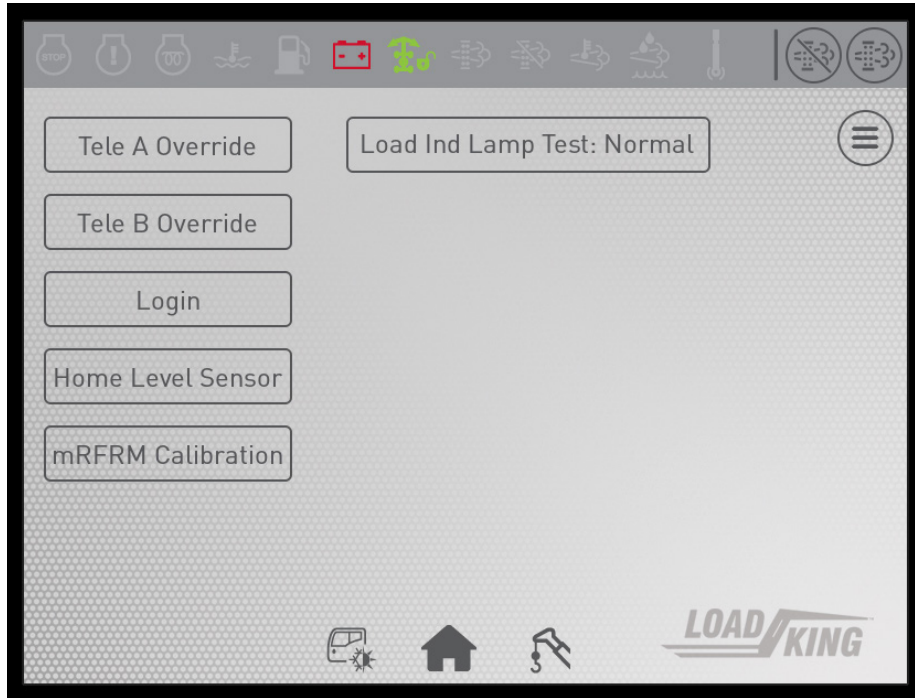

Tools Menu Screen

## 7. Diagnostics

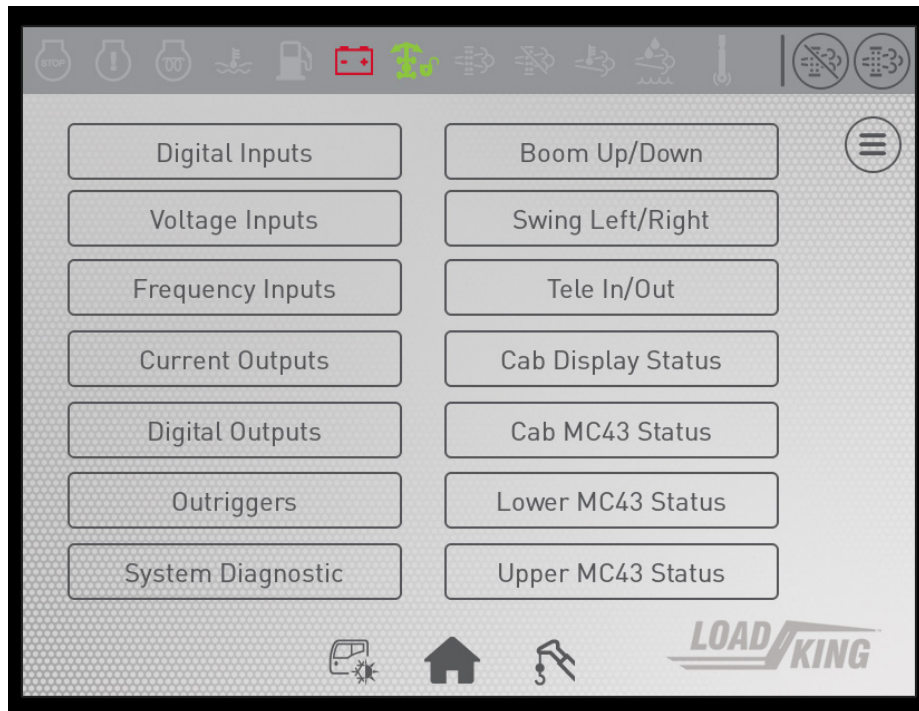

Diagnostics Control Screen

## 50-155 M & U

### Description of Machine and Controls Control Screens

#### 8. Lifting Screen



**Lifting Control Screen**

1.	Cab Tilt Raise
2.	Cab Tilt Lower
3.	Jib Stow Assist Extend
4.	House Lock Engage/Disengage
5.	Remote Control Enable
6.	Jib Stow Assist Retract

# 50-155 M & U

Description of Machine and Controls  
Control Screens



## 9. Engine Information

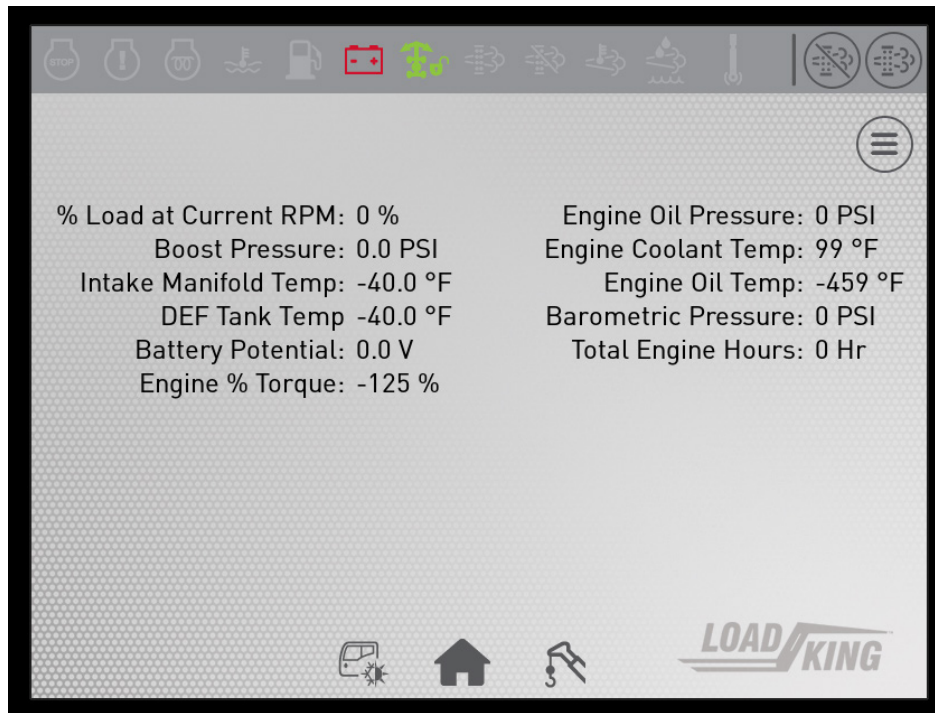

Engine Information Screen

## 10. Fuse Box

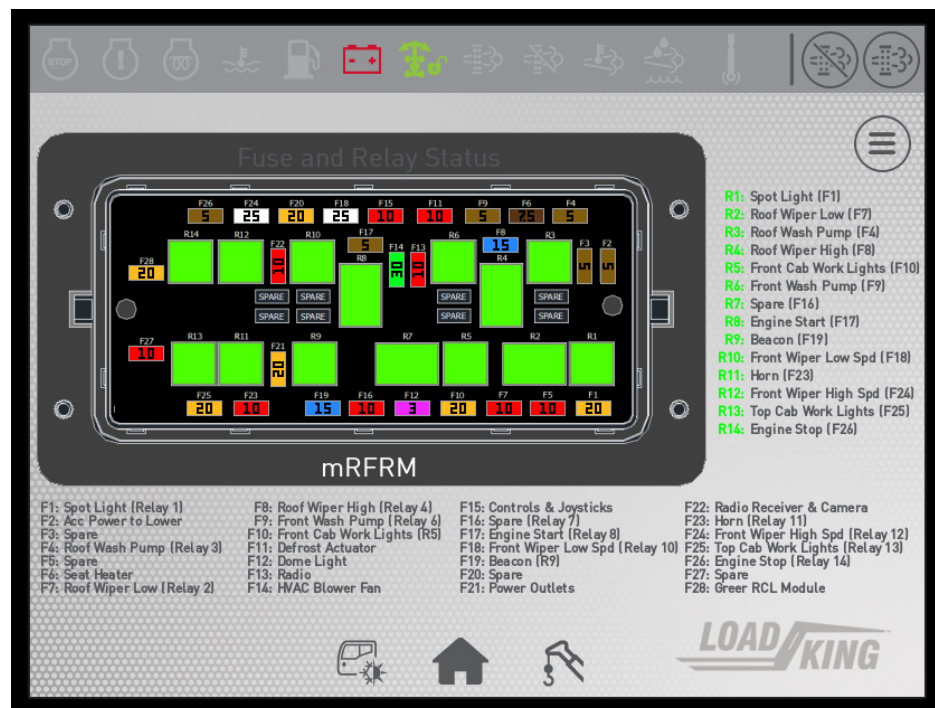

Fuse Box Screen

# 50-155 M & U

## Description of Machine and Controls Control Screens

### 11. Hydraulic Information

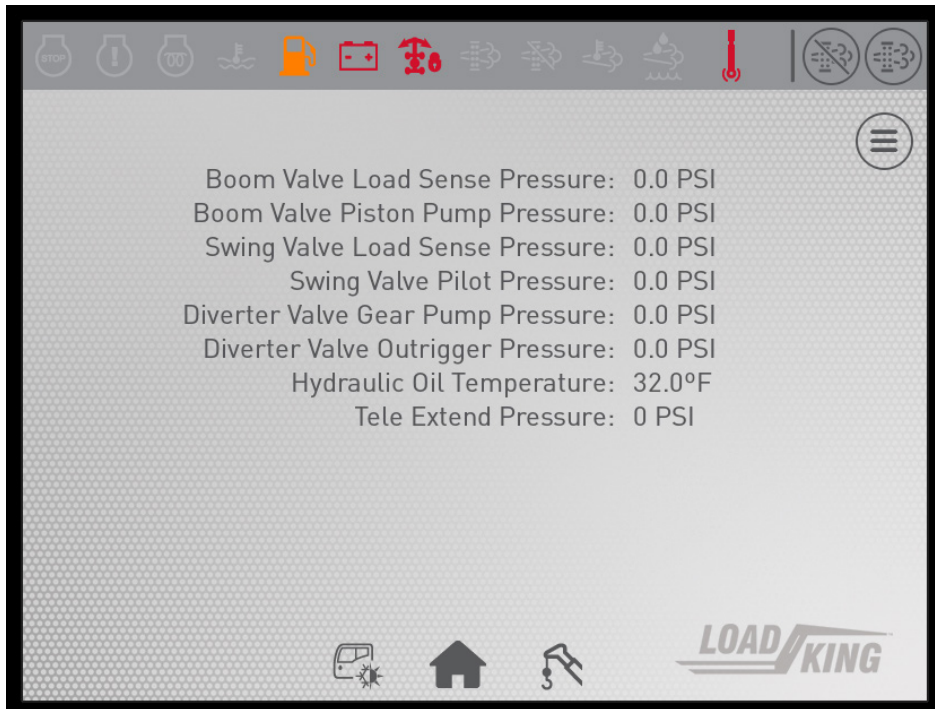

Hydraulic Information Screen

### 12. Operator Select

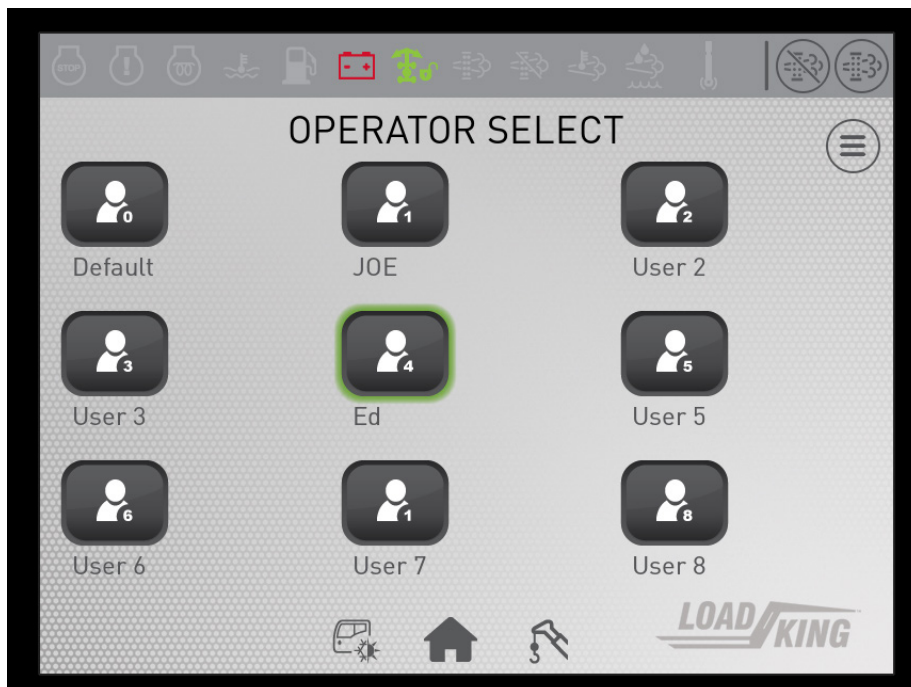

Operator Select Screen

## 50-155 M & U

Description of Machine and Controls  
Power Take-Off (PTO)

### Power Take-Off (PTO)



Disengage the power take-off (PTO) before driving truck. Failure to do so will cause damage to the transmission and hydraulic pump.

#### Transmission Mounted, Electric Clutch Shift PTOs

##### Allison Transmission/Eaton Fuller Manual Transmission

To engage PTO:

1. Set parking brake.
2. Shift transmission to neutral (N).
3. Engage PTO with the rocker switch on the dashboard (1).

To disengage PTO:

1. Store boom in boom rack.
2. Store outriggers.
3. Disengage PTO with the rocker switch on the dashboard (1).
4. Shift transmission into gear (if necessary).
5. Release parking brake (if necessary).

Item 1 shows an example of, but is not limited to, PTO switches as located on the dash of the truck cab.



1

1. PTO Engage Switch

# 50-155 M & U

Description of Machine and Controls  
Carrier Controls and Instruments

## Carrier Controls and Instruments

### Outrigger Control Box-Carrier Frame



When deploying outriggers, raise all jacks evenly. Extending rear jacks without extending front jacks can cause damage to the crane's frame structure.

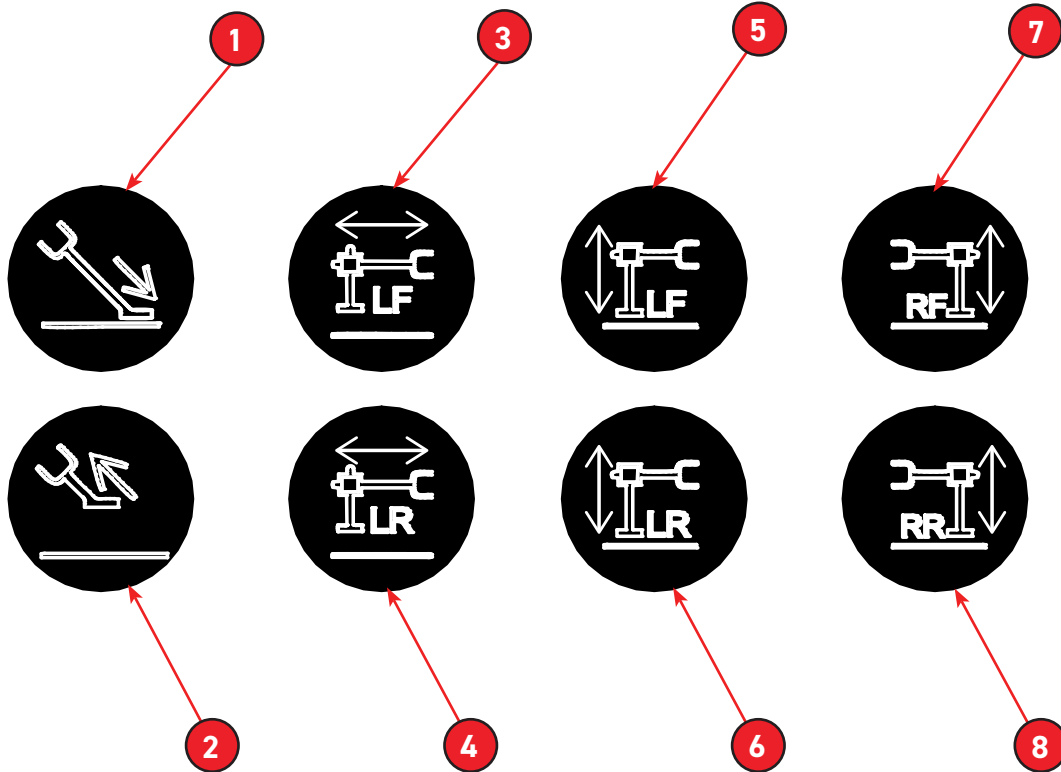

<p>1. <b>Extend Switch:</b> This switch is used to extend the outrigger. When activated, the backlight is green.</p>	<p>5. <b>Front Left Jack Switch:</b> This switch is used to extend/retract the jack.</p>
<p>2. <b>Retract Switch:</b> This switch is used to retract the outrigger. When activated, the backlight is blue.</p>	<p>6. <b>Rear Left Jack Switch:</b> This switch is used to extend/retract the jack.</p>
<p>3. <b>Front Beam Swing Out/In Switch:</b> This switch is used to swing out/in the beam.</p>	<p>7. <b>Front Right Jack Switch:</b> This switch is used to extend/retract the jack.</p>
<p>4. <b>Rear Beam Swing Out/In Switch:</b> This switch is used to swing out/in the beam.</p>	<p>8. <b>Rear Right Jack Switch:</b> This switch is used to extend/retract the jack.</p>



Outrigger control box is located on both driver and passenger sides of vehicle.

## 50-155 M & U

Description of Machine and Controls  
Outrigger Controls Screen

### Outrigger Controls Screen



Outrigger Controls Screen

1. Front Left Jack	6. Front Right Beam Swing Out/In
2. Front Left Beam Swing Out/In	7. Rear Right Beam Swing Out/In
3. Rear Left Beam Swing Out/In	8. Rear Right Jack
4. Rear Left Jack	9. Retract Function
5. Front Right Jack	10. Extend Function

To operate the outriggers, select the desired function from items 1-8, then use item 9 or 10 to extend or retract the selected function.

## 50-155 M & U

Description of Machine and Controls  
Side-Stow Jib

### Side-Stow Jib

Optional jib extensions are available to provide additional boom reach.

The jib is a 30-58 ft. (9.1m - 17.67m) side-stow swing-on. It is a bi-fold with a lattice section and a tubular stinger section. Total weight is 2,400 lbs. (1089 kg).

The optional jib extension is pinned directly to the ends of the sheave pins. When not in use, the jib can be unpinned from the boom head and stored on the mounting brackets on the right side of the boom base section.

Refer to "[Jib Deployment and Stowage](#)" section for the respective procedures for the usage of the jib.

#### Jib Swing Path - Deployment and Stowage

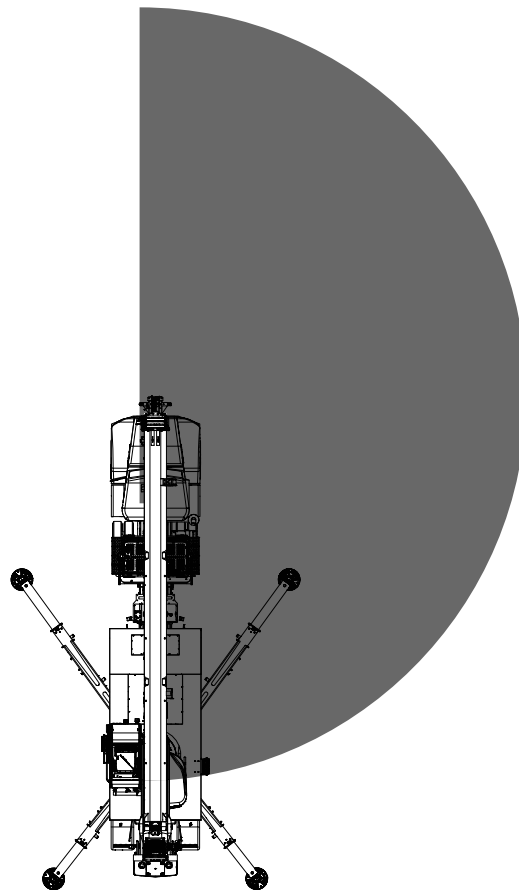

Before stowing the jib, ensure that no personnel or obstacles are in the swing path of the jib.

## 50-155 M & U

Description of Machine and Controls  
Load Moment Indicator and Anti-Two-Block



### Load Moment Indicator and Anti-Two-Block

#### Load Moment Indicator System

The **Load King** Boom Truck is equipped with the Greer Insight Load Moment Indicator System. The Operator is provided with a continuous readout of load movement indicator, approach to overload, and two-block condition. Refer to Appendix section "[Greer LMI Operator's Manual](#)" for proper maintenance and setup of unit.

#### Anti-Two-Block Components

##### Cable Reel

The Anti-Two-Block (ATB) cable is wound onto a spring-loaded cable reel which is bolted to the left side of the boom base. The reel allows the cable to pay-out and take-in as the length of the boom is changed. The cable reel has slip rings which allow electric current to flow even while the reel is turning. This cable and reel assembly is also used to measure boom extension when the Boom Truck is fitted with an LMI system.

##### Limit Switch

An ATB switch is mounted on the left side of the boom tip. The switch is normally open. During operation, the switch is held closed by a counterweight suspended from the switch lever by a chain. The closed limit switch allows current to close the relay in the junction box in the mainframe. When the load block (or down haul weight) is lifted too high, it will lift the counterweight. This action will cause the limit switch to open, breaking the circuit to the relay. This in turn, de-energizes the coil on the unloader block assembly.

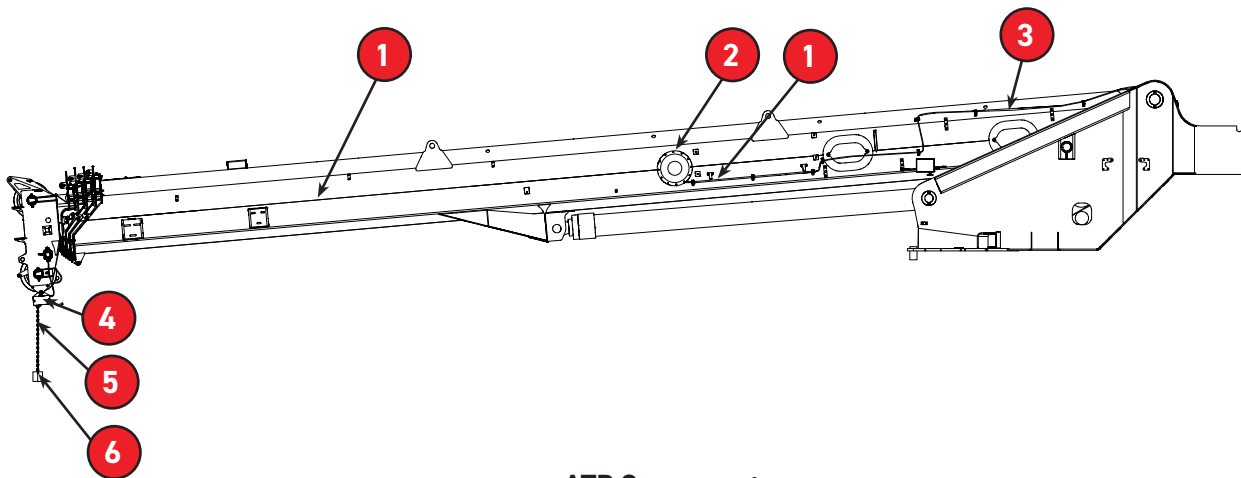

ATB Components

1. ATB Wire	4. ATB Switch
2. ATB Reel	5. ATB Chain
3. ATB (to Collector Ring)	6. ATB Weight



The Greer TS7 (LMI) is designed as an aid. Refer to "[Maximum Load and Boom Angle Charts](#)" for proper operating zones.

**PAGE INTENTIONALLY LEFT BLANK**

## Operating Instructions

### Job Site

#### Job Site Setup Procedure

1. Position the vehicle on solid, level ground. Fully engage the parking brake and place the transmission in neutral.
2. Activate the crane's master power. Refer to the [Power Take-Off](#) section of the Operator's Manual for PTO engagement due to the differences in activation, transmission types, and PTO locations.
3. Engage the PTO. When the pump PTO is engaged, it allows the hydraulic oil to warm up to prevent pump damage. Never drive a vehicle with the pump PTO engaged.
4. Check the hydraulic system filter indicator to confirm that the filter is functioning properly.
5. Extend all outriggers to firm contact with solid, level surface and level the vehicle. Raise the crane enough to lift the tires off the ground.
6. Always pay out winch line before extending the boom.



Maintain an appropriate winch payout. Failure to do so will result in the load block contacting the Anti-Two-Block (ATB) switch, which will shut down the boom extend function or damage the crane.

7. Always know the operating radius (the distance from the centerline of rotation to the load hook), and the actual weight of load being lifted. The load radius may vary at different rotation positions.
8. If the boom will be operated beyond the boundary of the main outriggers the least stable boom position is over the side of the crane. Refer to the crane's load charts to ensure that the maximum lifting capacity of the crane is not exceeded.

## 50-155 M & U

### Operating Instructions Outrigger Position

## Outrigger Position

Before conducting any boom operation, the Operator must extend all outriggers on a firm and level surface. Other conditions may exist, such as but not limited to: loose or sandy soil; Crusty or frosty surfaces with soft soil underneath; icy or slick pavement; sloping surfaces; the Operator will be required to restrict operations. In some areas, the Operator may be able to level the crane with the use of pads or blocks (cribbing). These pads must be of adequate material to support the outrigger without collapsing and should not exceed two (2) inches in thickness. If the main outriggers cannot be placed at or near the same level as the wheels, the outrigger spread will be affected. This can result in damage to the crane and/or instability.

### Outrigger Positions - For Load Handling 360 Degrees, Over Side, Rear or Front of Unit

The outrigger spread has three (3) positions related to the Load Rating Chart Interpretation section of this manual.

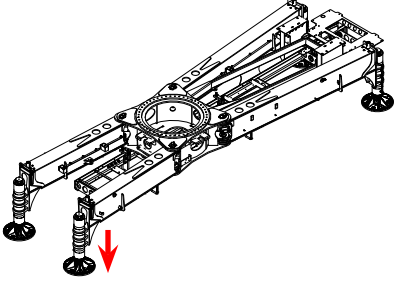
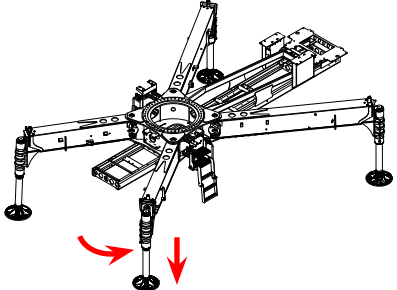
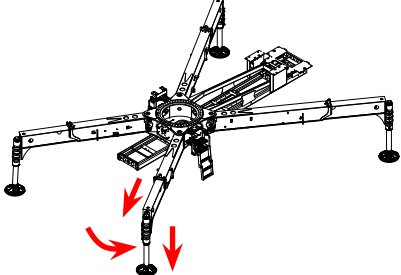
Outrigger Positions	
<p><b>Position 1</b></p> <ul style="list-style-type: none"><li>• The beam swing-out cylinders are fully <b>RETRACTED</b>.</li><li>• The inner beam's extend cylinders are fully <b>RETRACTED</b>.</li><li>• The jack cylinders are <b>EXTENDED</b>.</li><li>• The outrigger pads are on the ground and the tires are off the ground. The crane is leveled by adjusting the length of each jack's cylinder.</li></ul>	
<p><b>Position 2</b></p> <ul style="list-style-type: none"><li>• The beam swing-out cylinders are fully <b>EXTENDED</b>.</li><li>• The inner beam's extend cylinders are fully <b>RETRACTED</b>.</li><li>• The jack's cylinders are <b>EXTENDED</b>.</li><li>• The outrigger pads are on the ground and the tires are off the ground. The crane is leveled by adjusting the length of each jack's cylinder.</li></ul>	
<p><b>Position 3</b></p> <ul style="list-style-type: none"><li>• The beam swing-out cylinders are fully <b>EXTENDED</b>.</li><li>• The inner beam's extend cylinders are fully <b>EXTENDED</b>.</li><li>• The jack cylinders are <b>EXTENDED</b>.</li><li>• The outrigger pads are on the ground and the tires are off the ground. The crane is leveled by adjusting the length of each jack's cylinder.</li></ul>	

## 50-155 M & U

Operating Instructions  
Work Site Position



The front tires should remain close to the ground (2-5 in.) when the unit is set up and leveled.

Each outrigger contains proximity sensors. These sensors prevent the inner beam from being extended while the crane is in Position 1; such extension would cause damage to the crane's chassis. The proximity sensors also prevent the outrigger inner beams from being extended until the swing-out beams are fully extended, as in **Position 3**.

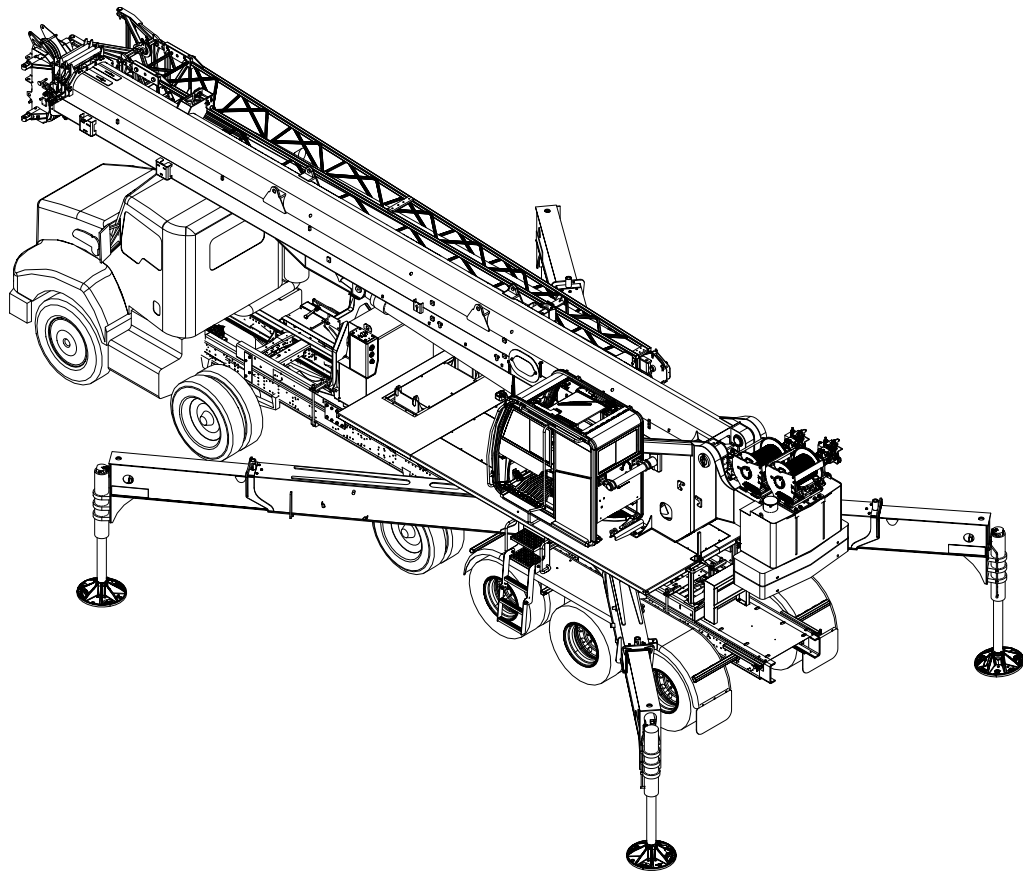

Observe caution notes on outrigger movement whenever setting up or stowing outriggers.

### Work Site Position

The best possible work site should always be sought when the Operator is positioning the crane. An ideal location is where the ground is firm, level, and dry. The crane should be situated in close proximity to the work area. The site should be free of overhead obstructions. Maintain safe clearances from electrical power lines and apparatus. The Operator must allow for boom and platform sway, rock, or sag, and electrical line and load line swaying.

## 50-155 M & U

Operating Instructions  
Cold Weather Operation

### Cold Weather Operation

While operating in cold weather temperatures 32° F (0° C) or below, the Operator must allow the hydraulic oil to warm up to operating temperature as indicated through the control panel interface. This can be accomplished by allowing the hydraulic pump to run under no load for ten minutes at low engine speed. Further, actuate all the controls slowly until controls move smoothly and easily. In extreme cold conditions (temperatures -40°F (-40°C) or below), extra care must be taken to avoid any impact loading. Materials which are normally ductile can become brittle at extreme cold temperatures.

An optional Cold Weather Package is available for this crane. Information about the operation of this equipment in cold weather conditions and components included in the Cold Weather Package, refer to sections [Cold Weather Recommendations](#) and [Cold Weather Package Specifications](#).



Failure to allow the hydraulic oil to warm up may cause damage to the pump and delay the response time of function controls.

## General Operational Issues

### Ignition Switch-Carrier Cab and Upper Operator's Cab

When moving from the carrier cab to the upper cab, the carrier cab ignition switch must be in the ON position for the upper crane cab to function and start or stop the engine.

### Best Practices

1. Always operate controls to lower the load line while extending the boom. This will maintain clearance between the boom tip and the down haul weight.
2. Ensure that the load line is not twisted or kinked, and that the load line is properly seated on the drum and in sheaves.
3. When raising or lowering the winch, meter all controls and apply power smoothly; do not make sudden starts or stops.
4. When hoisting a load, raise it a few inches and allow the controls to return to neutral to determine if the winch brake and boom holding valves are working properly.
5. Do not make side pulls with the boom. This type of loading can damage the boom and the rotation mechanism. Do not raise or lower a load in such a manner that would cause side loading.



Observe caution notes on outrigger movement whenever setting up or stowing outriggers.

6. When lifting a load, make sure that three (3) full wraps of rope remain on the winch drum at all times. Maintain tension on the load line at all times to prevent the rope from becoming twisted or kinked, and to keep the cable properly seated on the drum and sheaves. When lifting loads that exceed the single part line limitation shown on your maximum load chart, refer to the chart's instructions on how to multipart the load line.



When using a multi-part load line, boom extension must be limited to maintain three (3) full wraps on the winch drum.

7. It is imperative to ensure the proper maintenance of the wire rope load line on the **Load King** Boom Truck. Refer to standard ANSI/ASME B30.5 for wire rope inspection and maintenance procedures as well as special provisions for handling maximum rated loads with rotation-resistant ropes. A rope inspection record is provided in the maintenance manual.

## 50-155 M & U

### Operating Instructions

### General Operational Issues

8. Both the load line loop and the drum wedge must be properly seated inside the winch drum before winding the load line on to the winch drum. Refer to the [Maintenance and Service](#) section.

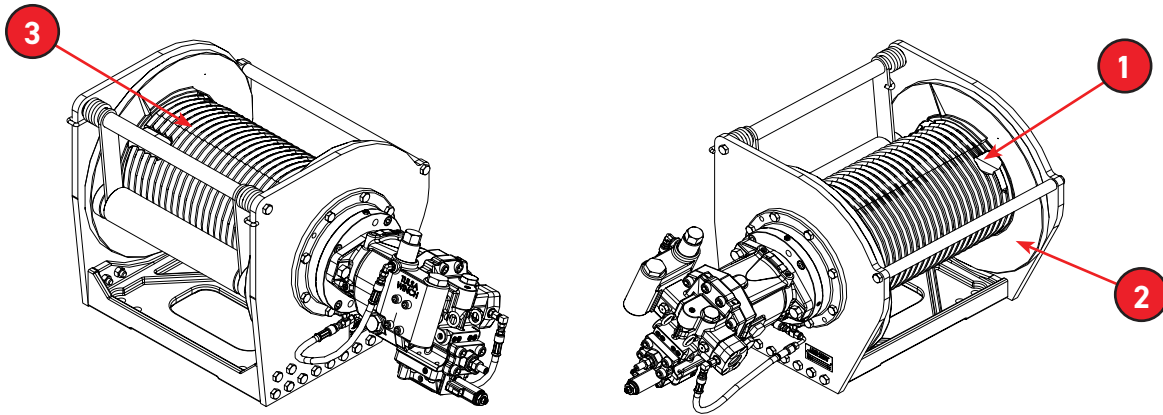

- |                        |
|------------------------|
| 1. Load Line           |
| 2. Drum Wedge          |
| 3. Three Wraps Minimum |

## 50-155 M & U

Operating Instructions  
Safety Devices



### Safety Devices

The safety devices on the **Load King** Boom Truck are described below. These devices help to maintain control of a load in case of power or hydraulic line failure. It is important to understand the function and operation of these devices so that a continual check on their performance can be made.



Stop all operations and contact your authorized **Load King** dealer if any of these devices fail to function.

#### Boom Lift Cylinder Holding Valve

A single-acting holding valve is cartridge-mounted in the cylinder base. This valve holds the boom in extended or elevated positions. If the crane experiences a power failure, a hydraulic pressure line failure, or the boom fails to hold its position ("creeps down"), **STOP ALL OPERATIONS IMMEDIATELY** and contact your authorized **Load King** dealer.



Under no circumstances should the cartridge be removed or attempted to be removed from the lift cylinder base unless an authorized maintenance person is present and the boom is properly supported. If not properly supported, a boom could fall, resulting in property damage, serious injury, or death.

#### Extension Cylinder Holding Valves

The boom extend cylinder has a hold valve that maintains the cylinder's position. If the crane experiences a power failure, a hydraulic pressure line failure, or the boom fails to hold its position ("creeps in"), **STOP ALL OPERATIONS IMMEDIATELY** and contact your authorized **Load King** dealer.

#### Outrigger Cylinder Holding Valve

All outriggers are equipped with internal cartridge-type lock valves. If outriggers fail to hold their position ("creep up") under load, or fail to remain retracted ("creep down") while the vehicle is in motion, consult your authorized **Load King** dealer.

#### Winch Safety Brake

To verify that the brake is functioning, set the outriggers, raise a load a few feet, and release the control handle. Turn off the truck engine and pull the winch control handle down. If the load does not maintain its position ("creeps down"), consult your authorized **Load King** dealer.

#### Swing Drive Brake (Rotation Gearbox)

The rotation gear drive has a spring-applied hydraulic release brake. To verify that the brake is functioning, set the outriggers, swing the boom, and release the control handle. If the boom continues to swing, consult your authorized **Load King** dealer.

## **50-155 M & U**

Operating Instructions

Training and Operator Qualifications

---

### **Training and Operator Qualifications**

It is extremely important that the Operator has a thorough knowledge of all the operating characteristics of the crane. Crane operation shall be limited to personnel with the following minimum qualifications:

- Designated, competent, and experienced persons. If required, a valid certification for operation must be on file.
- Trainees or untrained persons under direct supervision of qualified persons.
- Maintenance and test personnel, only if it is necessary for the performance of their duties.
- Supervisors in the presence of a designated experienced person.

#### **Operator's and trainees will meet the following qualifications:**

- An Operator shall be unhindered by drugs or alcohol, and physically capable of operating the unit.
- Demonstrate ability to read and comprehend all placards, decals, Operator's manuals, codes, and other information pertinent to correct and safe crane operation.
- An Operator shall demonstrate the ability to operate the specific type of equipment or provide satisfactory evidence of qualifications and experience to do so.
- The Operator shall be responsible for all maintenance requirements of the crane that they operate, as well as trainees under the Operator's supervision.
- If an Operator becomes physically or mentally impaired, they shall disqualify themselves.

## Operator Aids

### Anti-Two-Block

The ATB system will sense the presence of the load block in close proximity to the boom tip. The system then automatically interrupts any boom operations which could bring the load block into contact with the boom tip. A warning horn will sound to alert the Operator to the two-block condition.

Those boom functions that could be used to move the load block away from the boom tip will continue to function.

Do not rely on the ATB device as a winch hoist stop.

### Outrigger Warning Alarm

The outrigger warning alarm will sound an audible signal whenever any outrigger swing beam is moving.



The load-indicating equipment on this crane is only intended to aid in safe operation. Do not rely on electronic load/radius indicators to replace the use of capacity charts and proper operating procedures.

### Load Moment Indicator (Greer TS7 Display)

Load Moment Indicator (LMI) system is designed to provide the Operator with information on the load they are lifting and also helps prevent overloading of the crane. In order for this system to be effective, the Operator must read and understand the instructions contained in this manual. If the load values on the LMI appear to be incorrect, validate the calibration of the Greer TS7 Display unit before proceeding.

When limits are reached, an overload warning is activated. At the same time, the crane movements that would increase the overload condition - such as hoist up, telescope out, and boom down - will be stopped.

To reset the LMI system, retract the boom, elevate the boom, or lower the winch.

If the LMI system must be overridden for any reason, the Cancel Alarm button on the face of the LMI display unit should be depressed for five (5) seconds. At this point, the system is overridden until the overload or ATB condition is removed. For more information on the LMI system, refer to the Description of Machine and Controls section "[Load moment Indicator System](#)".



Abuse or misuse of the ATB/LMI override may result in property damage, serious injury, or death.

## 50-155 M & U

### Operating Instructions

### Maximum Load and Boom Angle Charts

#### Load Handling Operations

Before moving a load, the Operator must study the capacity placards carefully and adhere to the load capacities and radii of the operation given. During operations when lifting, swinging, or extending the load, the controls should always be metered when beginning or terminating movement to prevent sudden starting or stopping. Sudden starts and stops impose undue shock loads on the equipment. This is especially true when handling heavy loads and in extreme cold temperatures in excess of  $-40^{\circ}\text{F}$  ( $-40^{\circ}\text{C}$ ).

#### Maximum Load and Boom Angle Charts

##### Operating Radius

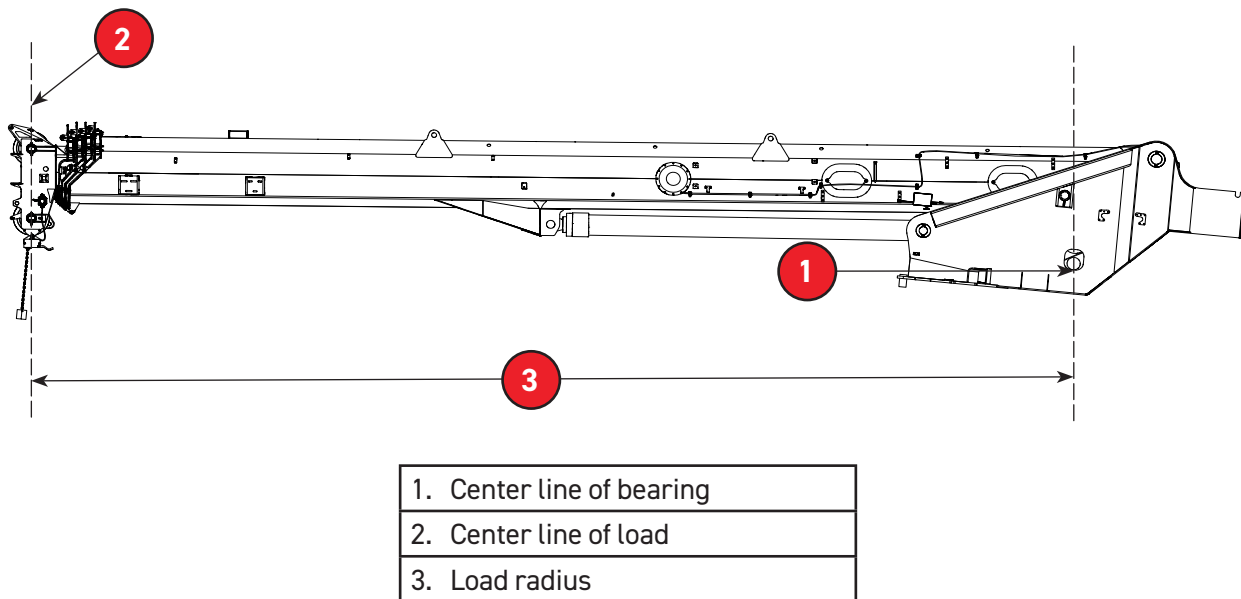

##### Using the Load Chart

The crane load charts list rated loads for various boom lengths and load radii. There are many different load charts depending on the various crane boom modes, counterweight options, outrigger positions, and other considerations. The maximum load that a crane can lift is found on the load chart at the intersection of the boom length and load radius. If the operating radius is between the radii listed on the load chart, use the larger radius. If the operating boom length is between the lengths listed on the load chart, use the longer boom length.

##### Example:

Operating radius                      72 ft  
Operating boom length              105 ft

Looking at the example load chart on the following page, the 72 ft operating radius is between the 70 and 75 ft radii. As a result, this example will use the 75 ft chart radius. The 105 ft boom length is between the 100 and 110 ft chart boom lengths. As a result, use the 110 ft boom length. The crane rated load is located at the intersection of the 75 ft radius row and the 110 ft boom length column. In this example, the crane's current configuration allows it to lift 6550 lbs.

# 50-155 M & U

Operating Instructions  
Maximum Load and Boom Angle Charts



## Operating Boom Length

Operating Radius		39	50	60	70	80	90	100	110	120	130	140	150	155	
	10	100,000								0					
	12	85,350	49,500	48,750	48,300	48,100				0					
	15	71,700	49,500	48,750	48,300	48,100	44,200	38,600		0					
	20	51,150	49,500	48,750	48,000	42,250	37,700	32,950	28,900		25,850				
	25	38,600	40,200	41,050	41,500	36,650	32,450	28,550	25,400	22,450	20,200	17,800			
	30	30,050	31,700	32,550	33,050	32,250	28,300	25,400	22,500	20,000	18,000	16,250	14,500	13,750	
	35		25,600	26,450	26,950	27,300	25,400	22,700	20,100	18,050	16,200	14,700	13,350	12,650	
	40		20,950	21,850	22,350	22,700	22,750	20,400	18,150	16,600	14,850	13,400	12,250	11,800	
	45			18,100	18,550	18,850	19,000	18,450	16,900	15,200	13,600	12,300	11,300	10,900	
	50			14,600	15,000	15,350	15,550	15,600	15,550	13,950	12,600	11,450	10,500	9,900	
	55				12,350	12,650	12,850	12,950	13,000	12,900	11,650	10,500	9,400	8,950	
	60				10,200	10,500	10,700	10,850	10,900	10,900	10,650	9,550	8,550	8,400	
65					8,750	8,950	9,100	9,200	9,200	9,200	8,800	8,150	7,700		
70					7,350	7,550	7,700	7,750	7,800	7,800	7,800	7,450	7,000		
75	0	0	0	0	0	6,350	6,500	6,550	6,650	6,650	6,650	6,600	6,300		
80						5,300	5,450	5,550	5,600	5,650	5,650	5,600	5,350		
85							4,600	4,650	4,750	4,750	4,750	4,750	4,500		
90							3,800	3,900	4,000	4,000	4,000	4,000	3,750		
95								3,250	3,300	3,350	3,350	3,350	3,100		
100								2,650	2,700	2,750	2,800	2,800	2,500		
105										2,200	2,250	2,250	2,000		
110										1,700	1,750	1,800	1,550		
115											1,350	1,350	1,150		
120											950	1,000	1,000		

## 50-155 Load Chart Example

The load chart shows the maximum allowable lifted load. Maximum load is the weight of material being handled plus load handling equipment, such as but not limited to, slings, buckets, and down haul weights. The weight of load handling equipment must be deducted from the maximum load rating to determine how much payload can be lifted.

### Example:

Hook block	750 lbs
Slings	215 lbs
Object being lifted	19,000 lbs
Total lifted load	19,965 lbs



It is important that the Operator knows the weight of any material that they are attempting to handle. This can be determined by the use of a dynamometer or scales.



Swinging of a suspended load can cause the load to drift away from the crane. The drifting of the load away from the crane will increase the crane's operating radius. The increase in operating radius may cause the crane to tip or the boom to fail.



Bouncing or sharp redirection of a load will cause shock-loading to many critical parts of the crane. The shock loads may cause these critical parts to fail.

## 50-155 M & U

### Operating Instructions Boom Angle Placards

#### Boom Angle Placards

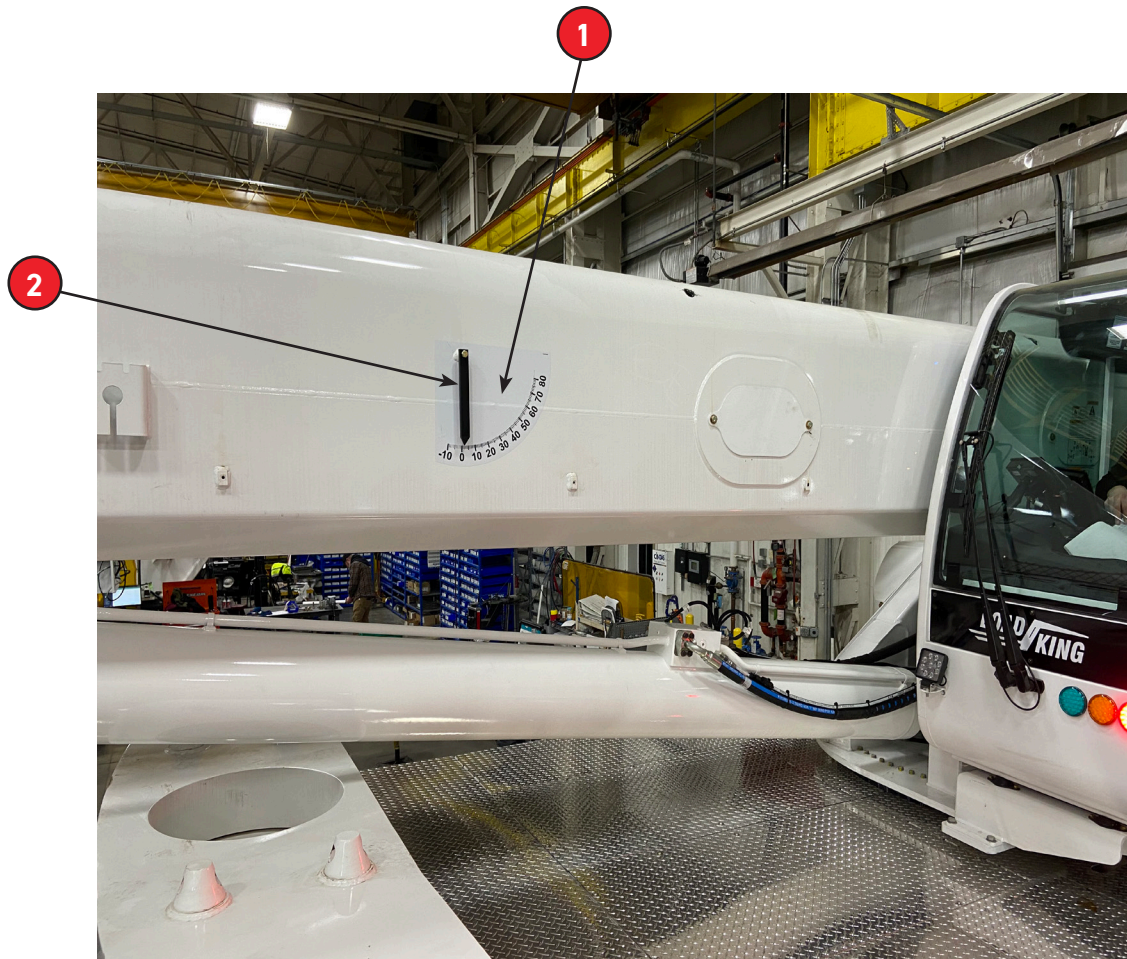

The boom angle placard (1) assists the Operator with information about the safe operating limits of the crane's boom. The placard is located on the boom itself, so that the Operator can easily see the placard while operating the crane. The boom angle indicator (2) will always point directly down, showing on the boom angle placard the general elevation angle that the boom has been raised. This pointer is a general reference only.



It is important to operate the boom within the range shown on the configured load charts to ensure the safe and efficient operation of the crane. Failure to do so can result in damage to the crane or injuries to the Operator and others in the work area.

## 50-155 M & U

Operating Instructions  
Operating the Unit



## Operating the Unit

### Operator Shutoff Devices

#### Anti-Two-Block System (ATB)

Inspect all ATB switches found on the boom, jib, and auxiliary sheave heads for damage. Check the freedom of the weight and chain attached to these switches, and that it is attached around the correct line of hoisting cable in the proper manner. Inspect all electrical connections and wires as well as the entire length of cable attached to the cable reel and its connections for evidence of excessive wear, damage, or improper installation. Check spring-loaded cable reel for proper tension and to insure that reel is free to rotate. Verify operation of the visual and audible warning devices by lifting each of the ATB weights and chains.



When the switch is in the activated position, a warning light will appear on the dash-mounted panel and an audible signal will be heard.

#### Load Moment Indicator (LMI)

The Load Moment Indicator (LMI) will indicate an overload condition with an audible alarm and all boom functions will be disabled except boom-retract, boom-up, and winch-down. To perform a safe and normal crane operation, ensure the load to be lifted is within the acceptable range. Refer to the Operating Instructions section "[Maximum Load and Boom Angle Charts](#)".

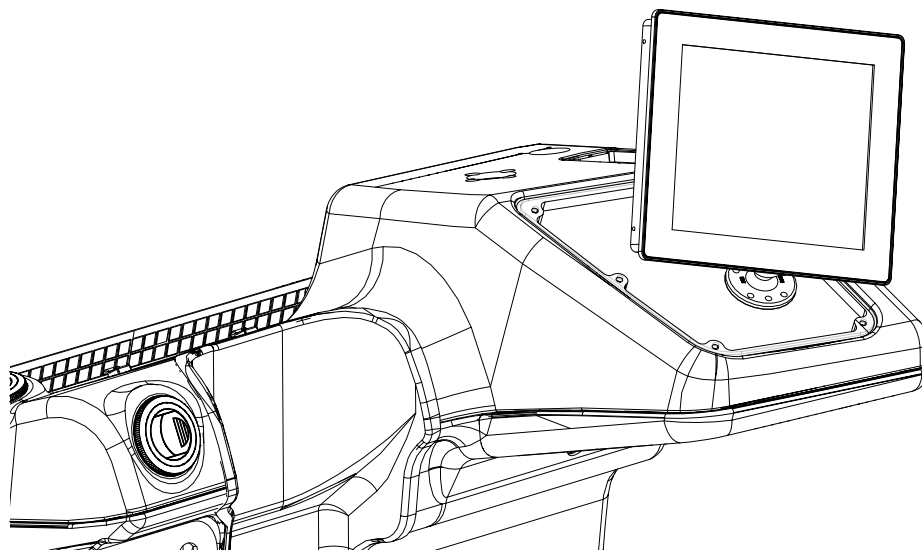

#### State of Load Limit Device







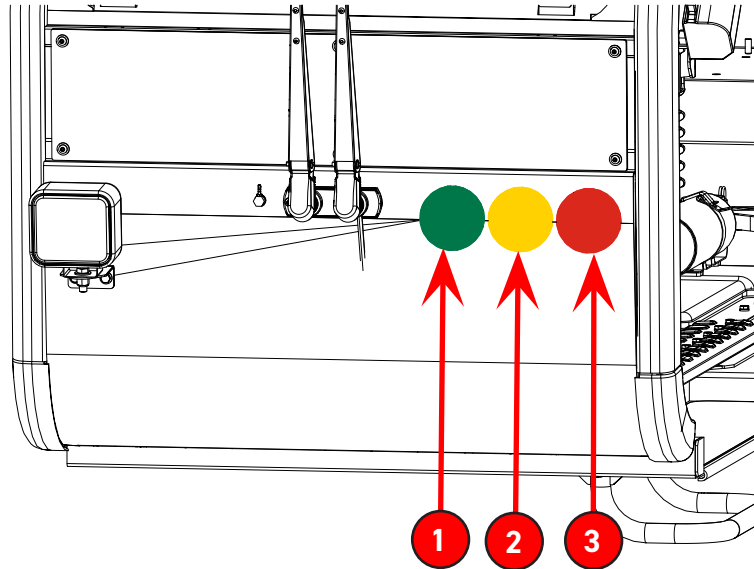

Three load indicator warning lights (1), (2), and (3) are located on the exterior front of the Operator's cab and show the load utilization while the crane is in operation. Visual warning lights are displayed on the Greer TS7 screen for the Operator. When the crane's pre-warning range or overload range is reached, an audible warning buzzer or alarm and siren are activated as shown in the chart below, depending on the load condition. Crane functions come to a full stop when in the Overload Range (from 100%). The overload data is recorded.

# 50-155 M & U

## Operating Instructions

### Operating the Unit



Load	Signals for crane Operators in the crane cab		Signals for people in the danger zone of the crane		Crane Function Kick-Out Movement
	"Crane Operation" Screen	Warning Buzzer	Warning Light	Warning Siren	
<b>Normal Range</b> (below 90%)	Load utilization display (1) green		 Illuminated in green		Crane Functions Normal
<b>Prewarning Range</b> (90% - 100%)	 Warning symbol + Load utilization display (2) yellow	 Sound interrupted	 Illuminated in yellow		Crane Functions Normal
<b>Overload Range</b> (from 100%)	 Warning symbol + Overload display (3) red LLD (red)	 Continuous sound	 Illuminated in red	 Sound interrupted	 Crane Functions Stopped

## 50-155 M & U

Operating Instructions  
Operating the Unit

### Emergency Stop

The red Emergency Stop button (1) is located on the lower part of the dashboard inside the Operator's cab. In case of emergency, push the emergency stop button to the OFF position to stop all crane functions, including engine operation. Rotate the emergency stop clockwise and pull out before resuming normal crane operations.

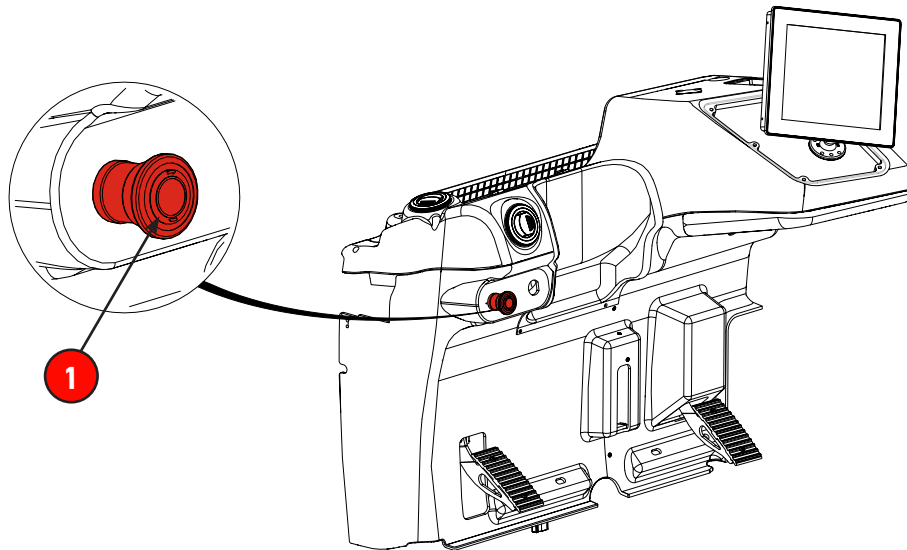

### Third (3rd) Wrap

The winch-down function will be disabled when less than three (3) wraps of rope are available on the winch. The Operator must retract the boom or the winch up.

### Operator's Armrest

When the Operator's left armrest is raised, all joystick functions will be disabled. Lower the armrest to resume normal crane operation.

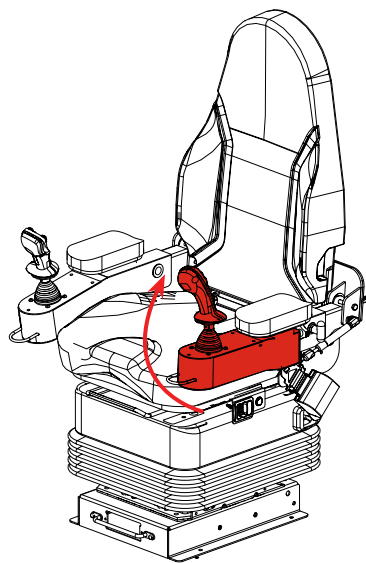

## 50-155 M & U

### Operating Instructions

#### Jump Starting an Engine - Booster Cable Instructions

### Jump Starting an Engine - Booster Cable Instructions

Position the vehicle with the booster battery next to the vehicle with the discharged battery so that booster cables can be easily connected to the batteries in both vehicles. Make certain that the vehicles do not touch. Make certain that both batteries are the same voltage before jump starting.



The engine cannot be started by pushing or towing.

1. Turn off all electrical loads in both vehicles. Apply the parking brake and set the transmission to **PARK** or **NEUTRAL** gear.
2. Determine whether the negative (-) or positive (+) terminals of the discharged battery are connected to ground. The ground lead will be connected to the engine block, the frame, or the chassis. The battery terminal connected to the starter relay is the one that is not grounded.



On most sets of the jumper cables, there is a red (+ positive) cable and a black (- negative) cable.

3. Ensure that the vent caps on both batteries are tight and level. Place a damp cloth over the vent caps of each battery and ensure that it is clear of fan blades, belts, and other moving parts.



The following steps must be performed in sequence:

4. On a negative-grounded system, connect the end of the red jumper cable (+ positive) to the positive (+) terminal of the discharged battery.
5. Connect the opposite end of the red jumper cable (+ positive) to the positive (+) terminal on the booster battery.
6. Connect one end of the black (- negative) cable to the negative (-) terminal of the booster battery.
7. Connect the other end of the cable, away from the battery, to the engine block, frame, or any other metallic ground. Do not connect the cable to the discharged battery vehicle's carburetor or tubing.
8. Make sure that all cables are clear of fan blades, belts, and other moving parts of both engines. Ensure all personnel are standing away from the vehicles. Start the engine with the booster battery. Wait a few minutes allowing the running engine of the vehicle with the booster battery to charge the discharged battery. After the discharged battery has had a chance to receive the charge for a few minutes, attempt to start the engine of the vehicle with the discharged battery.
9. After starting the vehicle with the discharged battery, allow the booster engine to return to idle speed, then remove the cable connections from the engine block or metallic ground. Then remove the other end of the same cable from the booster battery.



Batteries produce explosive gases. These instructions are intended to minimize the explosion hazard. Keep sparks, flames, cigarettes, and other combustibles away from the batteries at all times. Protect your eyes at all times and do not lean over the batteries during this operation.

## Unusual Operating Conditions

Special problems in maintenance and operation are caused by unusual conditions such as extremes in heat, cold and humidity, high altitude, salt water, and dusty or sandy work sites. When operating under such conditions, special precautions must be taken to prevent damage, minimize wear, and avoid component deterioration.

### Extreme Cold

In periods of extreme cold conditions, the issues of freeze damage, inadequate lubrication, and battery failure can be troublesome. With the onset of cold weather, it is advisable to winterize the crane by servicing the cooling system and switching to the lubricants recommended for cold weather usage. Follow the recommendations in this manual when the crane must be operated in very cold conditions.

1. Drain and flush the cooling system to prevent freeze damage to the cooling system and cracking of the engine block or head.
2. Clean the radiator's exterior to ensure that air flows freely through the core and that the cooling fins are free of foreign particles.
3. Refill the cooling system with an antifreeze solution recommended by the engine manufacturer in the amount and strength appropriate for the anticipated temperatures.
4. A corrosion inhibitor is recommended. Refer to the engine manufacturer's recommendations.



Never use a chromate-based corrosion inhibitor if the coolant contains ethylene glycol. Chromate-based inhibitors react with ethylene glycol, they produce chromium hydroxide, also known as "green slime." This substance slows heat transfer and can cause severe engine overheating.

5. Inspect the thermostat, clamps, radiator hoses, and radiator core for proper condition. Replace or repair any defective cooling system components.
6. Maintain the level of fuel at full tank capacity during cold weather conditions to avoid condensation, which can freeze fuel lines and block the fuel flow to the engine.

If water is evident in the fuel supply, drain the tank and refill it with uncontaminated fuel.

7. Lubricate the crane with the lubricants listed on the [Master Lubrication Chart](#) for cold weather operation. If necessary, replace the engine oil and other lubricants according to the manufacturer's recommendations.
8. The battery is more likely to sustain freeze damage if it is not kept fully charged; its electrolytes will freeze at a higher temperature than they would in a fully charged battery. When the engine is running, make sure the battery is charging, and use an external charger to restore full charge when the crane is not in use.

The battery can discharge if snow or ice short-circuits the terminals. Clean and dry the battery posts and cable connectors. Remove any corrosion with a solution of soda and water.

## 50-155 M & U

### Operating Instructions

### Unusual Operating Conditions

It is recommended to remove and store the battery in a heated area when the crane is not in use during extreme cold weather conditions in excess of -40° F (-40° C).



Water added to the battery has the potential to freeze before it mixes with the electrolyte. During extreme cold weather conditions, add water to the battery just before or during crane operation. If the crane is not in use, water may be added if the battery is connected to an external charger.

9. Cold, sluggish oil can cause pump cavitation. If the crane is not equipped with a reservoir immersion heater and running the oil over relief will not warm it enough to prevent pump cavitation with the engine running very slowly, cease attempts to load the hydraulic system until an external heat source can be obtained.

The hydraulic oil may be run over relief to aid in the warm-up process. To achieve this, activate a function, allow the cylinders to reach their limits of travel, and then hold the control in the engaged position for a few seconds.



When running hydraulic oil over relief to warm it, keep the flow as slow as possible by adjusting the pressure on the controls that are engaged and running the engine at low speed.

Warm the oil further by activating all crane functions, actuating all cylinders, swinging the upper, and by operating the winches in both directions.

10. When the crane is not in use, park it on a wood, concrete, asphalt, or mat surface to prevent it from freezing to the ground.

### Extreme Heat

As with extreme cold, extreme heat requires precautions to be taken with respect to the cooling system, battery, and lubrication. When operating the crane in extreme heat conditions, protect the crane by performing the following recommended procedures:

1. High temperatures necessitate the use of lubricants that are more viscous and resist deterioration at higher operating temperatures. Refer to the [Master Lubrication Chart](#) and lubricate the crane with the lubricants recommended for the anticipated temperatures.



Crankcase oil is particularly important because it helps dissipate heat. Check the oil level on a regular basis and add oil as needed to maintain the required level. Heat dissipation will be hindered if there is insufficient oil.

2. To ensure proper coolant circulation, drain and flush the cooling system, clean any foreign matter from the radiator cooling fins and through core air passages. Replace defective hoses, tighten hose clamps, and eliminate any leaks detected. Inspect the water pump drive belt and replace if the belt shows signs of wear. Fill the cooling system with a 50% ethylene glycol solution. A corrosion inhibitor is recommended. Refer to the engine manufacturer's recommendations.

## 50-155 M & U

Operating Instructions  
Unusual Operating Conditions



Allow the engine to cool before draining and flushing the cooling system.

Water containing more than trace amounts of salt or minerals should not be used in the cooling system. Salt facilitates corrosion and the deposition of minerals on the coolant passage walls. Both processes inhibit proper cooling.

3. Air circulation around the engine and battery must not be restricted. Keep the air intake and exhaust openings clear of leaves, paper, or other foreign matter that may restrict airflow.
4. Keep the engine clean of dirt, grease, and other substances that inhibit heat dissipation.
5. Use caution when operating the engine. Avoid the two extremes of racing and lugging.
6. Advance the throttle only enough to handle the load while ensuring that the engine speed is high enough to keep the fan speed adequate for cooling.

### Sandy or Dusty Work Sites

The presence of large amounts of sand or dust at the work site can contribute to accelerated component wear. To address this, frequent lubrication and servicing of breathers and filters at shorter intervals are required.

Increase the frequency of lubrication and service as per the lube chart, refer to Maintenance and Service section "[Master Lubrication Chart](#)". Inspection will determine how long it takes for lubricants, breathers, and filters to accumulate unacceptable amounts of sand or dust. The frequency of lubrication and service should be adjusted accordingly.

### High Humidity or Saltwater

In some locations such as coastal areas, the crane may be exposed to the deteriorating effects of salt or moisture. Follow the recommendations below when operating in these conditions:

1. Always perform frequent inspections for rust and corrosion and remove them as soon as they are detected. Dry and paint exposed surfaces after rust and corrosion have been removed.
2. Where paint may not be applied, such as on polished or machined surfaces, coat the area with grease or lubricant to repel water.
3. Keep bearings and their surrounding surfaces well-lubricated to prevent the entry of water.
4. The hoist rope must be kept well-lubricated to prevent moisture and salt from penetrating the cable strands.

## **50-155 M & U**

Operating Instructions

Unusual Operating Conditions

---

### **High Altitudes**

Variations in altitude alter the fuel/air mixture burned in the engine and affect the engine's performance. At high altitudes, atmospheric pressures are lower, and there is less oxygen available for the combustion of the fuel. At altitudes higher than 10,000 feet above sea level, the engine's fuel injectors may need to be changed to ensure proper performance. Consult the engine manufacturer if any problems arise.

Ensuring that the air cleaner is clean and free of obstructions will help alleviate high altitude problems.

At high altitudes, closely monitor the engine temperature for overheating.

For the air brake systems, in high altitudes it is necessary to drain the accumulated water from the air tanks daily.

# 50-155 M & U

## Operating Instructions Arm and Hand Signals



### Arm and Hand Signals

Many crane functions require that the Operator has an assistant on the ground. This assistant has visibility of possible obstructions and/or hazards and communicates that to the Operator. Clear communication amongst the crew is essential. The following chart shows common standard hand signals and their definitions.

A						
	<b>HOIST</b> Forearm vertical, forefinger pointed up, move hand in small horizontal circles	<b>LOWER</b> Arm extended down, forefinger pointed down, move hand in small horizontal circles.	<b>USE MAIN HOIST</b> Tap fist on head; then use standard signals.	<b>USE AUXILIARY HOIST (Whipline)</b> Tap elbow with one hand; then use standard signals.	<b>RAISE BOOM</b> Arm extended, fingers closed, thumb pointed up.	
	B					
		<b>LOWER BOOM</b> Arm extended, fingers closed, thumb pointed down.	<b>MOVE SLOWLY</b> Use one hand to give any standard motion signal and place other hand motionless in front of hand giving the motion signal. (Hoist slowly shown as example.)	<b>RAISE BOOM AND LOWER LOAD</b> Arm extended, thumb pointed up, flex fingers in and out as long as load movement necessary.	<b>LOWER BOOM AND RAISE LOAD</b> Arm extended, thumb pointed down, flex fingers in and out as long as load movement necessary.	<b>SWING</b> Arm extended, point with finger in direction of swing of boom.
		C				
<b>DOG EVERYTHING</b> Clasp hands in front of body.			<b>EXTEND BOOM (Telescoping Boom)</b> One Hand Signal. One fist in front of chest with thumb tapping chest.	<b>RETRACT BOOM (Telescoping Boom)</b> One Hand Signal. One fist in front of chest, thumb pointing outward and heel of fist tapping chest.	<b>EXTEND BOOM (Telescoping Boom)</b> Both fists in front of body with thumbs pointing outward.	<b>RETRACT BOOM (Telescoping Boom)</b> Both fists in front of body with thumbs pointing toward each other.
D					<h2 style="margin: 0;">HAND SIGNALS</h2> <p style="font-size: 0.8em; margin: 0;">Do not deface or remove this label from the machine. Order replacement labels from your Load King dealer.</p>	
	<b>STOP</b> Arm extended, palm down, move arm back and forth horizontally.		<b>EMERGENCY STOP</b> Both arms extended, palms down, move arms back and forth horizontally.	1006862 REV A		
	1		2	3	4	5

## 50-155 M & U

### Operating Instructions Arm and Hand Signals

	DESCRIPTION OF MOVEMENT
A1	HOIST. Forearm vertical, forefinger pointed up, move hand in small horizontal circles.
A2	LOWER. Arm extended down, forefinger pointed down, move hand in small horizontal circles.
A3	USE MAIN HOIST. Tap fist on head; then use standard signals.
A4	USE AUXILIARY HOIST (Whipline). Tap elbow with one hand; then use standard signals.
A5	RAISE BOOM. Arm extended, fingers closed, thumb pointed up.
B1	LOWER BOOM. Arm extended, fingers closed, thumb pointed down.
B2	MOVE SLOWLY. Use one hand to give any standard motion signal and place other hand motionless in front of hand giving the motion signal. (Hoist slowly shown as example).
B3	RAISE BOOM AND LOWER LOAD. Arm extended, thumb pointed up, flex fingers in and out as long as load movement necessary.
B4	LOWER BOOM AND RAISE LOAD. Arm extended, thumb pointed down, flex fingers in and out as long as load movement necessary.
B5	SWING. Arm extended, point with finger in direction of swing of boom.
C1	DOG EVERYTHING. Clasp hands in front of body.
C2	EXTEND BOOM (Telescoping Boom). One Hand Signal. One fist in front of chest with thumb tapping chest.
C3	RETRACT BOOM (Telescoping Boom). One Hand Signal. One fist in front of chest, thumb pointing outward and heel of first tapping chest.
C4	EXTEND BOOM (Telescoping Boom). Both fists in front of body with thumbs pointing outward.
C5	RETRACT BOOM (Telescoping Boom). Both fists in front of body with thumbs pointing toward each other.
D1	STOP. Arm extended, palm down, move arm back and forth horizontally.
D2	EMERGENCY STOP. Both arms extended, palms down, move arms back and forth horizontally.

## 50-155 M & U

Operating Instructions  
Initiating Operation



### Initiating Operation

1. Position the unit at the job site in such a manner as to ensure all work operations can be performed without repositioning the truck, refer to Operating Instructions section ["Work Site Position"](#). Maximum, load weight, radius, and maximum load rating must always be strictly followed.
2. Set the parking brake.
3. Set the transmission to neutral and engage the PTO. Engage master power switch for the crane.
4. Outriggers can be controlled and set from the upper Operator's cab or from the side of the truck. Refer to Description of Machine and Controls section ["Upper Controls and Instruments"](#) or Operating Instructions section ["Outrigger Positioning"](#).
5. Extend all outriggers to make firm contact with the ground, refer to Operating Instructions section ["Outrigger Positioning"](#). Provide outrigger pads if terrain is soft or if outriggers tend to sink into the ground. Use the master bubble level on the superstructure to properly level the machine. There is a digital level among the controls on the Greer TS7 display while operating the crane, ensure that the proper level condition is maintained at all times.

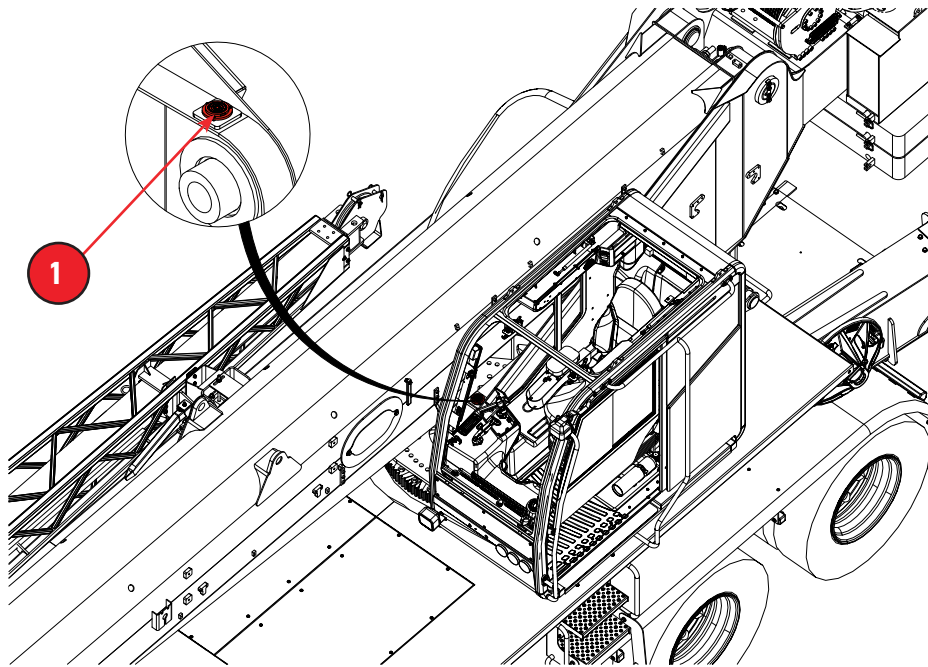

**1. Bubble level with bumpers**

6. Position yourself at the Operator's console and accelerate the truck engine to the desired speed.
7. Bring the hydraulic oil up to its operating temperature, refer to Operating Instructions section ["Cold Weather Operation"](#).
8. Check all controls for proper operation. Controls should be metered during all operations to avoid abrupt starts and stops.



Failure to meter the controls causes high shock loads on the equipment, which can lead to structural failure or crane overturning and may result in serious injury or death.

## 50-155 M & U

### Operating Instructions

### Lifting the Load

## Lifting the Load

Follow recommended procedures for work site position, outrigger positioning, and control metering.

Always inspect down haul weight, load line, hook and any load handling equipment for damage or excessive wear before use.

The following instructions should be adhered to each time a lifting operation is performed.



It is important for the Operator to know the weight of any material that they attempt to handle. This can be determined by the use of a dynamometer or scales.

### Steps to Lifting a Load

1. Determine the total weight of the load.



The total load includes the weight of the material being lifted as well as any material handling devices such as slings, yokes, personnel platforms, load blocks, or jib deducts.

2. Consult the maximum load chart on the crane and determine the correct boom radius and parts of line required based on the load weight using the Greer TS7 (LMI) system.
3. Check the Greer TS7 (LMI) configuration setting number and ensure that it matches the actual crane configuration (including parts of the rigged line).
4. Attach the load line to the material and begin operation. Maintain proper sling or chain usage and ensure that any load handling attachment used is of sufficient size and capacity for the load being lifted.



The Greer TS7 (LMI) system does not protect the crane when the boom is operated below horizontal.

Observe the position of the boom and load at all times. The Greer TS7 (LMI) system does not protect against shock loads or side-loading.



## Making a Typical Lift

Lift procedure: The Operator must successfully coordinate several crane functions when performing lifts. These include the boom raise/lower, boom extend/retract, load hoist/lower, and swing functions. Although experienced Operators tend to perform two or more of these functions simultaneously, the lift procedure can be broken down into the following sequence of operations.

Before beginning any lifting operations, adjust the outriggers as follows:

1. Remove the outrigger beam retaining pins, extend the beams, and reinstall the retaining pins.
2. To set the four (4) outriggers evenly, operate the switches to raise the crane to a level position. When the crane is level, retract the jacks (together) at one end of the crane an inch or so, then extend them (together) again until the crane is level. Repeat this process for the opposite end of the crane. This equalizes pressure in all four jacks. The controls for the out and down outriggers are mounted on the dashboard. The extend/retract master switch must be actuated before the appropriate function switches can be actuated to operate the outriggers.

Before extending the boom or lifting loads, the outrigger beams must be properly positioned for the load rating chart being used, and the crane must be leveled. To achieve this condition, extend the vertical jack cylinders until the tires are raised free of the supporting surface.

	<p>Avoid fully extending the vertical jack cylinders if it is not necessary to level the crane and raise the wheels clear of the ground. Under extreme heat conditions, oil expansion can cause seal failure within the cylinder. Check to ensure that all beams are fully extended, swinging the upper superstructure if necessary to visually check that each beam reaches full extension. Using the IC-1 screen as a reference, level the crane on the X and Y axes relative to 0.0 degrees. While operating the crane, it is necessary to periodically check and level the outriggers between lifts.</p>
	<p>The Operator must exercise sound judgment in positioning the outriggers. The outriggers should not be set near holes, on rocky ground, or on extremely soft ground. Setting the outriggers in such locations may result in the crane tipping, causing personal injury or property damage.</p> <p>There may be situations where firm footing or level ground is not available at the site. In this case, use substantial timbers or structural materials to support the crane's weight (i.e., cribbing). While ensuring that the crane is level, be certain not to exceed the safe bearing capacity of the underlying surface.</p>
	<p>The proper positioning of the outriggers is critical to the safety and efficiency of crane operations.</p>

3. Use the crane's load rating chart to interpret the conditions and limitations that exist when performing a lift with the crane. The determining factors are lifted load weight, radius, boom angle, working position, hoist line reeving, tire pressure, travel data, and use of a jib. The examples in this section are provided to help the Operator interpret the terminology on the load rating chart, refer to Operating Instructions section, "[Using the Load Chart](#)".

	<p>The load rating chart values used in the examples may not be the same as those on your load rating chart. Use the numbers from the chart attached to your crane whenever making a lift calculation.</p>
---	--

## 50-155 M & U

### Operating Instructions

#### Making a Typical Lift

When operating with a greater number of parts of line than is required for the load being lifted, the possibility of inadequate wraps remaining on the winch drum increases, especially at longer boom lengths and high boom angles.

Sufficient wire rope is initially provided to allow the hook block to reach ground level when reeved for the required parts of line indicated on the capacity chart for all given loads. Reeving with more parts of line than required may result in all of the wire rope being payed off the winch drum.



Carefully evaluate the maximum amount of wire rope being paid out from the winch drum while performing the various functions of this crane. At all times maintain no fewer than three (3) full wraps of wire rope on the winch drum, as specified in all applicable crane-operating safety standards.

Observe the warning above closely; the wire rope can break if the wire rope on the winch drum is reverse-wound. Additionally, if the rope wedge in the winch drum becomes unseated, the hook block and load could fall uncontrollably. Using more parts of line than required for the lift increases the likelihood of rope damage.

4. Raise the boom to the required angle, consulting the boom angle indicator which shows the boom angle relative to the upper structure.

The boom elevation is controlled by the right joystick. To raise the boom, slowly move the right joystick to the left. To lower the boom, slowly move the right joystick to the right. Improved control is obtained by operating the engine at low speed while metering the controls. Always operate and release the controls slowly to minimize the dynamic effects of the load. During a lift where precise control of the load is required, do not attempt to use more than one function at a time.



When adjusting the boom height or length, always consider potential obstructions; not just those in front of the cab at the time of the adjustment, but those that may be encountered while swinging the boom.

Before using the swing function, the Operator should think the swing through, considering all obstacles.



Never hold the controls in an activated position once the hoist/lower cylinder or extend/retract cylinders have reached the limits of their travel. This can cause overheating of the hydraulic oil if it is run over relief for prolonged periods.

5. Swing the boom over the load.

The upper structure swing is controlled by the swing joystick on the left. To swing the upper structure to the right (clockwise), move the left joystick in the direction of the required swing, which requires moving the joystick to the right. Move the left joystick to the left to swing left (counter-clockwise). Swing speed increases as the lever is moved further side to side on the left joystick. The swing speed also varies with the engine speed.

Before attempting to swing the upper structure, make sure the swing brake is not set and the swing lock is disengaged. Check that there are no obstacles in the way of the swing.

## 50-155 M & U

### Operating Instructions Making a Typical Lift



Stopping the swing too abruptly will cause the load to oscillate and impose side loads on the boom. Because side-loading can damage the boom, always start and stop swings gradually.

When ready to swing the load, attempt to make it a safe, smooth, and controlled. The swing should be slow. Start the swing slowly and allow the load to build up just enough momentum to carry it through to the point where it is to be lowered.

Begin slowing the swing in advance of the point where the load is to be lowered. Using the swing lever, slow the swing gradually, so that it appears to coast to a stop over the desired spot. Move the lever to the neutral position and then incrementally to the opposite swing direction to slow the swing.

After the swing is stopped, apply the swing brake with the foot pedal. The swing brake can also be used if emergency situations dictate that the swing be terminated abruptly.

If properly executed, the load will hang motionless when the swing is terminated. If the load oscillates, the swing was made too rapidly and/or abruptly stopped.



Never pull sideways with a crane boom. Crane booms are not designed for excessive side pull and may collapse if subjected to excessive side loading.

6. Extend the boom to the desired length. Do not extend the boom further than necessary to perform the lift. Extend the boom by pushing the top portion of the left foot pedal forward, and retract it by pushing the lower part of the left foot pedal rearward.



While extending the boom, be sure to pay out sufficient hoist rope to prevent the hook block from being drawn up to the boom peak. The force of the extend cylinders can easily break the hoist line, dropping the hook block and load, which may result in personal injury or property damage.

The boom extend function on this crane has two positions and two speeds. When the pedal is fully depressed, the regenerative mode increases the engine speed. Increased push is available at reduced engine speed with the pedal approximately halfway forward.

7. Lower the hook block to the load and fasten the hook.

Before lifting any load, ensure that the hook is properly engaged with the slings or lifting device being used. Ensure that the hook latch is not supporting any of the load.



A hook latch is intended to retain loose slings or devices under slack conditions. It is not intended to be an anti-fouling device, so caution should be used to prevent the latch from supporting any weight of the load. The latch must be inspected on a regular basis to ensure proper operation.

Hoisting or lowering of the load with the main winch is controlled by the right joystick. Lower the load by pushing the right joystick forward and raise the load by pulling the right joystick back. Improved control is obtained by operating the engine at a low speed while metering the control. Always actuate and release the joystick slowly to minimize the dynamic effects of the load and to prevent "bird nesting" of the cable on the winch drum.

## 50-155 M & U

### Operating Instructions Making a Typical Lift

To shift the main winch into high-speed mode, select high-speed using the two-speed switch located on the upper portion of the right joystick. Slowly return the winch lever to its neutral position to gradually bring the load to a stop. The main winch can be disabled by selecting the center switch on the right joystick.

Hoisting or lowering of the load with the auxiliary winch is controlled by the left joystick. Lower the load by pushing the left joystick forward and raise the load by pulling the left joystick back. Improved control is obtained by operating the engine at a low speed while metering the control. Always actuate and release the joystick slowly to minimize the dynamic effects of the load and to prevent “bird nesting” of the cable on the winch drum.

To shift the auxiliary winch into high-speed mode, select high-speed using the two-speed switch located on the upper portion of the left joystick. Slowly return the winch lever to its neutral position to gradually bring the load to a stop. The auxiliary winch can be disabled by selecting the center switch on the left joystick.

8. Lift the load to the desired height. As a good operating practice, do not lift the load any higher than necessary.

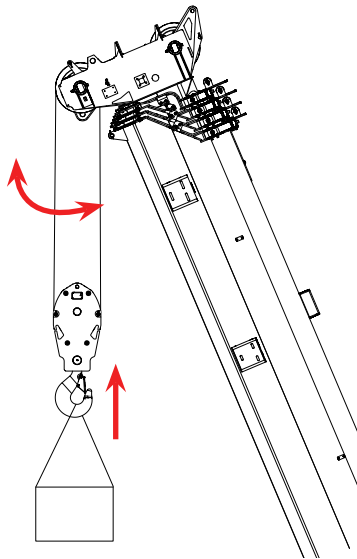

The crane is equipped with an Anti-Two-Blocking (ATB) system, which includes a warning light, an audible alarm, and control disconnects. When the hook block or ball activates a correctly installed and maintained ATB system, the block or ball will not raise, the boom cannot be extended, and the boom cannot be lowered. To return to an operating condition, either lower the hook or ball, retract, or raise the boom.

The Operator may need to raise the hook block beyond the point at which the ATB system is activated during rigging or travel. In these instances, the Operator may override the system. For more information, refer to Description of Machine and Controls section “[Carrier Controls and Instruments](#)”.



Continuing to pull the block up after making contact with the boom head may cause damage to the boom head and sheaves or break the cable, causing the load to drop.

9. Swing and spot the load over the location where it is to be deposited.

## 50-155 M & U

### Operating Instructions Making a Typical Lift



10. Lower the load and unfasten the hook.



When spotting the load, the boom length or boom angle may need to be adjusted. The Operator must be careful not to exceed the rated load as determined by the load rating chart when making these adjustments.

When operating a hydraulic crane, the Operator should be aware that hydraulic and structural competence, rather than tipping load, is often the determinant of lifting capacity. As a result, when considering load weight, the Operator must rely solely on the appropriate manufacturer's load rating chart.



Never exceed the manufacturer's rated loads.

Cranes that are factory-equipped with auxiliary winches may require additional counterweight if the auxiliary winch is removed. Refer to the capacity chart (load rating plate) for the required counterweight total.



Maintain sufficient cable tension when lowering light loads to prevent the cable from becoming loose on the cable drum. A slack cable can slip and then bind abruptly, resulting in jerky lowering and shock loading of the boom. When the cable is wound onto the winch drum, loose wraps can form loops that can be overlain. These conditions can cause personal injury or property damage.

## 50-155 M & U

### Operating Instructions Moving the Unit

## Moving the Unit

### Removable Counterweight



The counterweight slabs are an integral part of this crane. When the crane is driven, the counterweight slabs may need to be moved from the upper frame to the deck, or removed from the crane to meet local weight restrictions and axle weight limits.

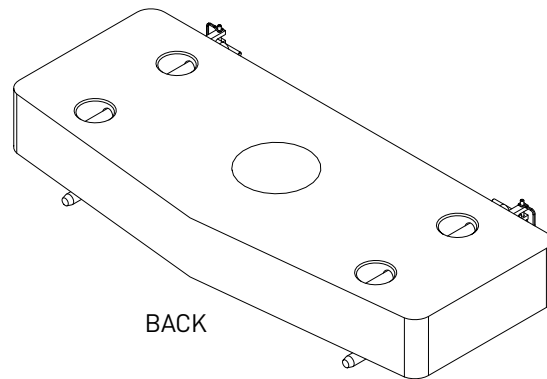
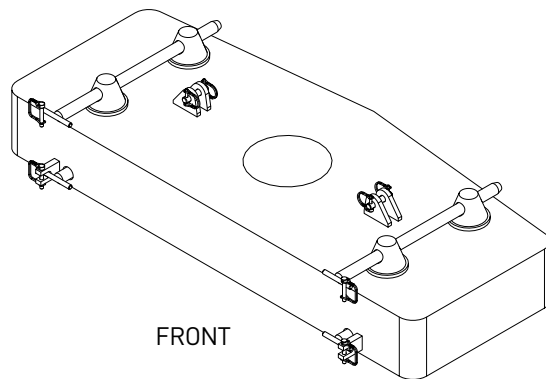

1. All of the counterweight slabs cannot be stored on the deck during transport. The configuration of the slab stack on the deck and the back of the superstructure may vary based on axle/weight ratios for lifting and transport purposes. If the full stack of slabs remains on the deck during transport, it is possible this stack will contact the lift cylinder, resulting in damage to the lift cylinder.

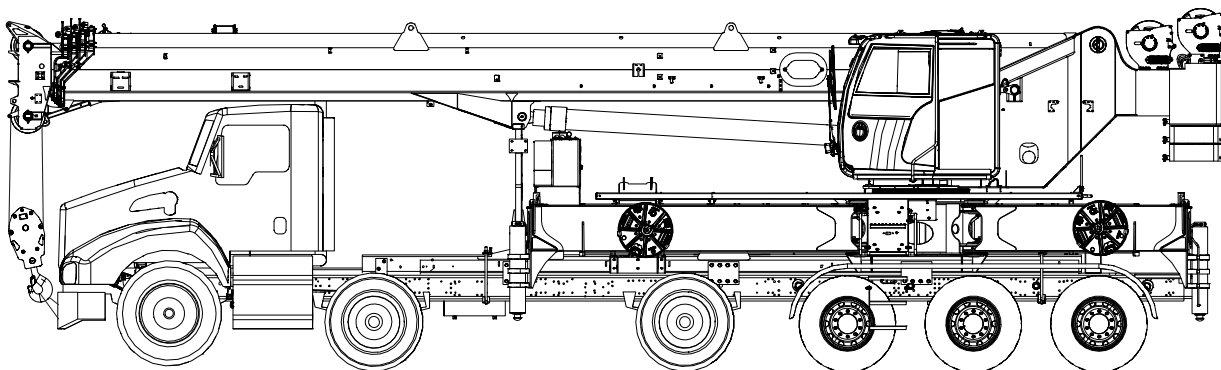



The boom hoist bracket may incur considerable damage if the boom is placed on the boom rest with all counterweight stacks on the decking.

2. Fully extend the outrigger beams, lower the outrigger jacks, and level the crane. There is a level indicator that can guide the Operator when leveling the crane.

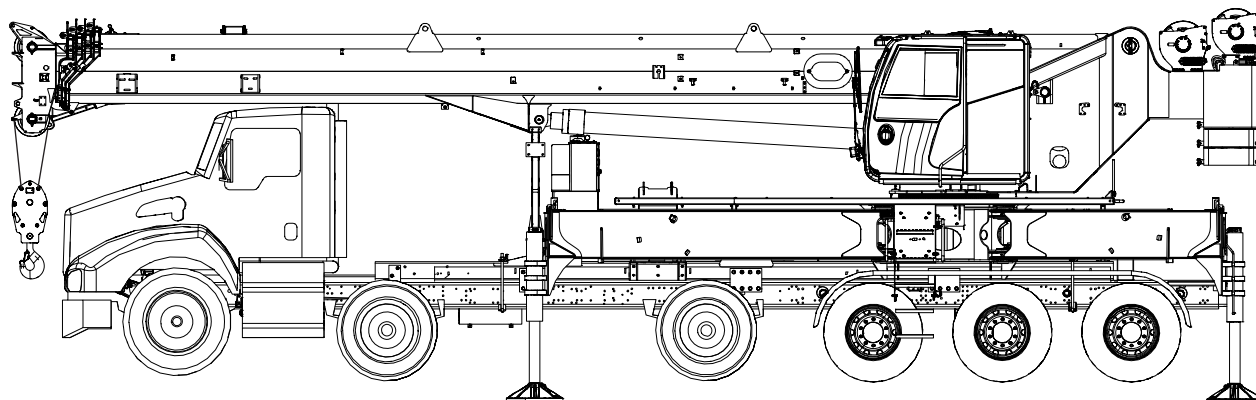

## 50-155 M & U

### Operating Instructions Moving the Unit

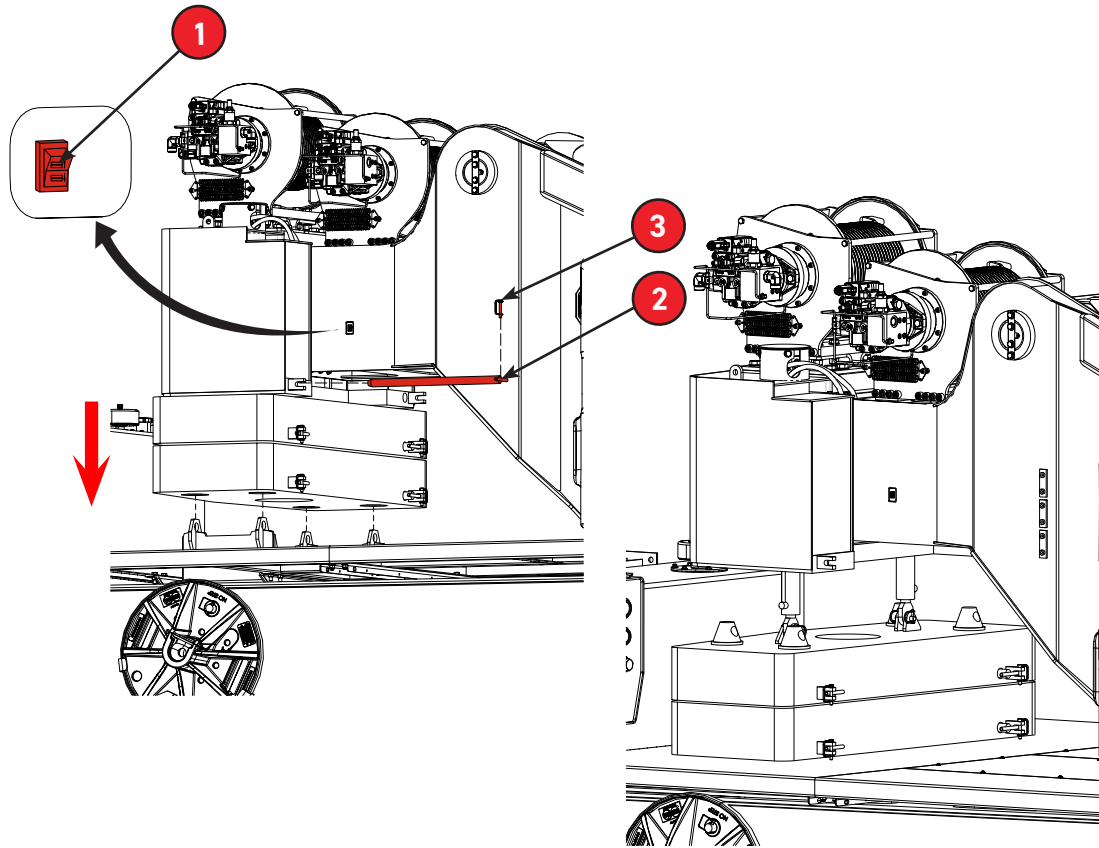

3. While the crane is running, use the rocker switch (1) to raise or lower the crane to an alignment with the counterweight.
4. Move the rocker switch (1) to the RAISE position to lift the stack up and get the counterweight loaded on the lift cylinders.
5. Remove the cotter pins (3) and the long horizontal counterweight mechanical stop pins (2). Both pins will pull out freely.
6. The counterweight cylinders can now be lowered by moving the rocker switch (1) to the LOWER position. The counterweight will be lowered onto the decking's triangular guides.



Do not continue to extend cylinders after the counterweight is resting on the deck. Severe damage may occur to the cylinders or cylinder mounts.

7. Remove the counterweight locking pins to keep the stack on the decking.



If one or both pins will not release, it may be necessary to slightly lower one side of the slabs while raising the other to remove the first pin, then slightly lower the side that is still pinned while pulling the other side up tightly to remove the second pin.

## 50-155 M & U

Jib Deployment and Stowage  
Deploying the Jib



### Jib Deployment and Stowage

The jib option is a 32 ft. to 49 ft. manually-extended push-pull stinger jib.

This jib can be offset by 0, 15, or 30 degrees.

The jib can be deployed in 2 basic configurations:

- o Base lattice section only
- o Base lattice and manually-extended push-pull stinger sections

### Deploying the Jib

The following procedure should be done by the Operator using the hand-held remote, or by an Operator in the cab with help from someone on the ground outside the crane. This person should be able to observe the pins aligning and direct the crane Operator.

1. Extend and set the outriggers to mid-full span, and level the machine.
2. Rotate the upper superstructure to the over-rear position.

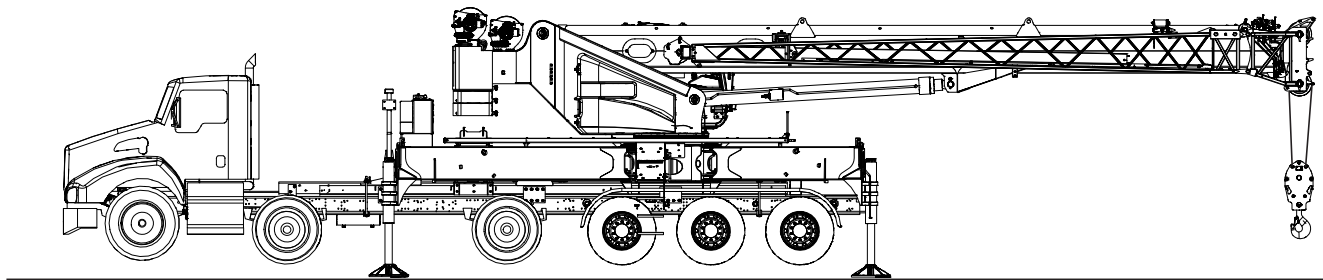

3. Retract the boom completely.

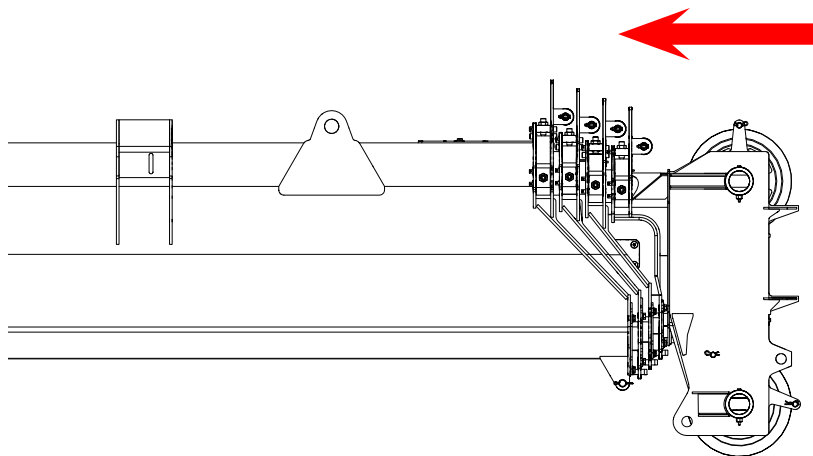

## 50-155 M & U

### Jib Deployment and Stowage

#### Deploying the Jib

4. Lower the boom to the minimum boom angle. This will put the boom at an angle of 5 to 10 degrees below horizontal to ease installation of the jib pins.

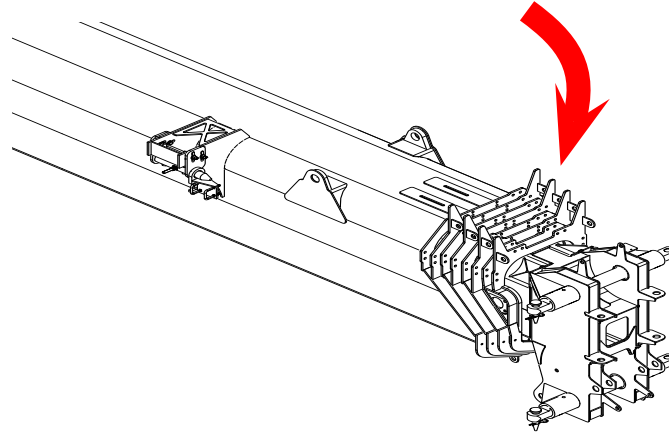

5. If there is an auxiliary cable, remove the auxiliary cable from the boom head and move the cable over the left side of the boom head so that it is behind the boom head pins. Otherwise, remove the main cable from the boom head and move it over the left side of the boom head so that it is behind the boom head pins.
6. Extend the boom until the holes for the first set of pins align with the corresponding jib holes. This should be done by an Operator in the cab with help from someone outside the crane that can observe the pins aligning- OR- by the Operator using the hand-held remote.

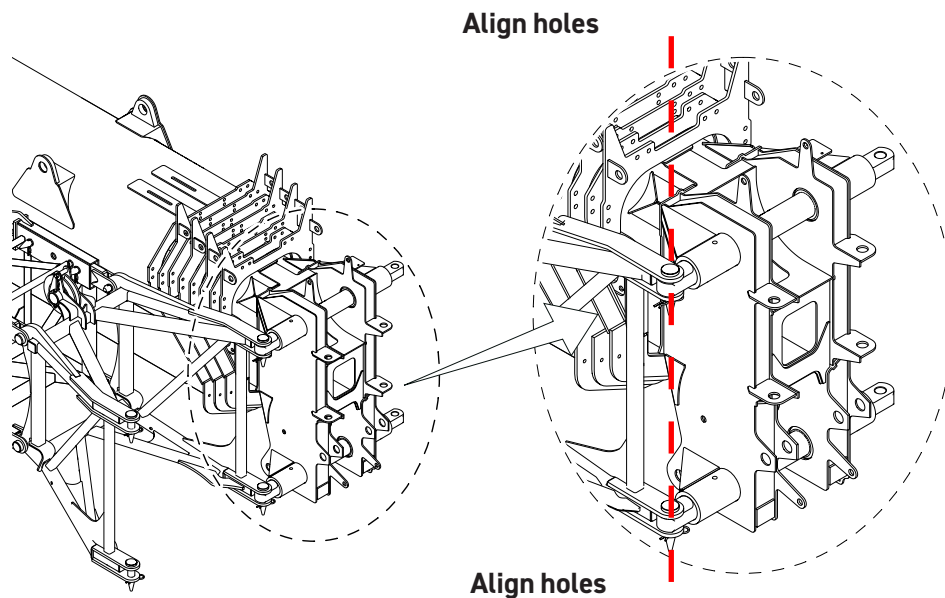

## 50-155 M & U

Jib Deployment and Stowage  
Deploying the Jib

7. Install the upper and lower jib mounting pins (1 & 2) in the pivoting side of the boom head. Ensure the pins are fully engaged and then secure the top and bottom pins with the provided cotter pins.

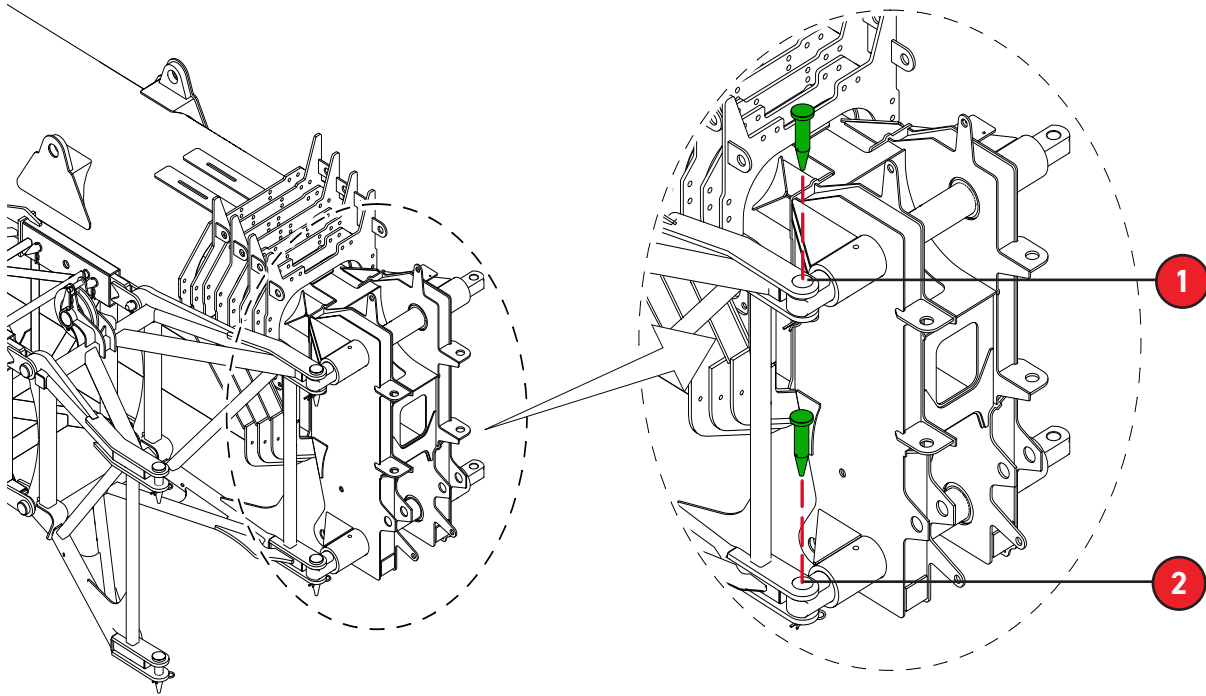

8. Attach a tag line to the eye (A) on the bottom tip of the jib.

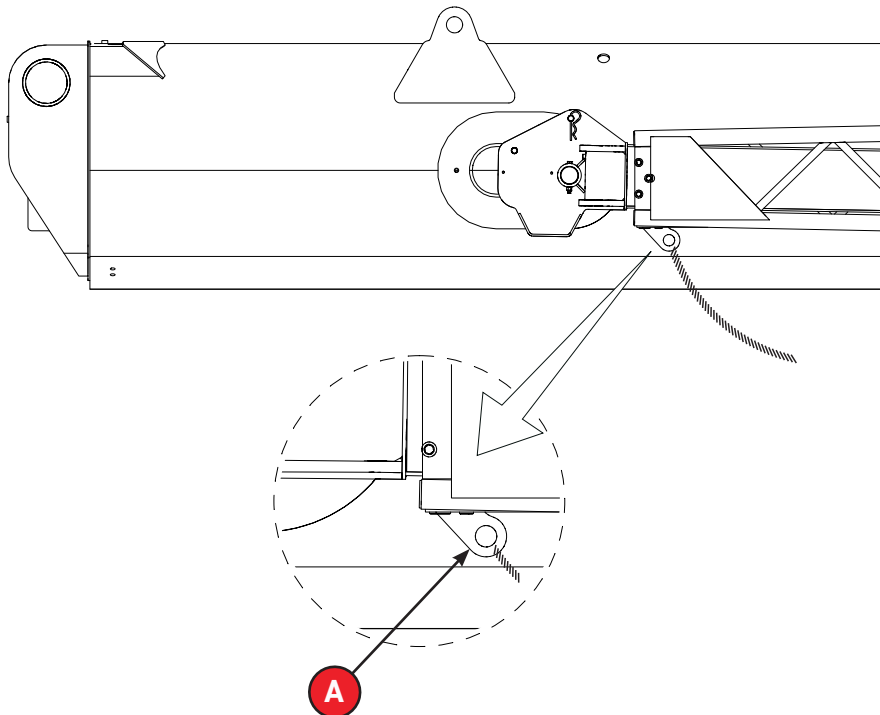

## 50-155 M & U

### Jib Deployment and Stowage

#### Deploying the Jib

9. Check to ensure pin holding the stinger (**B**) is present and properly engaged.



If the stinger is not secured, it may slide out while the boom is extended, causing serious injury or death.

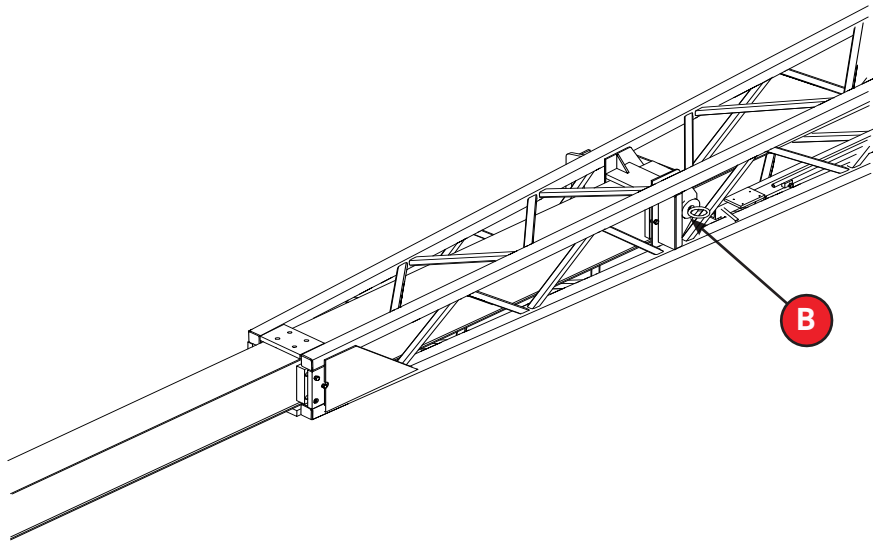

10. Pull down and rotate the T-handle (**C**) to unlock the jib from the stowage bracket. The T-handle will stay in the unlocked position until rotated back 90 degrees.

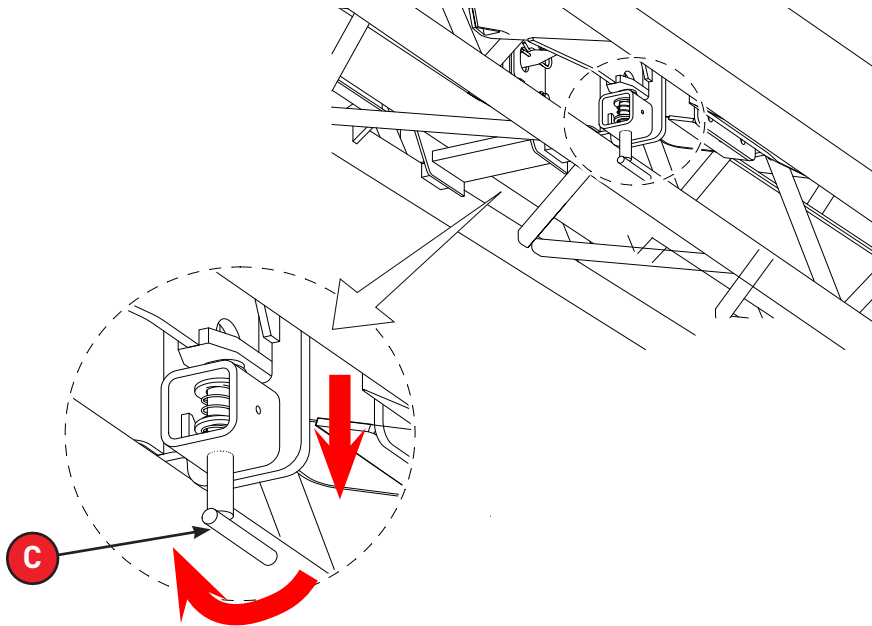

## 50-155 M & U

Jib Deployment and Stowage  
Deploying the Jib

11. Raise the boom to approximately 30 degrees.

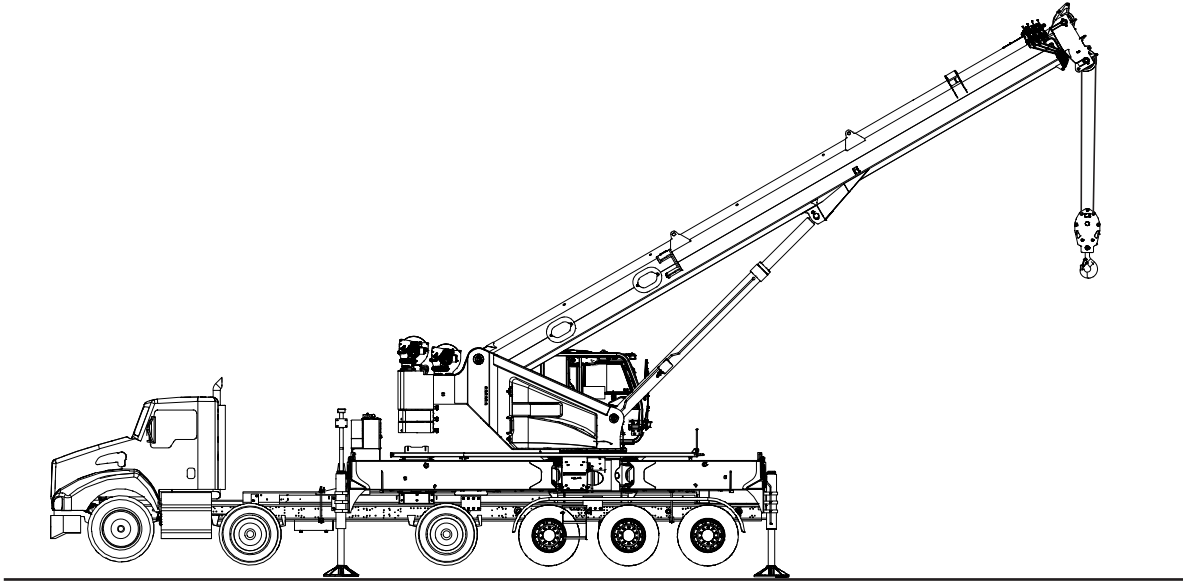

12. Slowly extend the boom 2 to 3 feet (0.6-1m). As the end of the jib clears the stowage brackets, the jib will be free to swing clear of the brackets. The jib should be controlled with the tag line as it swings free.



A fast-swinging jib assembly can cause serious injury or death.

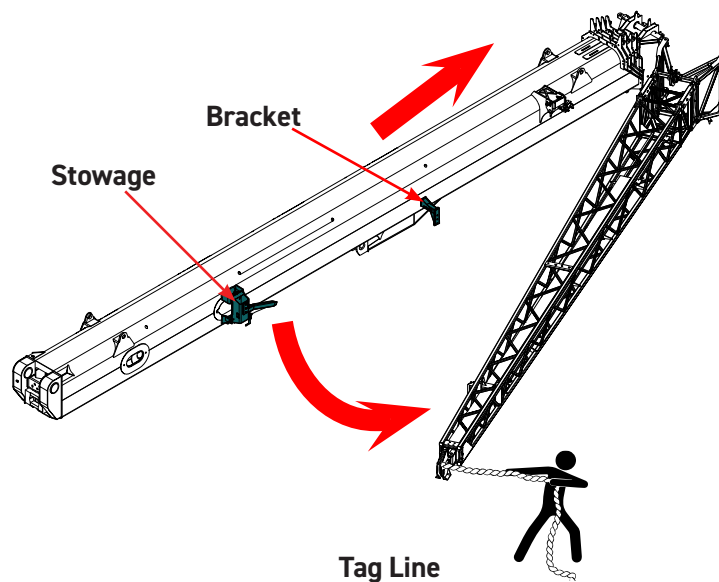

## 50-155 M & U

### Jib Deployment and Stowage

#### Deploying the Jib

- Using the tag line, swing the jib out approximately 15 degrees. Then fully retract the boom, ensuring that the jib does not re-engage with its stowage brackets. This engages anti-twist plates in each boom section to resist the boom twisting while the jib is rotated to deploy or to the stowage positions.

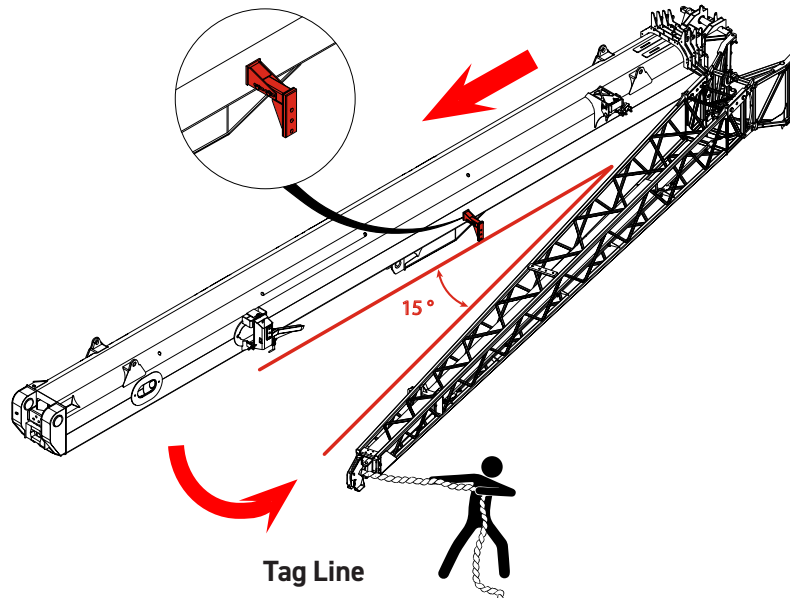

- Slowly lower the boom to the minimum boom angle. While using the tag line to control the speed of the jib rotation, swing the jib around until the left side mounting holes line up.

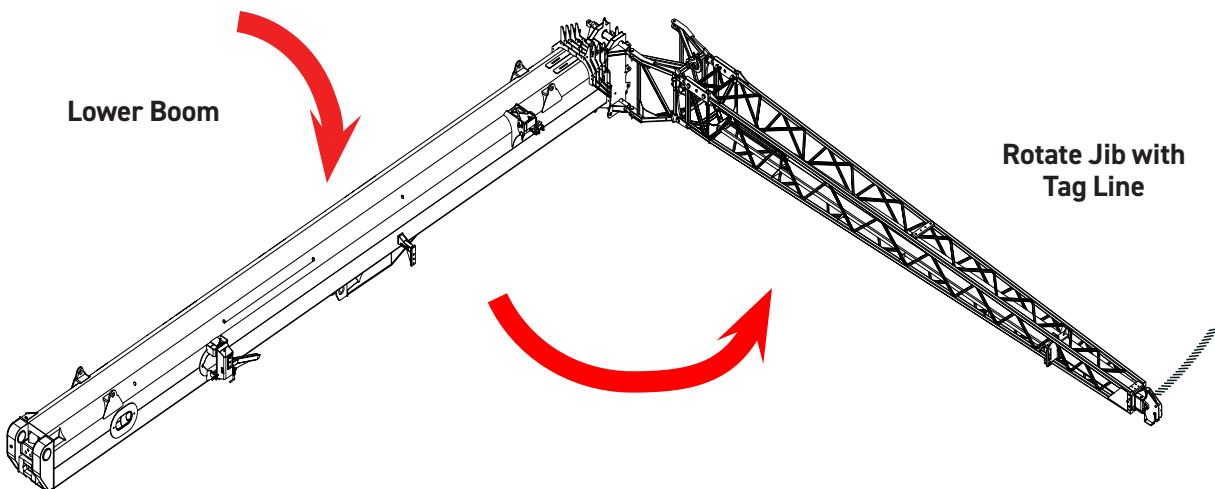

## 50-155 M & U

Jib Deployment and Stowage

Deploying the Jib

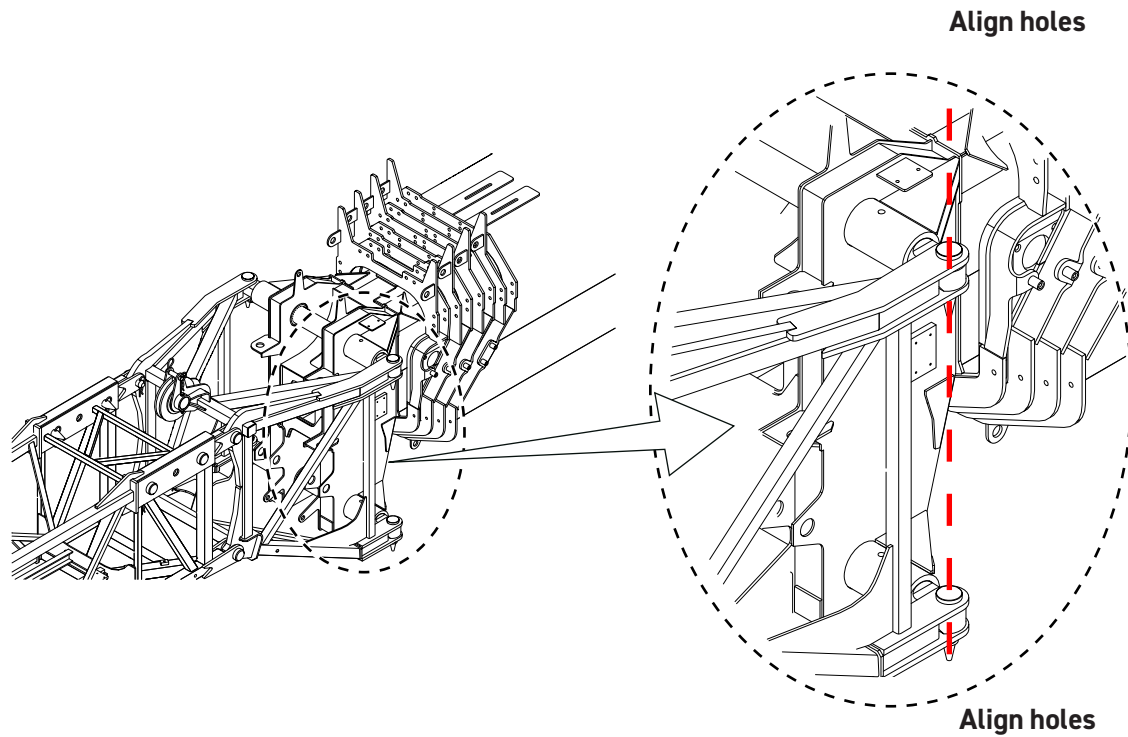

Lowering the boom too quickly can result in damage to the jib.

## 50-155 M & U

### Jib Deployment and Stowage

#### Deploying the Jib

15. Install the left lower (3) and upper (4) jib mounting pins. Secure the pins with the provided cotter pins. If it is difficult to align the holes for insertion of the fourth (4th) pin, it may be necessary to use a rope to pull the jib up to provide leverage and enable alignment of the pin holes for the pin insertion. (Refer to [Routing the Winch Rope for Fourth \(4th\) Pin Alignment](#) Instructions) If using the rope for fourth pin alignment, detach the rope from the lifting eye after installing the pin.

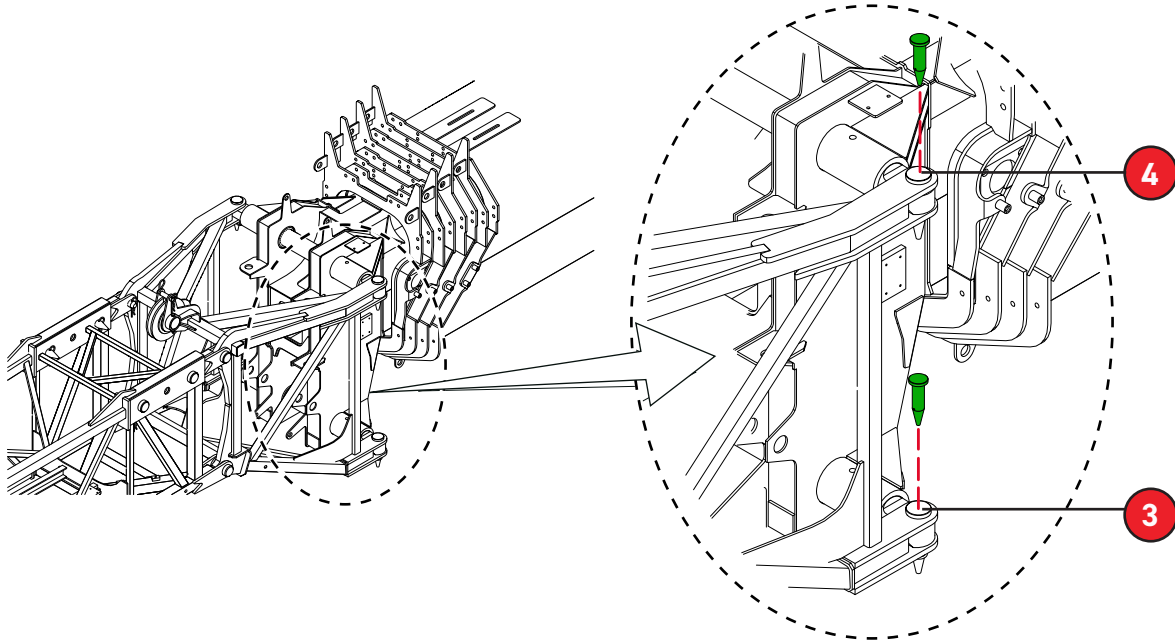

16. Remove the tag line from the jib.

## 50-155 M & U

Jib Deployment and Stowage  
Deploying the Jib

17. Move the plug from the boom head socket (D) to the ATB socket on the aux head as it is equipped.

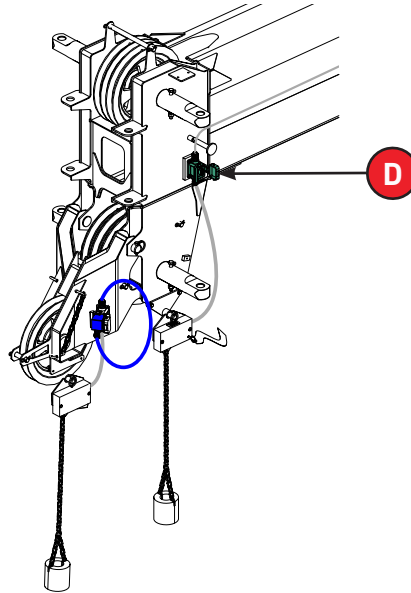

18. Disconnect the ATB plug from the jib base-end ATB socket (E) and connect it to the socket on the boom head.

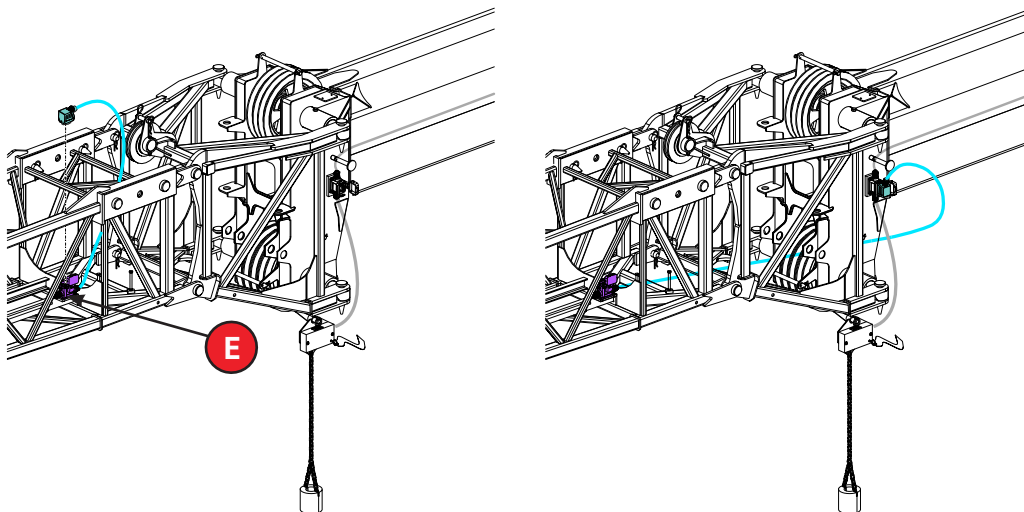

19. Reeve the hoist line over the jib sheave and clamp the ATB weight to the hoist line and jib tip switch.
20. Test the ATB system by lifting the ATB weight. The light and audible alarm should be actuated in the cab and the boom-down, boom-extend, and winch-up controls should disconnect.

## 50-155 M & U

Jib Deployment and Stowage  
Extending the Stinger

### Extending the Stinger



Extending the stinger when jib is in stowed position may cause damage to the jib.

1. Set up the crane on fully-extended outriggers to full extension and level the unit.
2. Rotate the upper structure to the over-rear position.
3. Fully retract the boom.
4. Lower the boom to the minimum boom angle to allow ease of stinger extension.
5. Attach the winch rope beckett to the anchor point on the bottom of the jib tip.

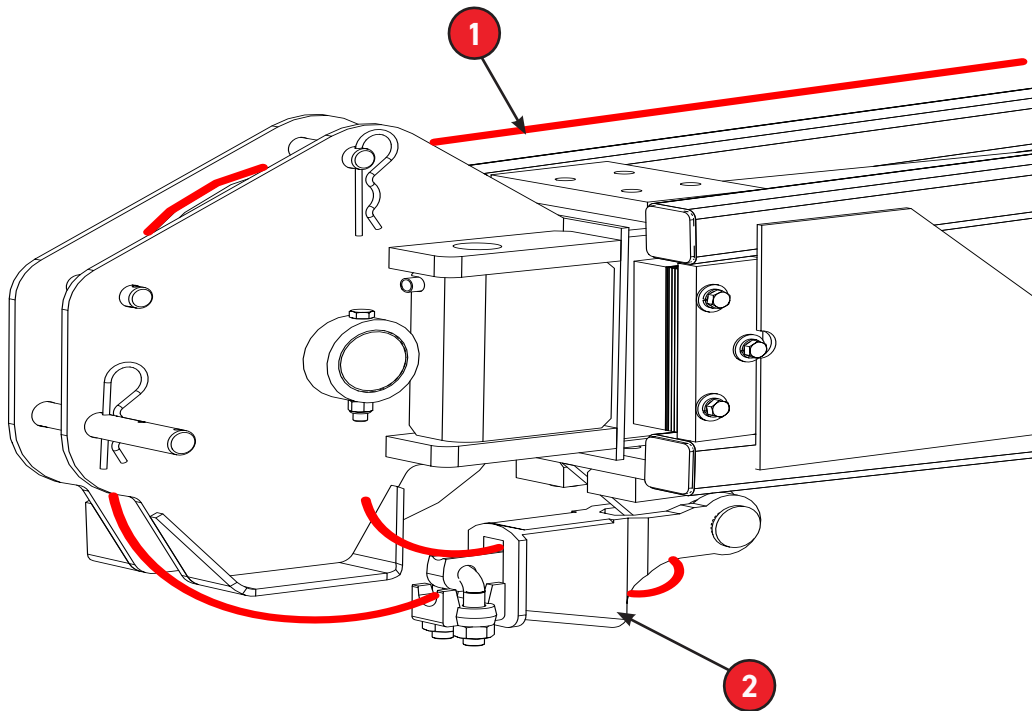

1. Winch Rope

2. Beckett



Always control the winch rope during this procedure.

## 50-155 M & U

Jib Deployment and Stowage  
Extending the Stinger

6. Unplug the stinger Anti-Two-Block (ATB) plug (F) from the Anti-Two-Block (ATB) retracted socket. Failure to unplug before extending the stinger will damage the ATB wiring.

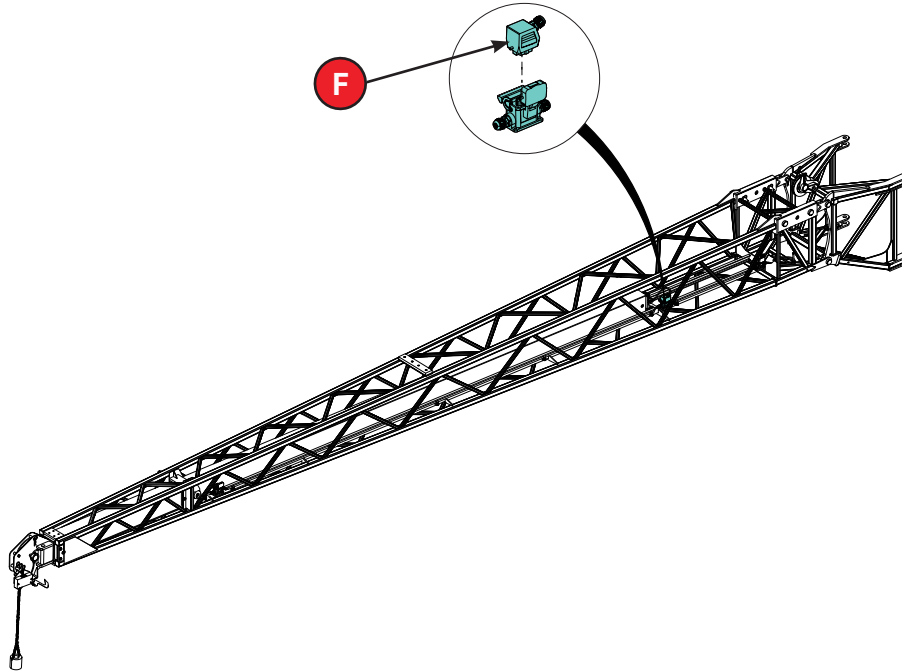

7. Remove the pullout retaining pin (B) from the retaining pin hole. If stinger resists sliding out, use tag line to assist pulling stinger out.

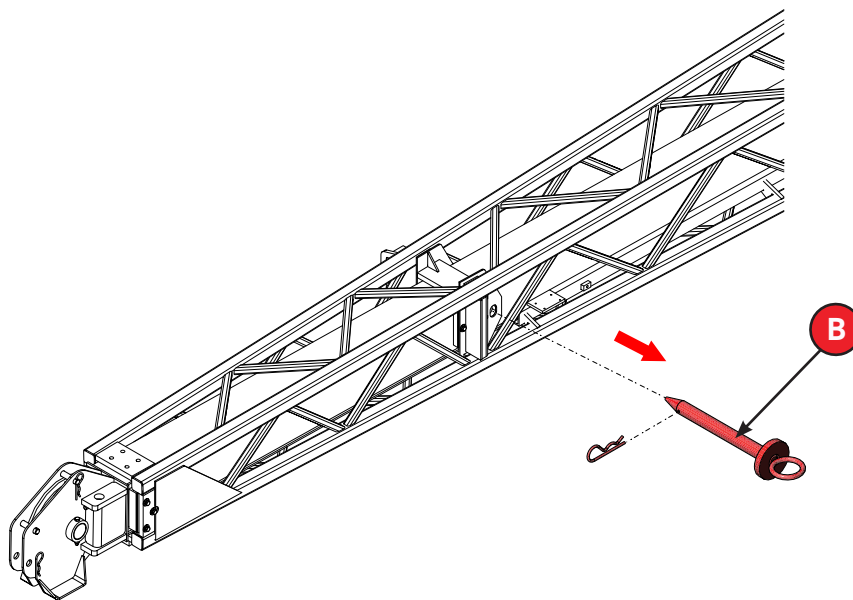

## 50-155 M & U

### Jib Deployment and Stowage Extending the Stinger

8. Pay out the winch cable, allowing the stinger to extend until the retaining pin holes line up.

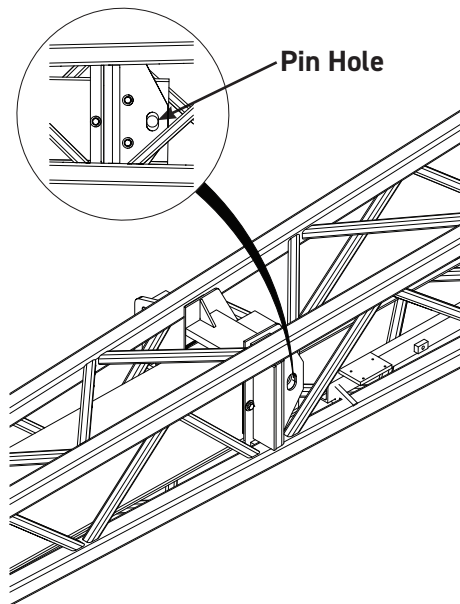

9. Install the retaining pin (**B**) at the rear pin hole of the stinger.

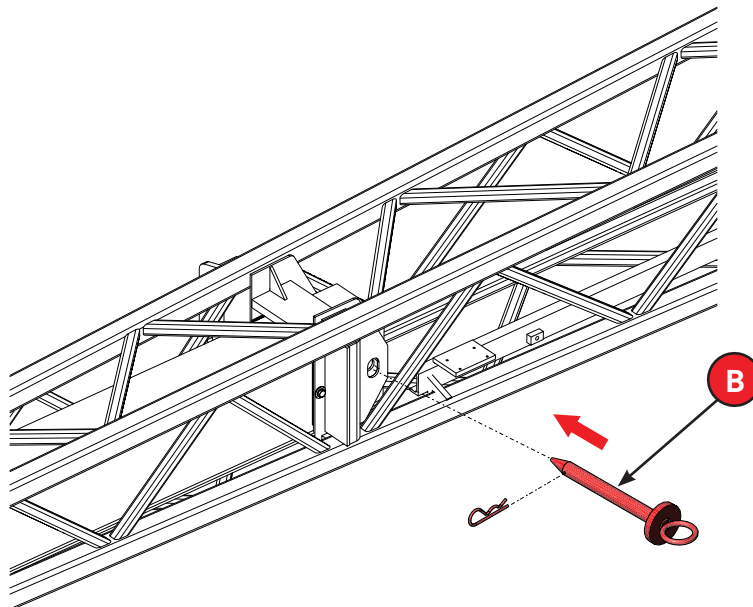

## 50-155 M & U

Jib Deployment and Stowage  
Extending the Stinger

10. Plug the Anti-Two-Block (ATB) plug (F) from the rear section of the stinger extension into the Anti-Two-Block (ATB) extended socket, located near the retaining pin (B).

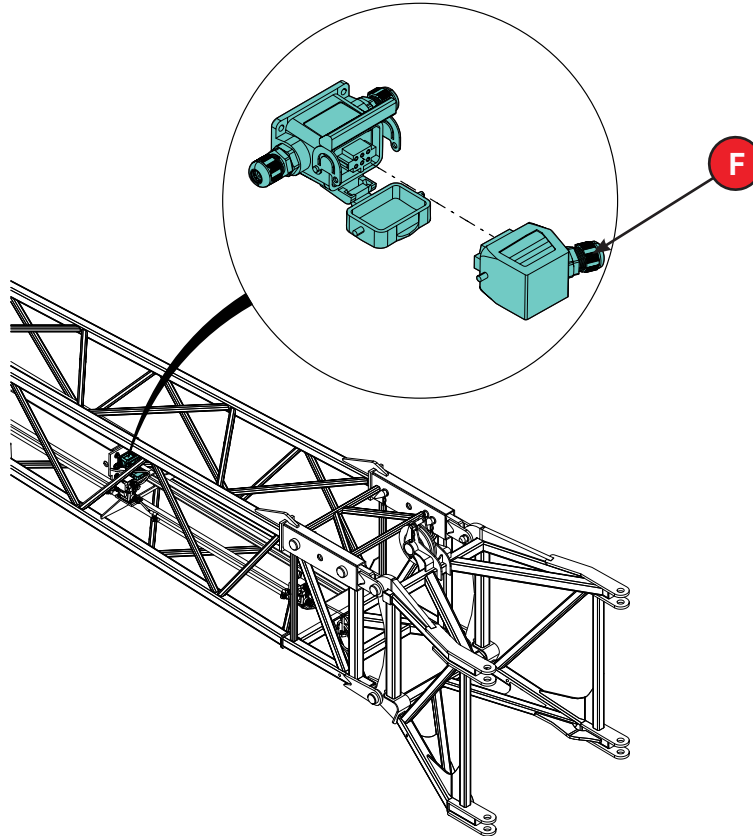

11. Remove the tag line from the anchor point on the bottom of the jib.
12. Reeve the hoist line over the stinger head sheave.
13. Test the Anti-Two-Block (ATB) system by lifting the Anti-Two-Block (ATB) weight. The light and audible alarms should be actuated in the cab and the boom-down, boom-extend, and winch-up controls should disconnect.

## 50-155 M & U

Jib Deployment and Stowage  
Retracting the Stinger

### Retracting the Stinger

1. Fully retract the boom.
2. Lower the boom to the minimum boom angle to allow ease of installation of the retaining pin.
3. Attach the dead end of the tag line to the anchor point on the bottom of the jib tip.



Always control the winch rope during this procedure.

4. Unplug the extended jib Anti-Two-Block (ATB) plug (F) from the socket.

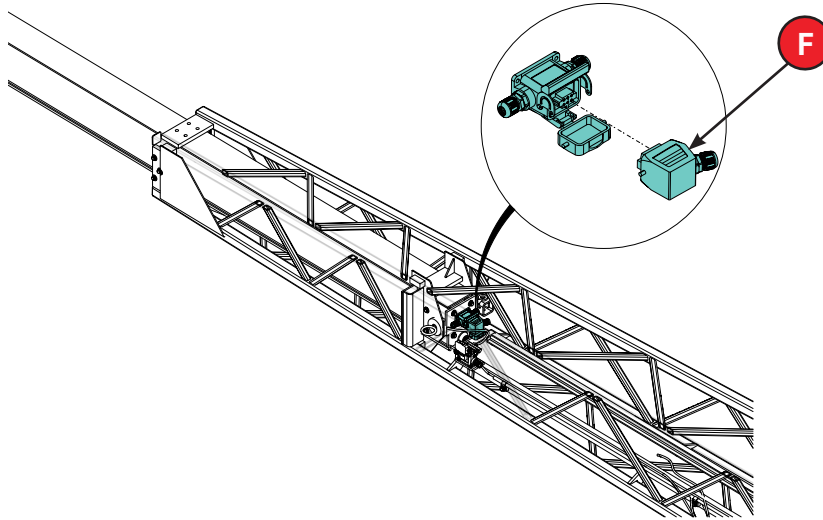

5. Remove the pullout retaining pin (B) from the extended retaining pin hole.

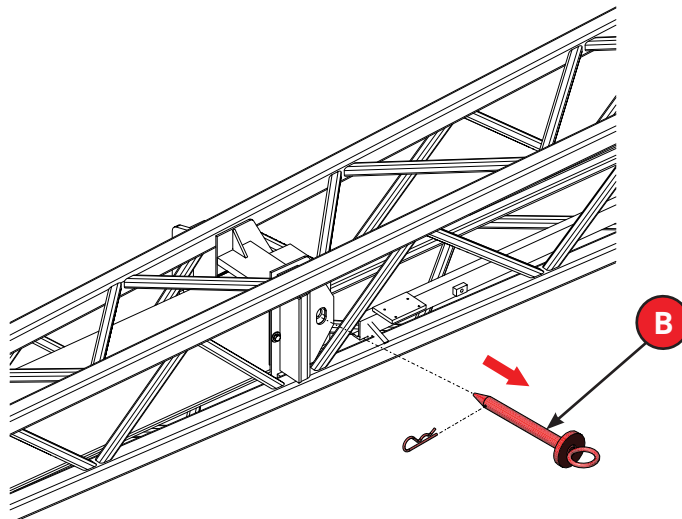

## 50-155 M & U

Jib Deployment and Stowage  
Retracting the Stinger

6. Carefully winch up to pull the jib extension stinger until the hole in the stinger aligns with the pin hole.

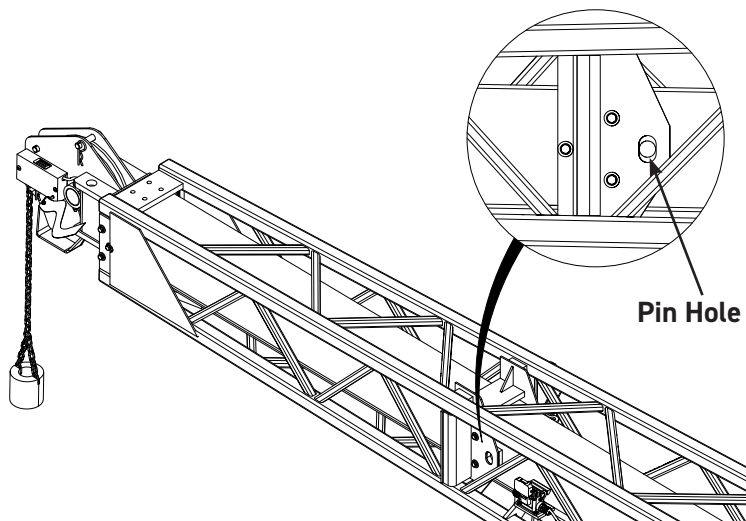

7. Install the pullout retaining pin (B) in the retaining pin hole.

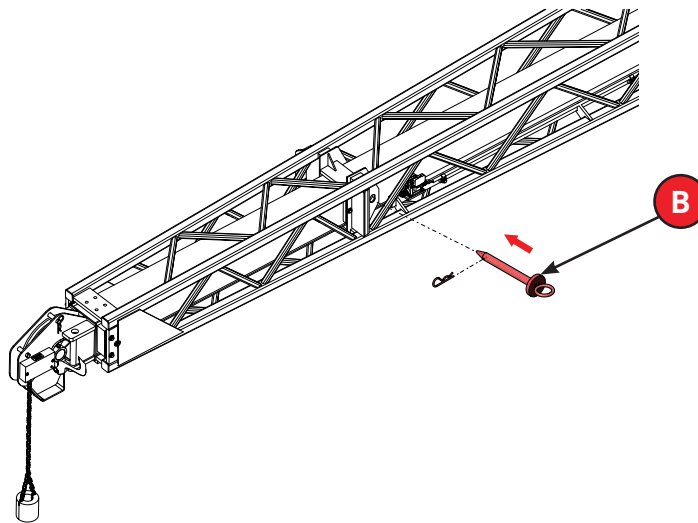

8. Connect the ATB plug at the lattice base to the rear connection on the extension stinger section.
9. Test the Anti-Two-Block (ATB) system by lifting the Anti-Two-Block (ATB) weight. The light and audible alarms should be actuated in the cab and the boom-down, boom-extend, and winch-up controls should be disconnect.
10. Remove the winch rope from the anchor point on the bottom of the jib and route over jib tip sheave to the ball/block.

## 50-155 M & U

### Jib Deployment and Stowage

#### Routing the Winch Rope for Fourth (4th) Pin Alignment

### Routing the Winch Rope for Fourth (4th) Pin Alignment

1. Route the winch rope taken from the boom head over the roller and lattice head sheave.
2. Attach the winch rope beckett to the anchor point (A) behind the lattice head sheave.

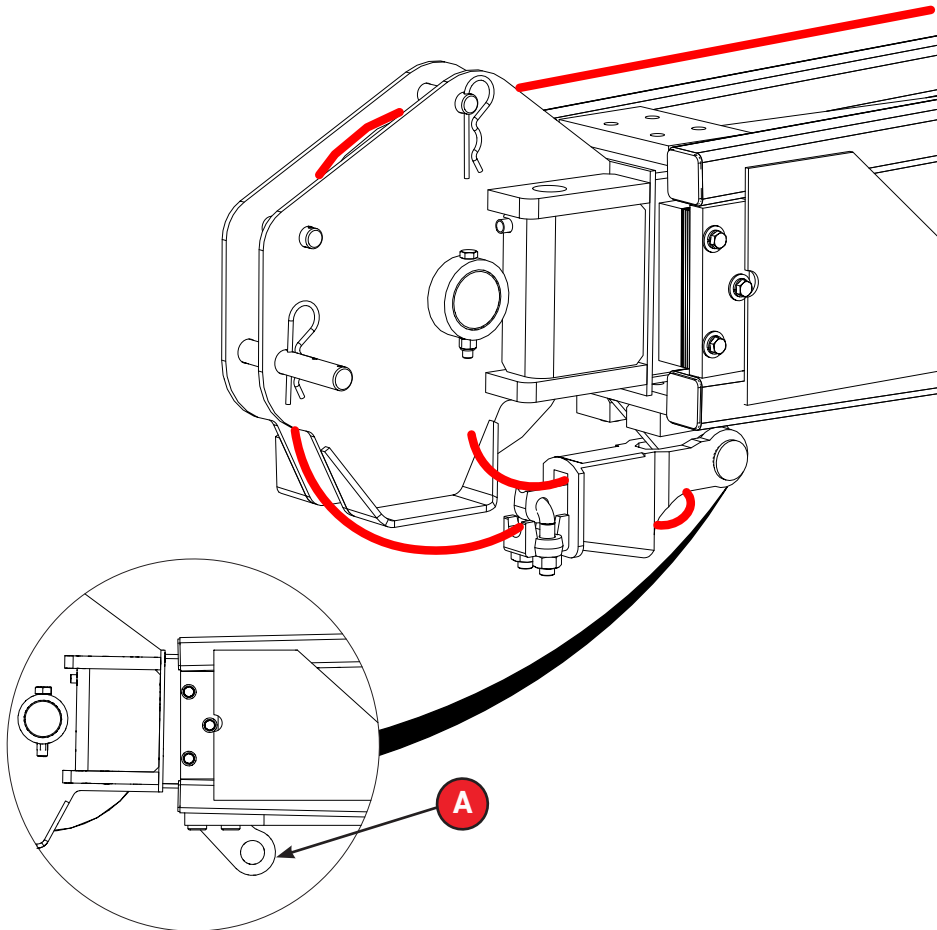

3. Slowly winch up until enough weight is taken off the jib to align the fourth (4th) pin hole with the fourth pin hole on in the left side of the boom head.



Raising the winch too high or too fast can cause damage to the lattice section.

### Removing the Winch Rope from the Fourth (4th) Pin Alignment

Detach the winch rope and winch rope beckett from the anchor point behind the lattice head sheave.

# 50-155 M & U

Jib Deployment and Stowage  
Changing the Offset of the Jib

## Changing the Offset of the Jib

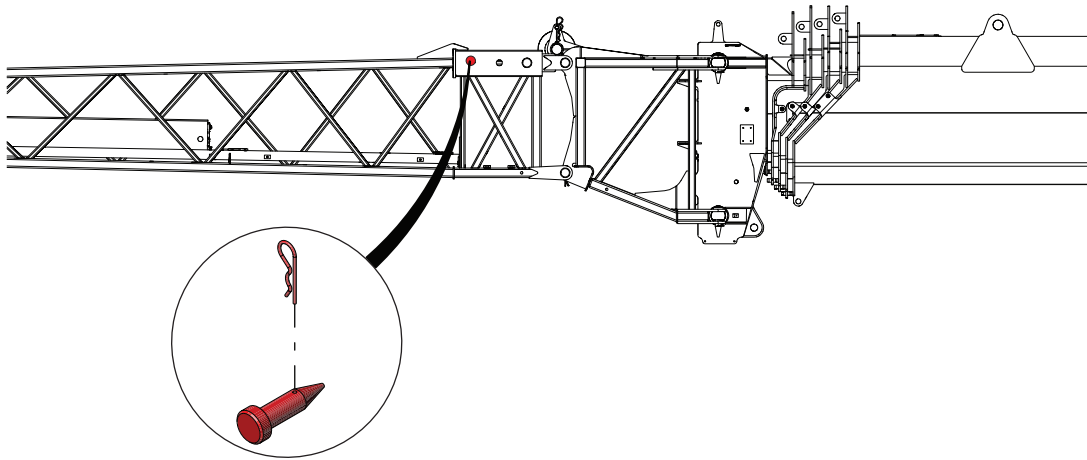

0 Degree Offset

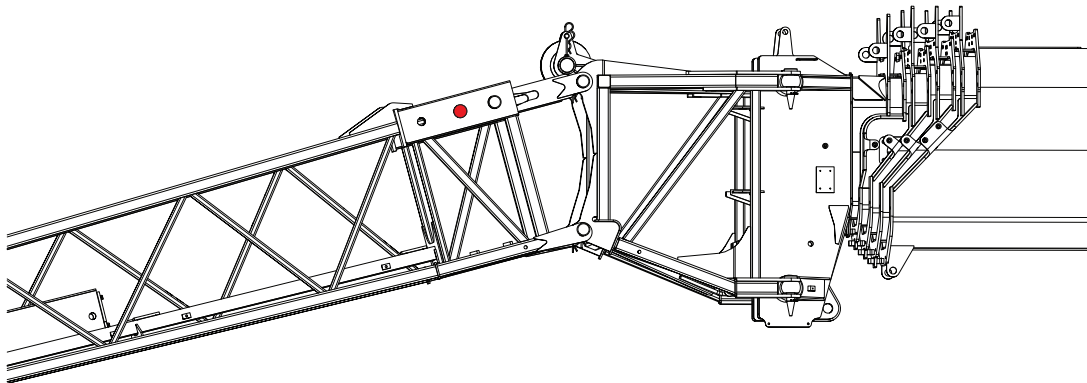

15 Degree Offset

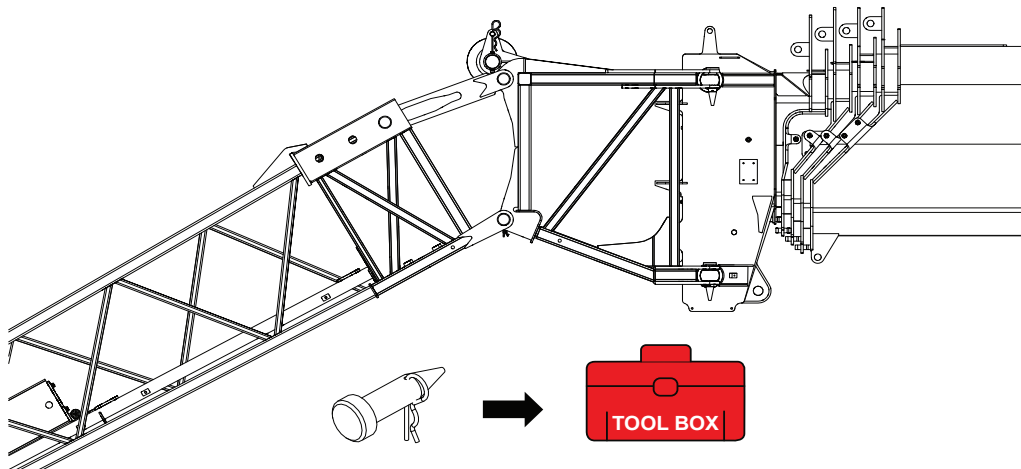

30 Degree Offset

## 50-155 M & U

### Jib Deployment and Stowage Changing the Offset of the Jib

1. Crane configuration should already be setup with fully extended outrigger position.
2. Lower the boom to the minimum boom angle.
3. Reeve the hoist line over the top center sheave on the lattice, around the jib sheave, and attach to the eye on the bottom of the jib tip.
4. Winch up to take the slack out of the hoist line and to take the weight off the jib offset pins.
5. Remove the jib offset pins from the 0 degrees offset hole and place in the 15 degrees offset hole or if Operator is using 30 degrees offset then place pins in the toolbox as shown in previous figure.
6. With the engine at idle, slowly winch down to pay out hoist cable while raising the boom angle. This will lower the tip of the jib until the jib comes in contact with the jib offset pins.
7. Remove the hoist line from the eye below tip of the jib and reeve the hoist line as needed.

Replace steps 3-6 with the following steps if using the feet provided on stinger head to increase the jib offset.

8. Extend the boom until the feet on the stinger head contact the ground and take the weight from the jib offset pins.
9. Remove the jib offset pins from the 0 degrees offset hole and place in the 15 degrees offset hole or if Operator is using 30 degrees offset then place pins in toolbox as shown in above figure.
10. With engine at idle, slowly raise the boom up until jib comes in contact with the jib offset pins.

## 50-155 M & U

Jib Deployment and Stowage  
Changing the Offset of the Jib



### Decreasing the Jib Offset

1. Crane configuration should already be setup with fully extended outrigger position.
2. Lower the boom to the minimum boom angle.
3. Reeve the hoist line over the top center sheave on the lattice, around the jib sheave, and attach to the eye on the bottom of the jib tip.
4. Winch up to take the slack out of the hoist line and to take the weight from the jib offset pins.
5. Replace the jib offset pins into the 0 degrees offset hole when the weight has been taken from the jib by the hoist line.
6. With the engine at idle, slowly winch down to pay out the hoist cable until the jib comes into contact with the 0 degrees jib offset pin.
7. Remove the hoist line from eye below tip of the jib and reeve the hoist line as needed.

Replace steps 3-6 with the following steps if using the feet provided on stinger head to decrease jib offset.

8. With the boom at 30 degrees, extend the boom to 60 ft boom length.
9. Lower the boom until the feet on the stinger head slightly contact the ground and take the weight from the jib offset pin.
10. Continue lowering the boom until the jib is horizontal, then replace the jib offset pins into the 0 or 15 degrees offset holes.
11. With the engine at idle, slowly raise the boom up until the jib comes in contact with the 0 degrees jib offset pins.



The jib must be at 0 degrees for stowage.

## 50-155 M & U

### Jib Deployment and Stowage Stowage

#### Stowage

To stow the jib, it is necessary to go through the steps to deploy the jib in the reverse order.

1. Crane configuration should already be setup with fully extended outrigger position.
2. Rotate the upper structure to the over-rear position.

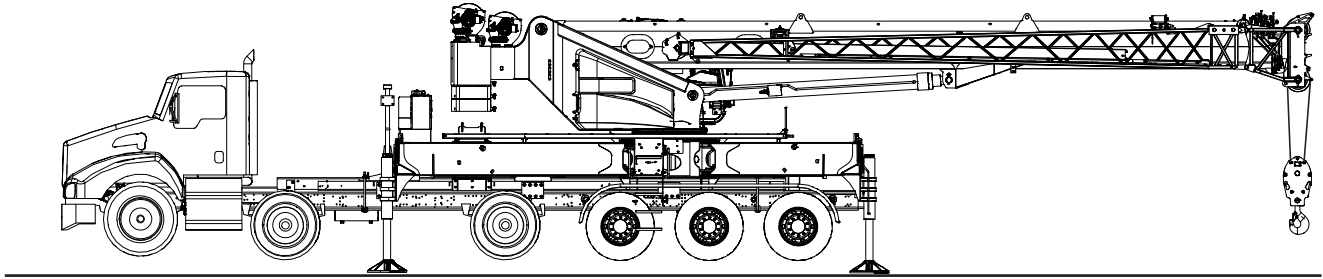

3. Retract the boom completely.

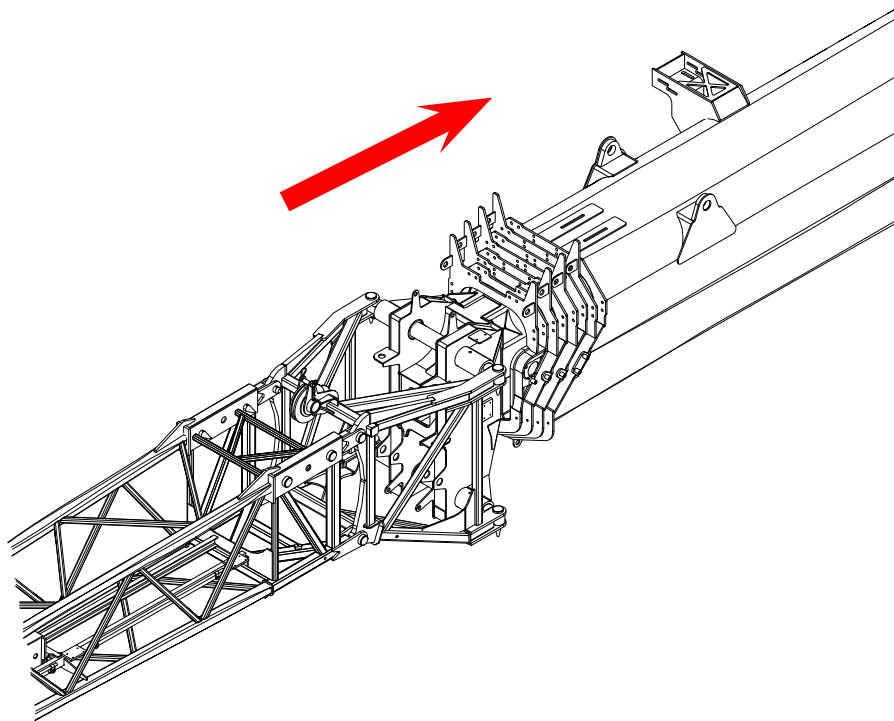

## 50-155 M & U

Jib Deployment and Stowage  
Stowage

4. Lower the boom to minimum boom angle to allow ease of removal of installation pins.

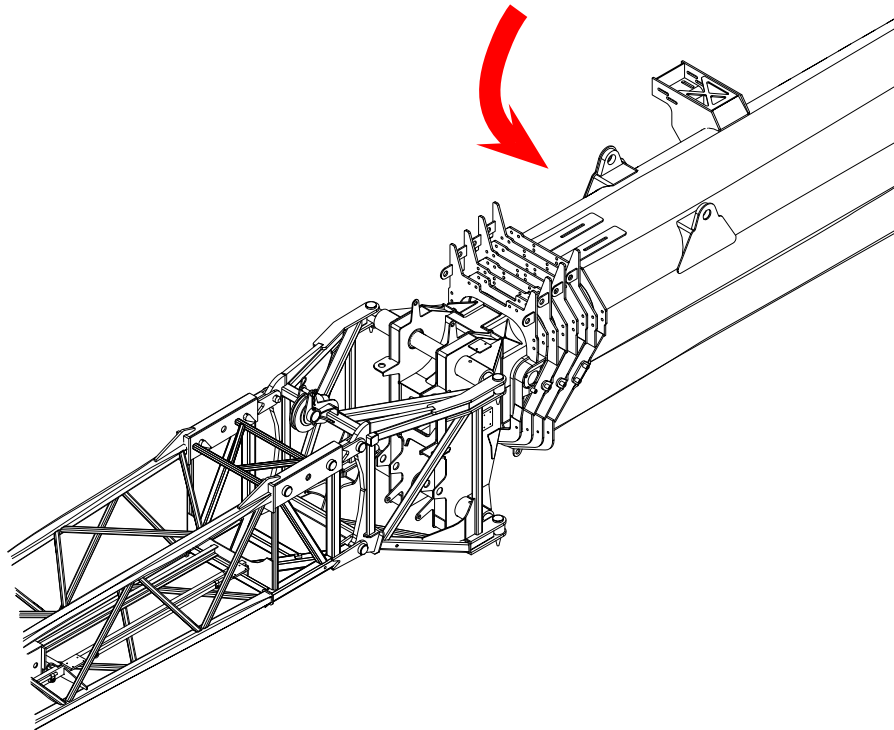

5. Disconnect the ATB plug (E) from the boom head ATB socket and connect it to the socket on the jib.

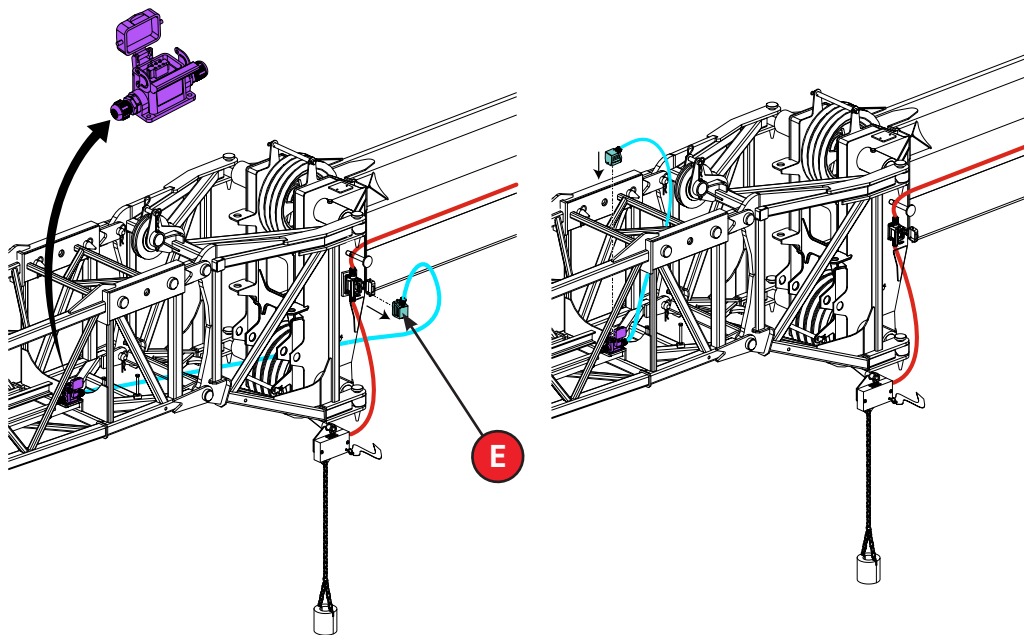

## 50-155 M & U

### Jib Deployment and Stowage

6. Move the plug from the Aux head socket (D) to the ATB socket on the boom head.

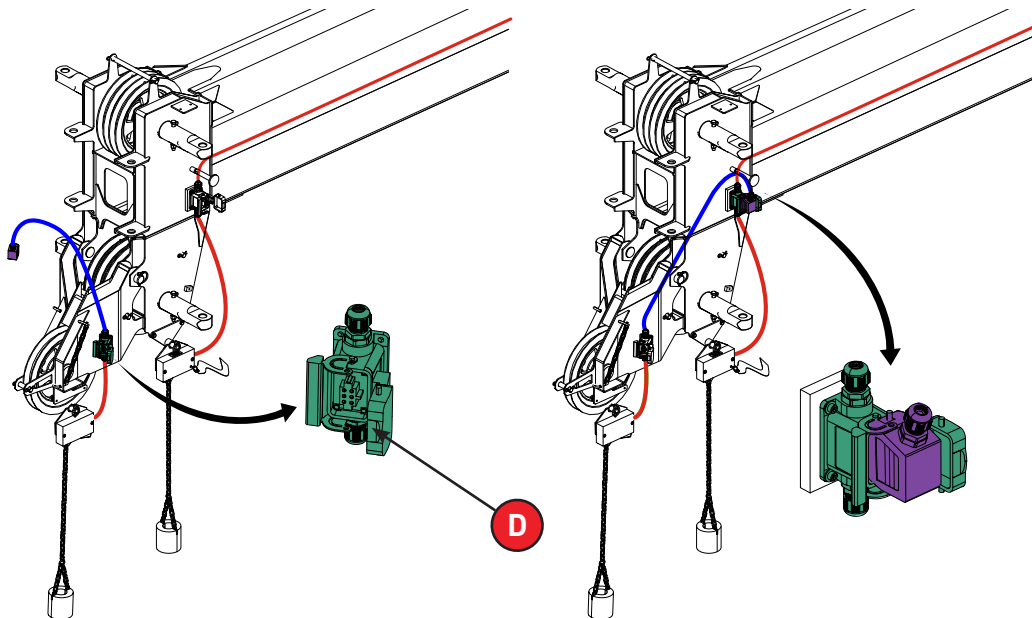

7. Remove the hoist line from the jib sheave and drape to the left side of the jib.
8. Attach a tag line to the eye (A) on the bottom tip of the jib.

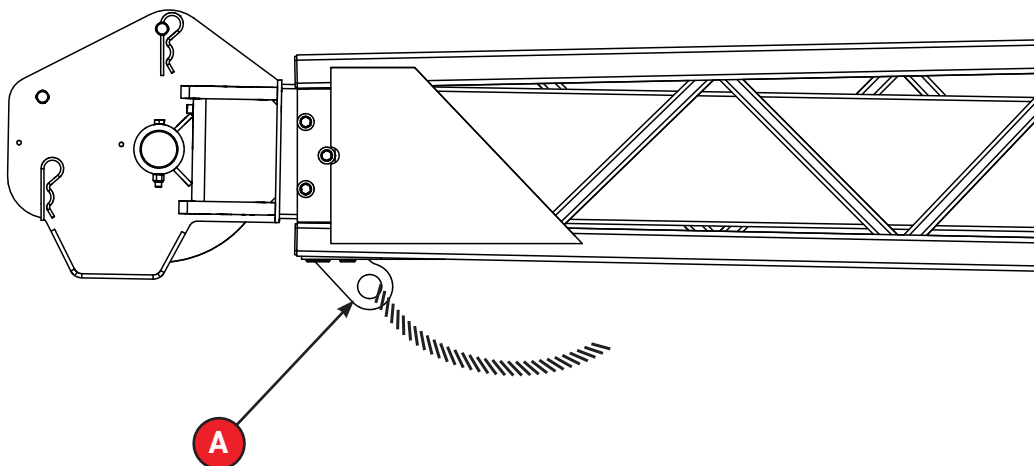

## 50-155 M & U

Jib Deployment and Stowage  
Stowage

9. Remove the left upper (4) and lower (3) jib mounting pins. Ensure the jib does not swing by controlling the tag line.

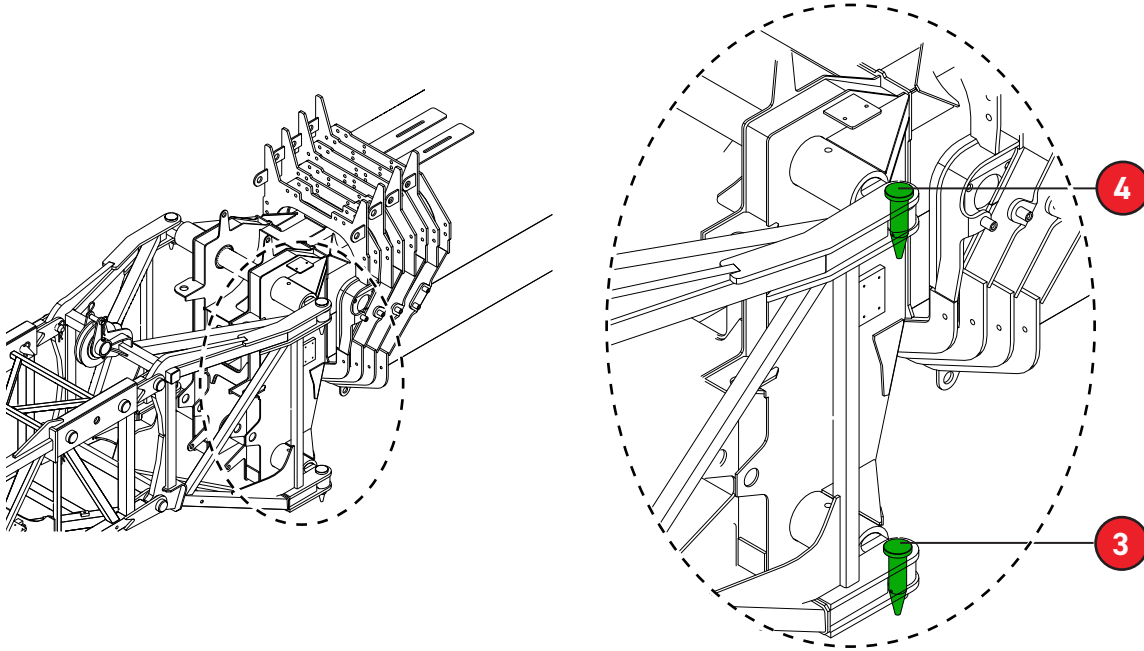

10. With the boom still fully retracted, slowly boom up to 30 degrees controlling the jib swing with the tag line.

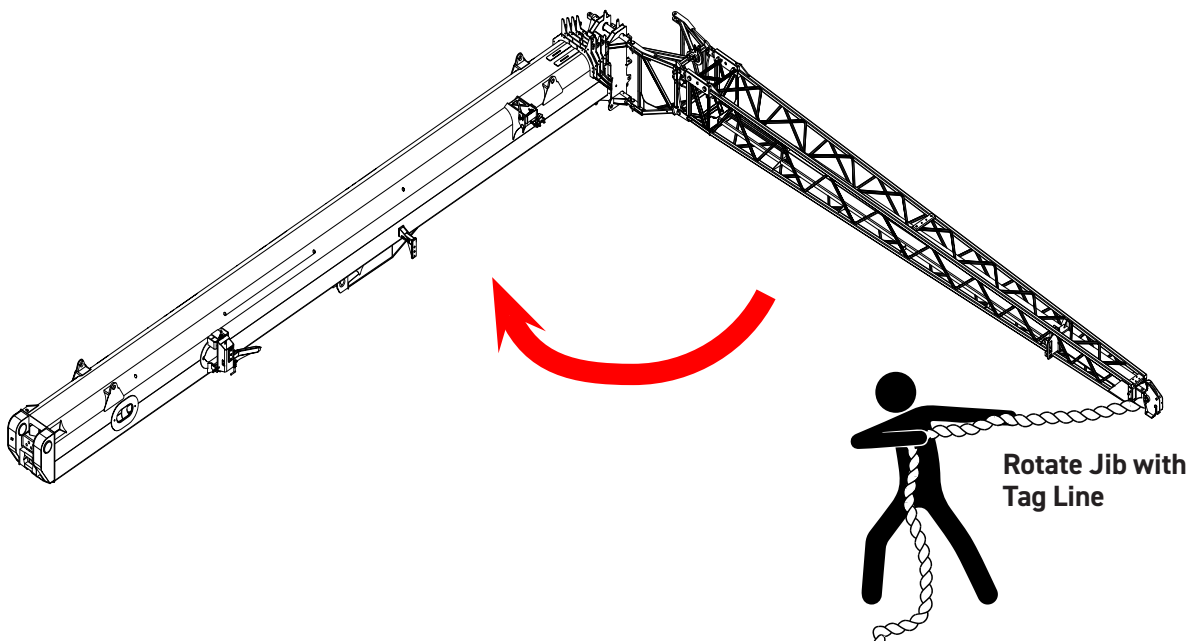

## 50-155 M & U

### Jib Deployment and Stowage Stowage

11. With the jib swung out approximately 15 degrees from the side of the boom and the boom at 30 degrees, slowly extend the boom 2-3 feet until the jib clears the stowage brackets.

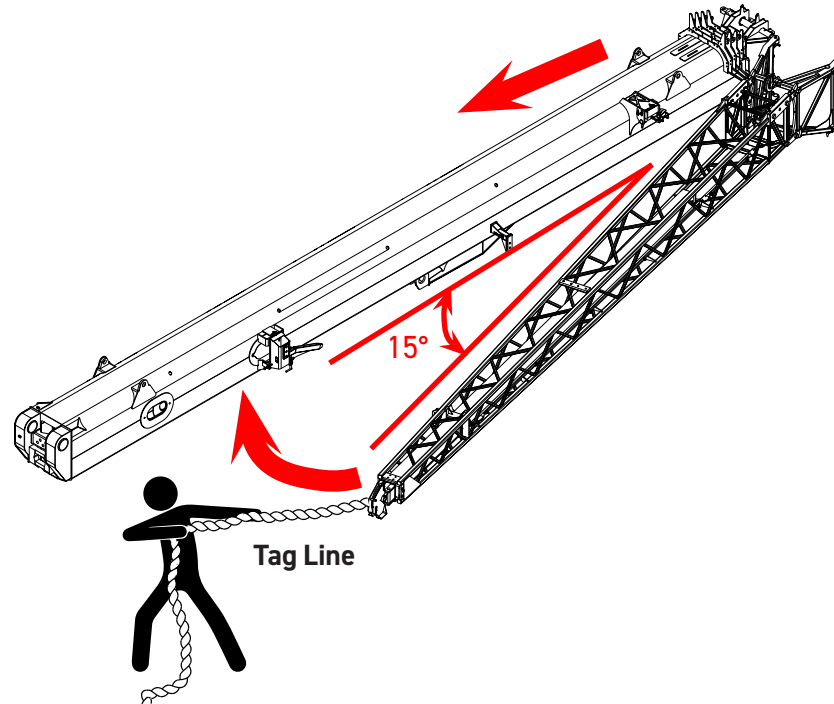

12. With the jib parallel to the boom retract the boom completely to engage the jib on the stowage brackets, ensuring the jib properly engages on the stowage brackets (G).

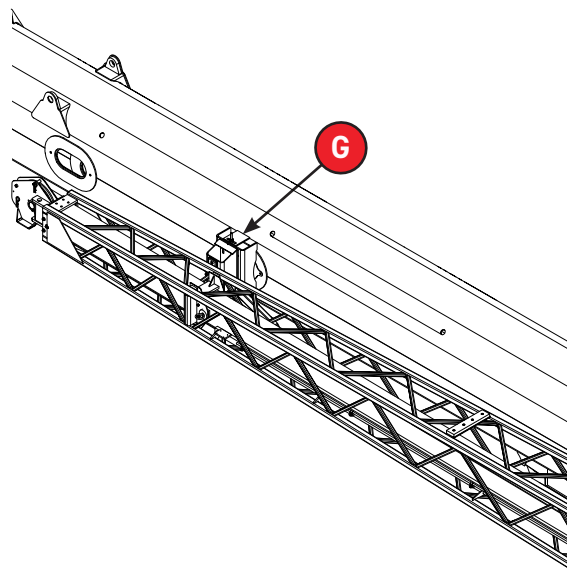

13. Lower the boom to horizontal to access T-handle.

# 50-155 M & U

Jib Deployment and Stowage  
Stowage



14. Push up and rotate the T-handle (C) to lock the jib into the stowage brackets.

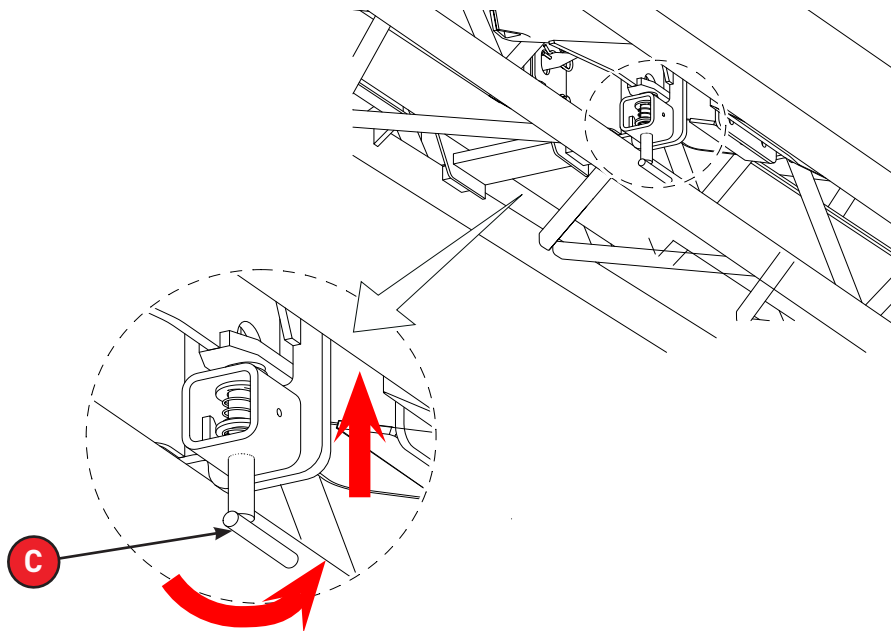

If improperly engaged or locked the jib may fall causing death or serious injury.

15. Remove the upper (1) and lower (2) jib mounting pins on the right side of the boom head.

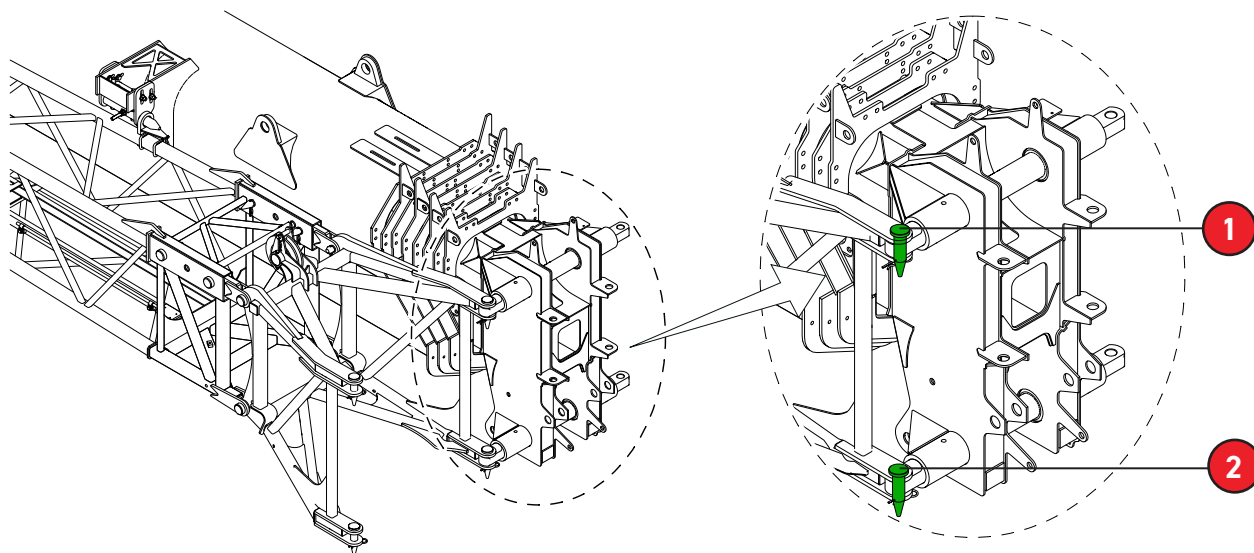

16. Remove the tag line.

## 50-155 M & U

Jib Deployment and Stowage

Jib Stow Assist Remote

### Jib Stow Assist Remote

1. Boom Swing Counterclockwise
2. Boom Swing Clockwise
3. Telescope Cylinder In
4. Telescope Cylinder Out
5. Boom Up
6. Winch Up
7. Boom Down
8. Winch Down
9. Horn
10. Winch Toggle
11. Emergency Stop

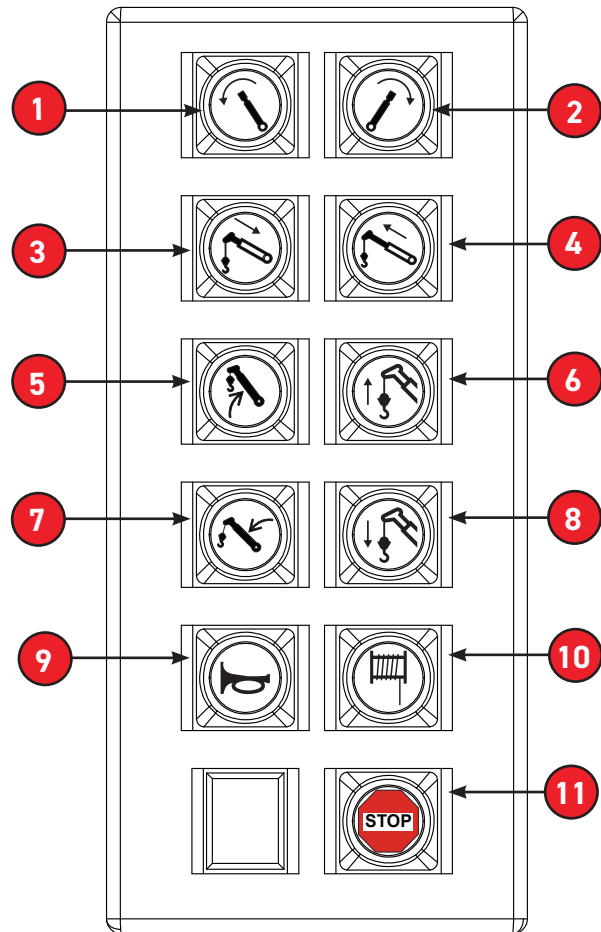

This remote will only function when the Remote Control Enable button is selected on the lifting control screen and crane seat arm rest is raised.

## Spooling Wire Rope on Drums

Care must be exercised when installing wire rope on the winch drum. Improper spooling can result in rope damage through crushing, kinking, doglegs, abrasion or cutting. Poorly installed wire rope will also adversely affect the operating characteristics of the machine by causing uneven application of force and motion. This can cause premature fatiguing and failure of the rope.

Thoroughly inspect and clean the winch before proceeding with the installation. Check the lagging and drum flanges for cracks, breaks, and excessive wear. Deformed or oversized drum and excessive undercutting at the base of the flange also indicate that repair or replacement of the drum is necessary.

Check the bearings for excessive wear and play. After correcting any defects revealed by the inspection and determining that the winch is in good operating condition, spool the wire rope as follows:

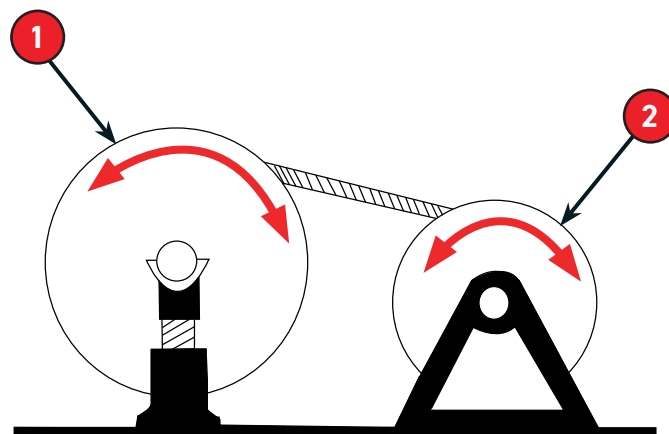

**Correct Spooling**

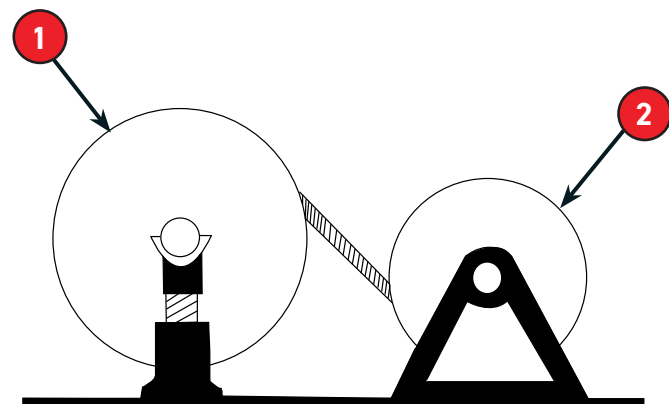

**Incorrect Spooling**

Mount the cable shipping reel (1) vertically on jacks or a suitable supporting structure, with a pipe or bar through the reel center. The cable should be drawn from the top of the reel as shown, in order to avoid reverse bending as it is spooled onto the drum (2).

If cable is wound from the storage reel onto the drum, the reel should be rotated in the same direction as the hoist.

## 50-155 M & U

### Jib Deployment and Stowage Spooling Wire Rope on Drums

Apply braking force to the reel flange in order to prevent overrun as the rope is being drawn off. Loops formed by overrun can cause kinks and doglegs in the rope, resulting in damage and premature rope failure. A timber or block forced against the shipping reel flange can be used to provide the required braking force.

Install the cable on the winch drum in accordance with the following procedure:

1. Position the cable over the boom tip sheave and route back to the winch drum.
2. Position the winch drum with the cable anchor slot on top.
3. Insert cable through the slot and position around the cable wedge.
4. Position the anchor wedge in the drum slot; pull firmly on the free end of the cable to secure the wedge.
5. Slowly rotate the drum, ensuring the first layer of cable is evenly wound on the drum.
6. Install the remainder of the cable, as applicable. The end of the cable should be even with the bottom of the anchor wedge, but not protrude beyond the drum surface.



If the wedge does not seat properly in the slot, carefully tap the top of the wedge with a mallet.

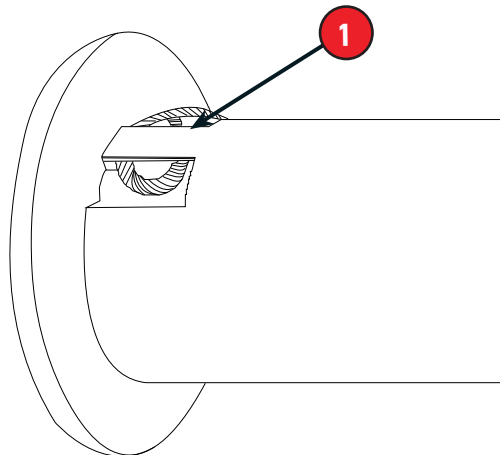

The wrong cable wedge could permit the wire rope to work loose and detach itself from the drum; possibly causing property damage or personal injury.

Tension the wire rope by braking the shipping reel and slowly operate the winch in the raise mode to wind the cable onto the winch drum. As the spooling proceeds, ensure the adjacent turns are tight against one another. A lead or brass hammer may be used to tap the rope over against preceding turns. Tight winding on the drum is absolutely essential.

## 50-155 M & U

Jib Deployment and Stowage  
Spooling Wire Rope on Drums



Never use a steel hammer or pry bar to move the rope over on the drum. These tools can easily damage the rope.

After the rope is wound onto the winch drum, reeve the cable as desired.



Use only factory supplied sockets, wedges, and pins of the proper size; make no substitutions.

Follow the procedure below when installing wedge type sockets on wire rope:



Make sure that the correct socket and wedge are used.

1. Lead the rope (3) through the socket (1), form a large loop and draw the rope end (2) back through the socket. A length of rope equal to 20 times the rope diameter should be drawn back through.

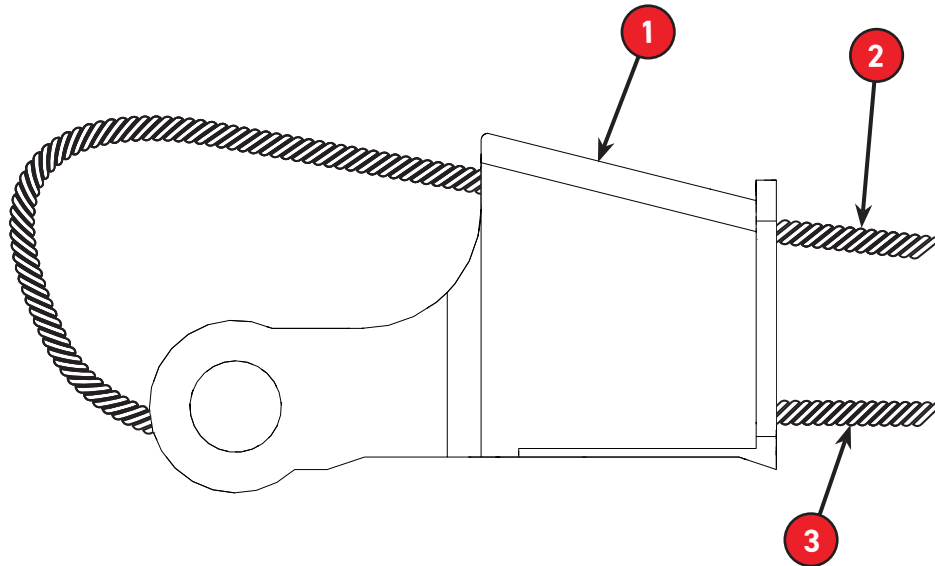

## 50-155 M & U

### Jib Deployment and Stowage Spooling Wire Rope on Drums

2. Insert the supplied terminator wedge (1) into the socket and allow the rope strands to adjust around it.

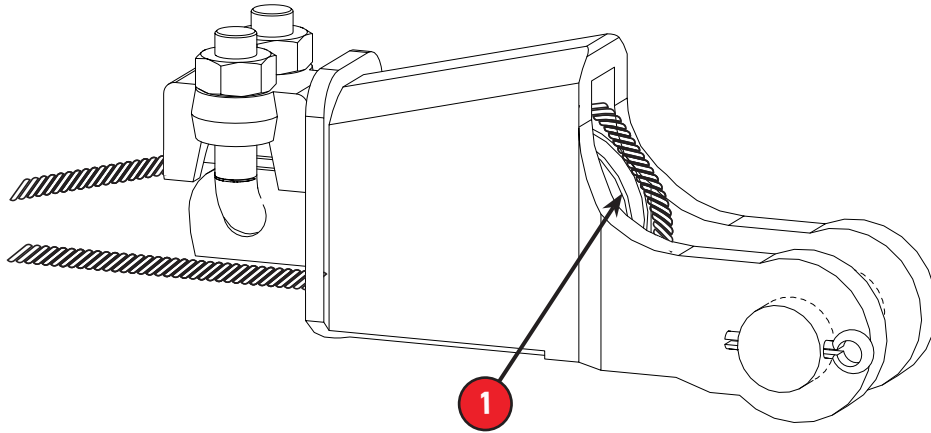

3. Seat the wedge and loop just tightly enough to allow handling by attaching the socket to a strong support and engaging the winch to take a strain on the rope.
4. Final seating of the wedge is accomplished by making lifts of gradually increasing loads. Avoid imposing shock loads on the rope until the wedge is firmly in place.

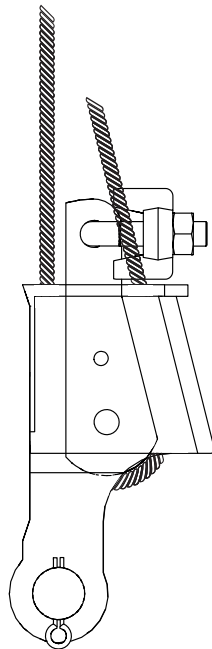

5. After the wedge has been firmly seated, install the U-bolt and saddle clamp as shown. Do not clamp the free end to the load supporting end as this will weaken the rope.

# 50-155 M & U

Jib Deployment and Stowage  
Hoist-Line Reeving

## Hoist-Line Reeving

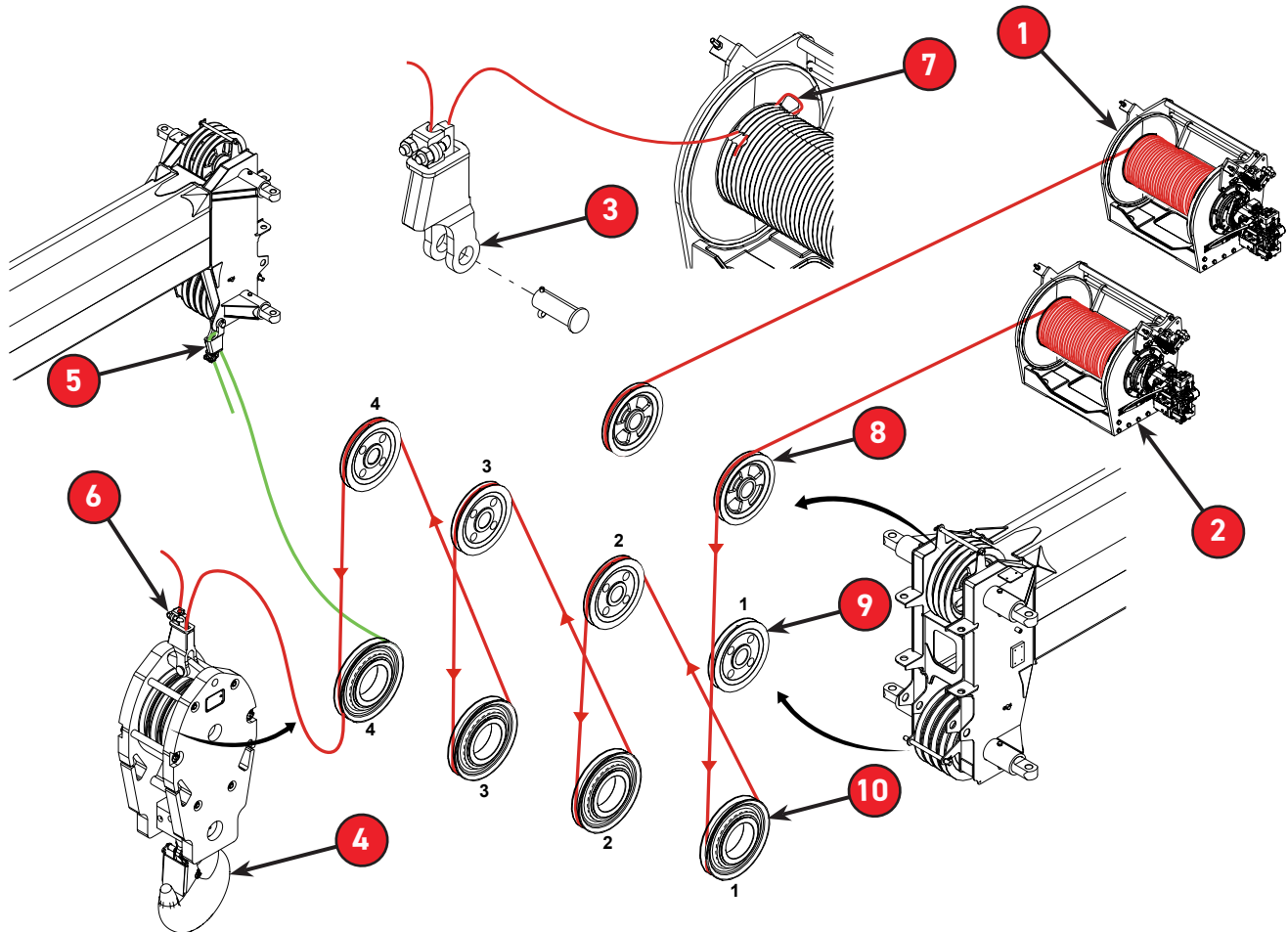

### Main Winch Reeving

1. Auxiliary Winch	6. Dead End for Odd Parts of Line
2. Main Winch	7. Winch Drum Socket - Wedge
3. Beckett Assembly	8. Boom Tip Sheave
4. Lift Hook	9. Lower Boom Tip Sheave
5. Dead End for Even Parts of Line	10. Load Block Sheave



Sheaves in the boom head and the hook block are numbered from left to right as viewed from the Operator's station. "D" indicates pinned end of rope.

## 50-155 M & U

Jib Deployment and Stowage  
Hoist-Line Reeving

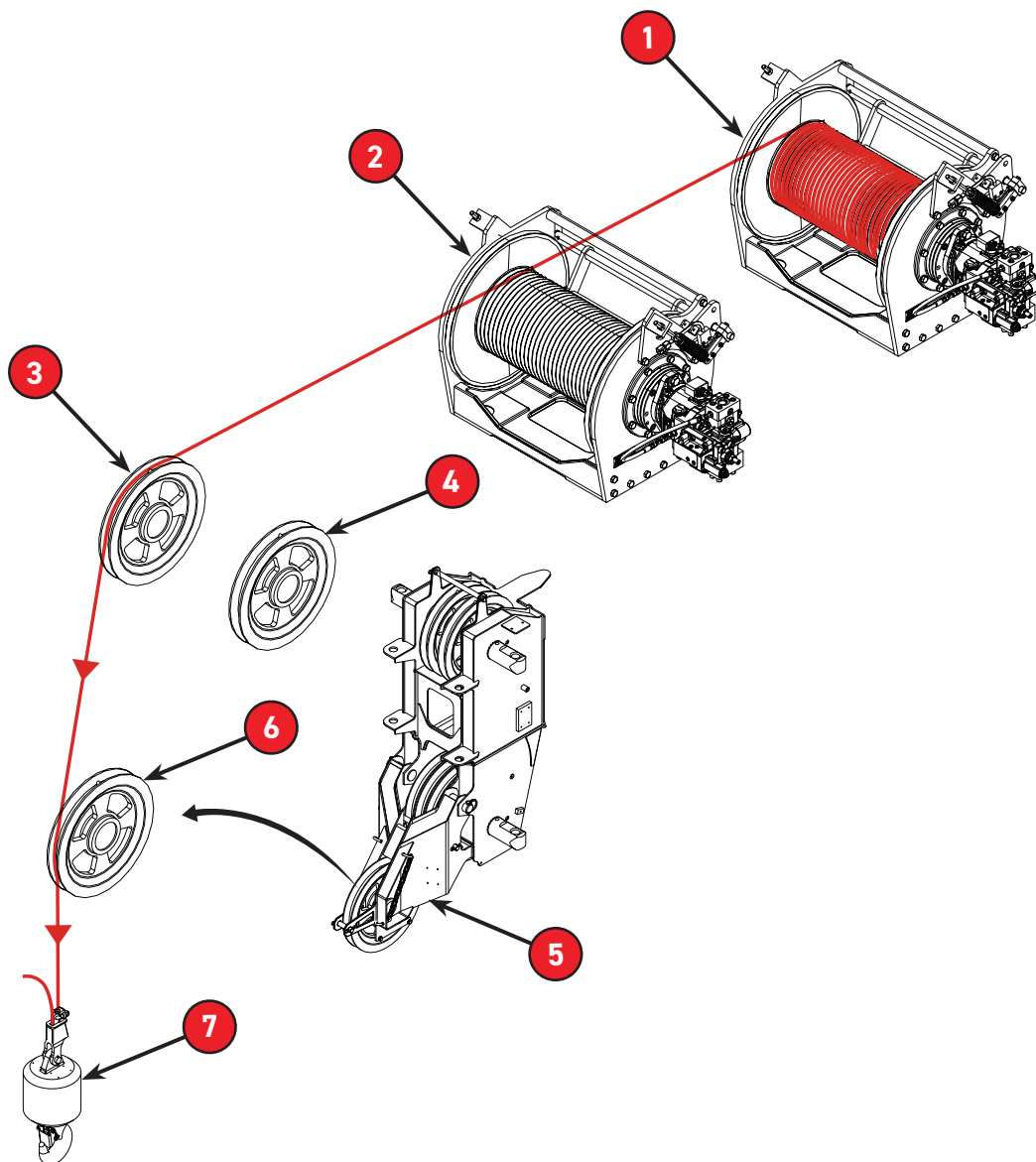

**Auxiliary Winch Reeving**

1. Auxiliary Winch	5. Auxiliary Head
2. Main Winch	6. Aux Head Sheave
3. Center Sheave - Boom Head	7. Overhaul Ball
4. Side Sheave - Boom Head	

## 50-155 M & U

Jib Deployment and Stowage  
Hoist-Line Reeving



Parts of Line	Boom Head (Load Sheave)	Hook Block (Block Sheave)
1	1	D
2	1 D	3
3	1 4	3 D
4	1 4 D	1 4
5	1 2 3	2 4 D
6	1 2 4 D	2 3 4
7	1 2 3 4	2 3 4 D
8	1 2 3 4 D	1 2 3 4

These patterns represent some, though not all, of the options for reeving patterns for hook blocks. Always use a reeving pattern that allows the block to hang level.

When reeving the crane in preparation for any job, it should be kept in mind that hoisting and lowering speeds decrease as the number of parts of line increases. For the most efficient use of the crane, it is therefore desirable to use the minimum required number of parts for lifting the load as determined by referring to the load rating chart.



Never use less than the number of parts called for by the load rating chart.

If it is not practical to alter the reeving during the course of the work, the required number of rope parts must be determined on the basis of the heaviest load to be lifted during operations.

When the required number of rope parts has been determined, reeve the rope as shown on the previous page. Attach a wedge type rope socket (refer to Wire Rope User's Manual) to the wire rope dead end and secure it to either the boom peak or hook block as required.

Dead end the rope on the hook block for an odd number of line parts, and on the boom peak for an even number of parts.



It may not be possible for the hook block to reach the ground if more than the minimum number of "parts of line" are used.

## 50-155 M & U

### Jib Deployment and Stowage Hoist-Line Reeving

Attach the Anti-Two-Block (ATB) weight to the ATB switch and to the first part of line as shown on the previous page. The ATB chain should be 36 inches long. Verify that the chain is not twisted or knotted after installation.

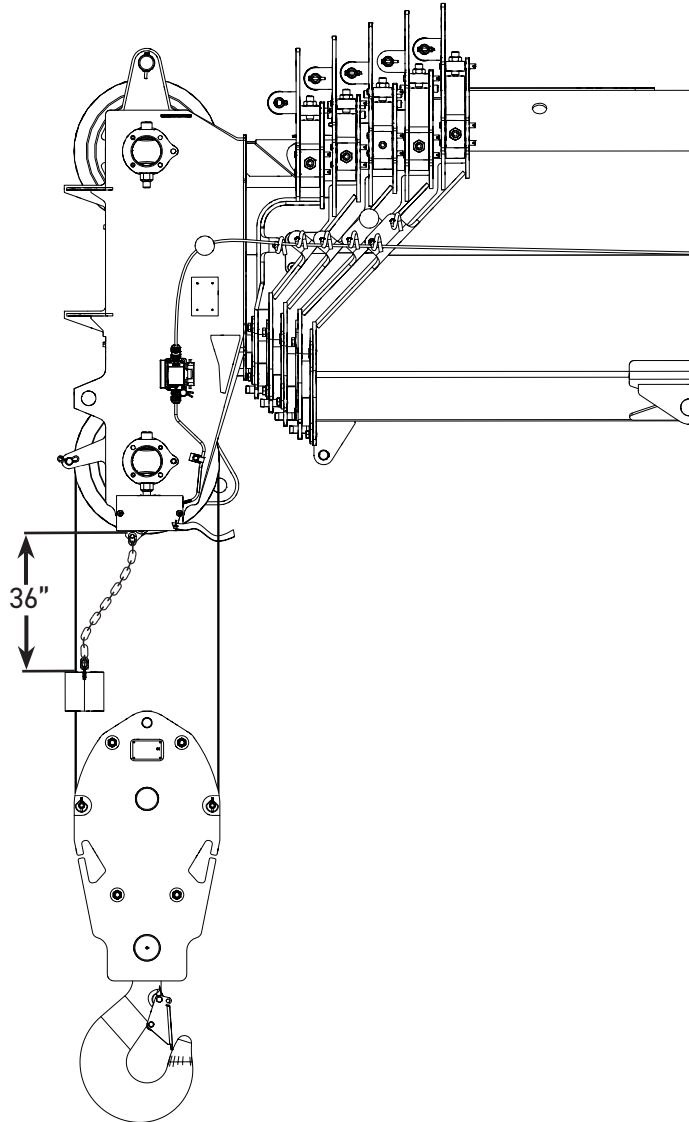

Test the ATB system by lifting the ATB weight. The light and audible alarms should be actuated in the cab and the boom down, boom extend, and winch up controls should disconnect.

As shipped from the factory, the crane has sufficient wire rope provided to allow the hook to reach ground level with any boom length and elevation when reeved with minimum parts of line required for the load being lifted. Refer to the Crane Capacity Chart for parts of line required.

## Cable Reeving

When reeving the machine for any job, remember that hoisting and lowering speeds decrease as the number of parts of line increases. For the most efficient use of the crane, it is desirable to use the minimum number of required parts for lifting the anticipated loads.



Never use less than the number of parts called for by the load rating chart. The minimum required number of parts is determined by referring to the load rating chart.

This machine incorporates a “Quick Reeving” boom head and block which do not require removal of the wedge and socket from the rope in order to change the reeving. Removal of two pins in the boom head and three in the hook block will allow the wedge and socket to pass through.



If a socket is changed or replaced, or if the hook block weights are changed, it is important to use the correct socket.

## Dead Ending Wire Rope in Socket

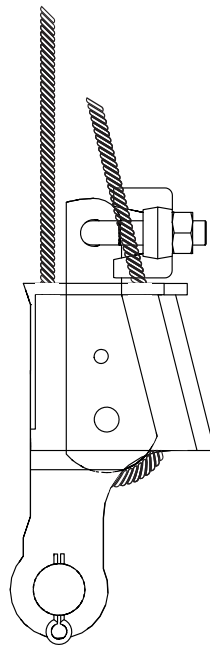

**Terminator Wedge Assembly**

## 50-155 M & U

Jib Deployment and Stowage  
Counterweight Installation

### Counterweight Installation

#### Installation from Frame Decking to Main Counterweight



The counterweight slabs are an integral part of this crane. When the crane is setup to travel at highway speeds, a number of these slabs may need to be moved to and carried on the counterweight supports of the deck of the crane in order to equalize the axle loads.

1. Lower the outrigger jacks to support the weight of the crane and level the crane.
2. Rotate the upper superstructure to a position straight over the rear of the crane. Use the slew reading to ensure that the upper superstructure is rotated to center rear (180 degrees).

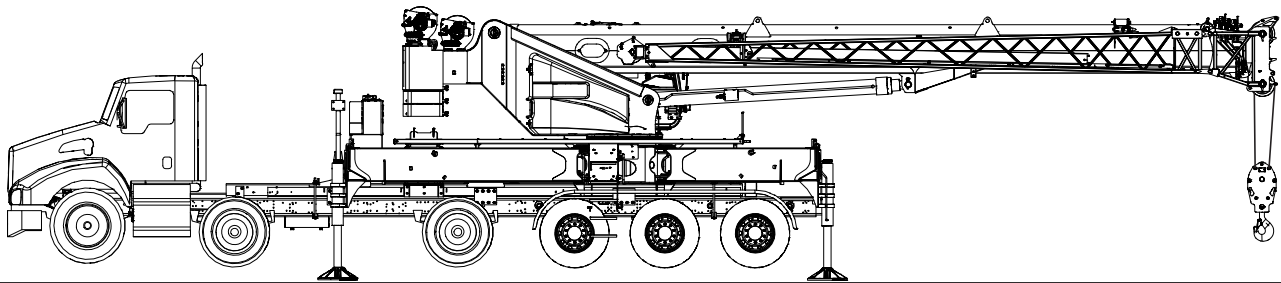

## 50-155 M & U

### Jib Deployment and Stowage Counterweight Installation

3. With the engine running, use the rocker switch (1) to raise or lower the rear of the counterweight cylinders to a position that is aligned with the counterweight.
4. Remove the horizontal pins (2) and the locking pins (3) into the cylinder rods connecting to the top slab.

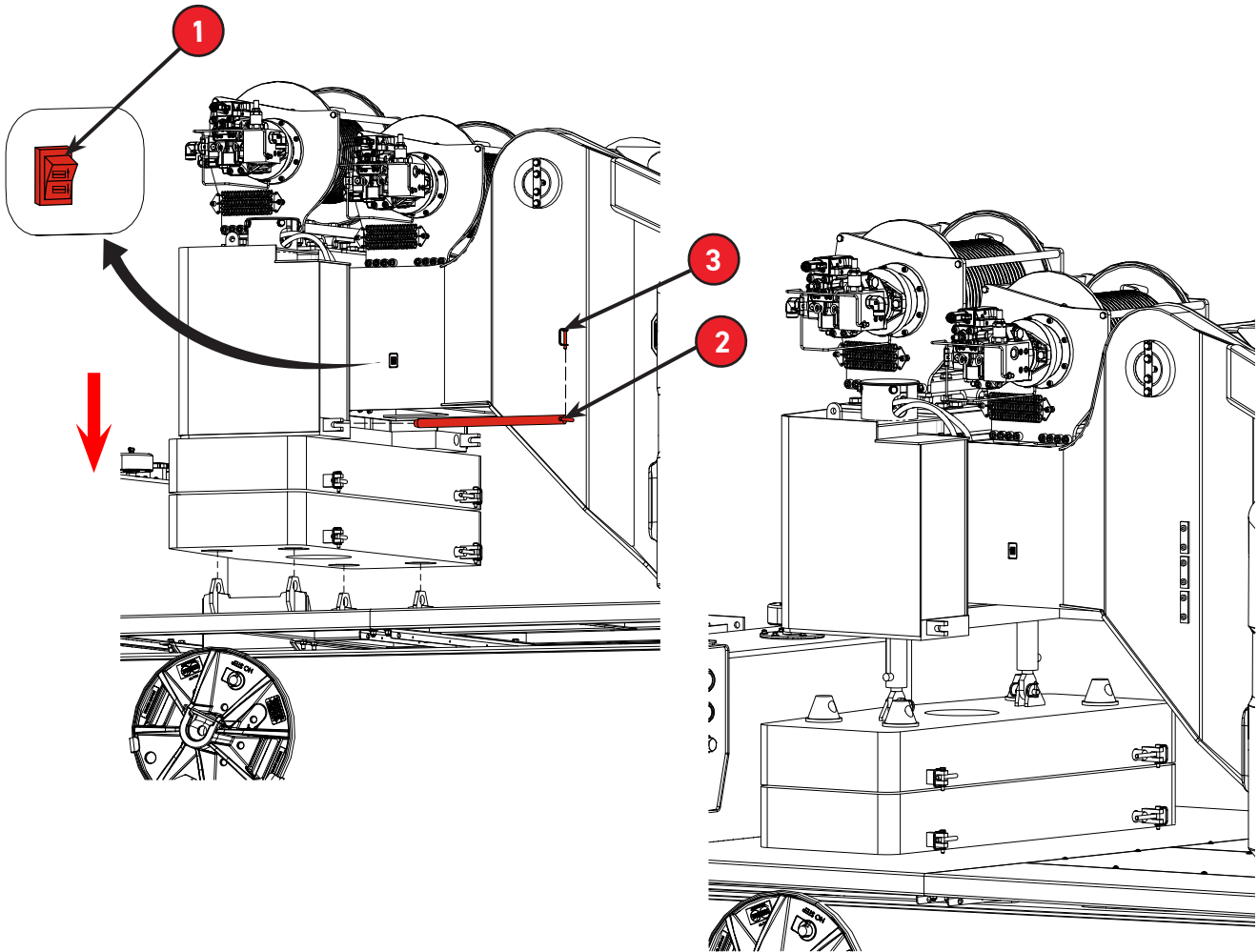

## 50-155 M & U

### Jib Deployment and Stowage Counterweight Installation

5. Remove the locking pins and horizontal pins from the lower-most slab to be attached to the counterweight cylinder stack.

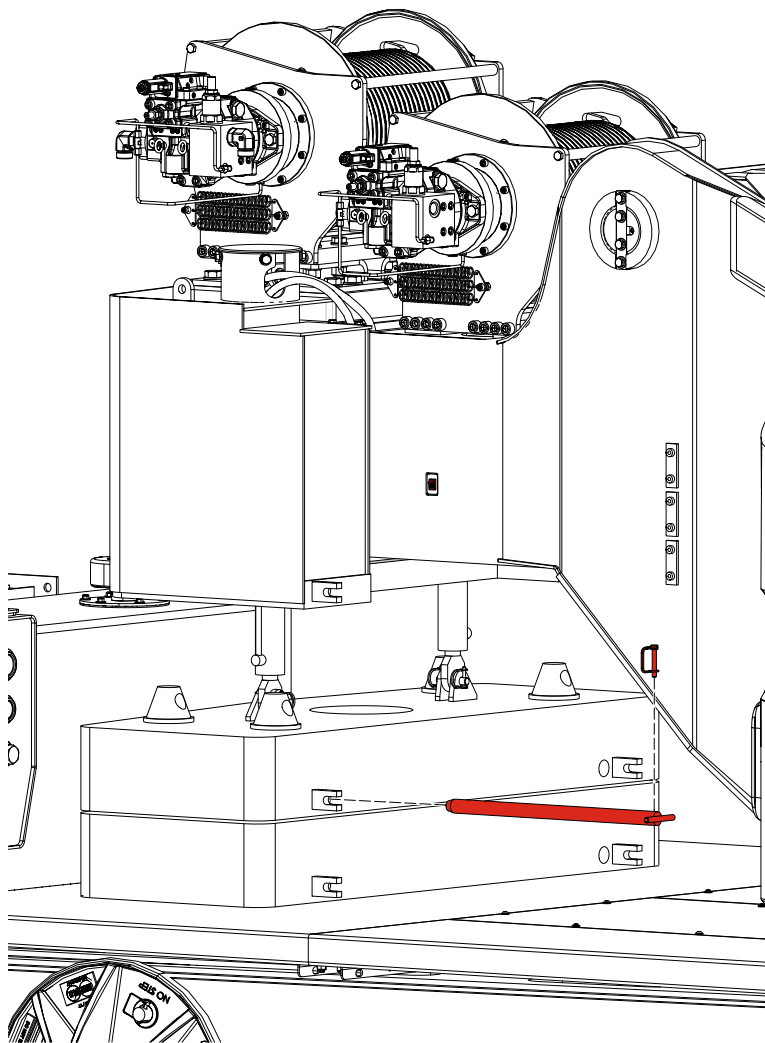

6. With the engine idling, slowly press the rocker switch to the **UP** position to raise the counterweight slabs tightly against the shell of the counterweight.

## 50-155 M & U

### Jib Deployment and Stowage Counterweight Installation

7. Install the horizontal pins (2) and locking pins (3) on each side to attach the stack to the counterweight.

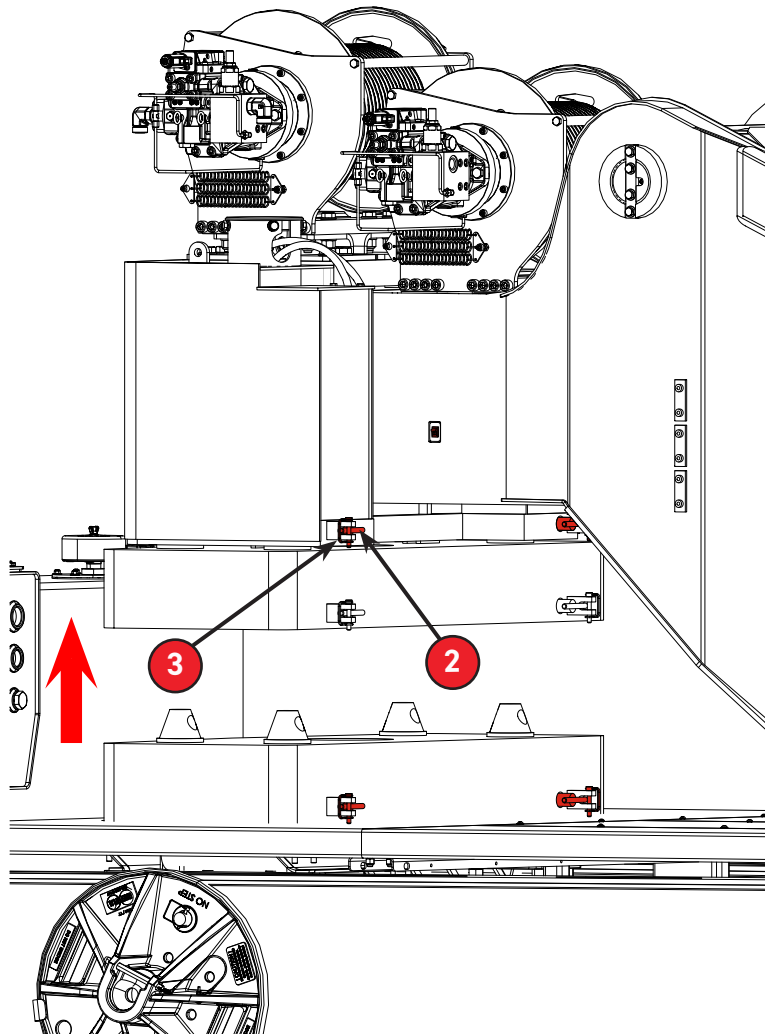

8. Press the rocker switch to the **DOWN** position to allow counterweight to be supported on pins, neutralizing the load on the cylinders.
9. Install pins in counterweight placed on deck so it remains secured during travel.

**PAGE INTENTIONALLY LEFT BLANK**

## Transportation

### Driving the Boom Truck

The 50-155 Boom Truck has on-road and limited off-road capabilities. Consider the terrain type, road conditions, and any hazards likely to be encountered en route before moving the Boom Truck around the work site or between sites. Plan the move in advance and carry it out safely.



The **Load King** Boom Truck is not a pick-and-carry crane. Never drive a truck with the boom extended, elevated, or with a load suspended from the load line hook.



Before moving the Boom Truck from a stationary position, always secure the boom in the boom rest and fully retract all the outriggers.

### On-Road Operation

When driving on highways, the Boom Truck is subject to the same regulations that govern the operation of other heavy equipment on public roads. Adequate lighting, flares, flags and safety equipment should be on the Boom Truck at all times.

### Off-Road Operation (Limited)

Good judgment in the selection of gear range and route of travel is essential when driving off the road. Holes and soft or spongy ground subject the Boom Truck to excessive stresses and should be avoided.

### Crane Height Awareness

Whether repositioning the Boom Truck at the work site or preparing for road travel, the Operator must always be aware of the crane's maximum road height. A placard is attached to the dashboard inside the truck cab, displaying the height of the crane as manufactured and installed. Failure to observe overhead obstructions while moving the Boom Truck can result in severe personal injury as well as damage to the crane and truck.



It is imperative for the Operator to know the crane's maximum road height and to be aware of all overhead obstructions. Failure to do so may result in severe damage to the crane/Boom Truck, death or serious injury to operating personnel.

### Situational Awareness

When moving around a job site, it is critical that the crane Operator is aware of what is going on with the crane as well as other vehicles and personnel. While moving a Boom Truck around a job site, the crane Operator should abide by the following guidelines as well as use common sense.

- Watch for overhead obstructions such as trees, power lines, or bridges.
- If the terrain is rough or uneven, it may be necessary to travel at a reduced speed to prevent instability or damage to the crane.
- The Operator must be careful on steep slopes to avoid tipping the crane.

## 50-155 M & U

### Transportation

#### Driving the Boom Truck

- Operating on steep grades requires caution because the oil in the engine or transmission will move to one side of the engine or transmission. As a result, the engine or transmission may not be fully lubricated, which could damage the engine or transmission.

#### Turning/Driving in Reverse

While operating a Boom Truck in reverse, the risk of accident or injury is greater and extra caution must be exercised.



Risk of accidents is increased when driving in reverse.

The following cautions must be observed at all times:

- When backing up, the driver must be aware of the needs of other traffic and their safety.
- If the driver does not have visual access to all the areas into which he will be traveling, a guide, who is in communication with the driver at all times, must be used who can see those areas the driver cannot.
- An audible back-up warning device does not replace the need for a guide.
- Be certain that no personnel or objects are behind the vehicle before moving.
- The rated maneuvering speed is the maximum speed allowed while driving in reverse.
- Follow all other regulations pertaining to driving on construction sites or on local streets.

#### Parking the Boom Truck



Use all appropriate procedures to secure a parked Boom Truck. An inadequately-secured vehicle can roll away and cause damage such as but not limited to injury to persons, death to persons, and damage to property.

The following conditions must be strictly adhered to by the crane Operator:

- A vehicle should never be parked on a slope greater than 18%.
- The parking brake should always be engaged when the crane is parked.
- The ground on which the crane is parked must be even and solid, with sufficient load-bearing capacity.

Under the following conditions, the Boom Truck must employ the use of the four (4) wheel chocks on the rear axle; where two (2) wheel chocks are on front side of rear tires and two (2) wheel chocks are on rear side of rear tires in addition to the parking brake engaged to prevent it from rolling away:

- The Boom Truck is parked on a slope.
- The Boom Truck is under repair or in need of repair, especially concerning any problems with the brake system.

#### Push-Starting the Boom Truck

The engine cannot be started by pushing or towing.

# 50-155 M & U

Transportation

Driving the Boom Truck with the Jib Deployed



## Driving the Boom Truck with the Jib Deployed

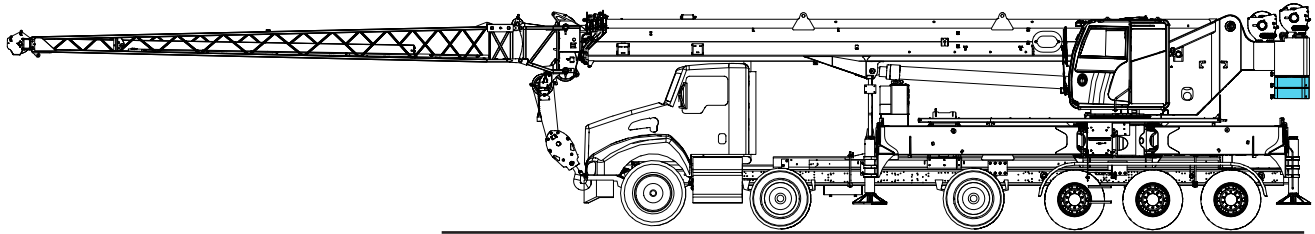

Travel Setup- Jib Deployed with Maximum Counterweight on Crane (Figure 1)

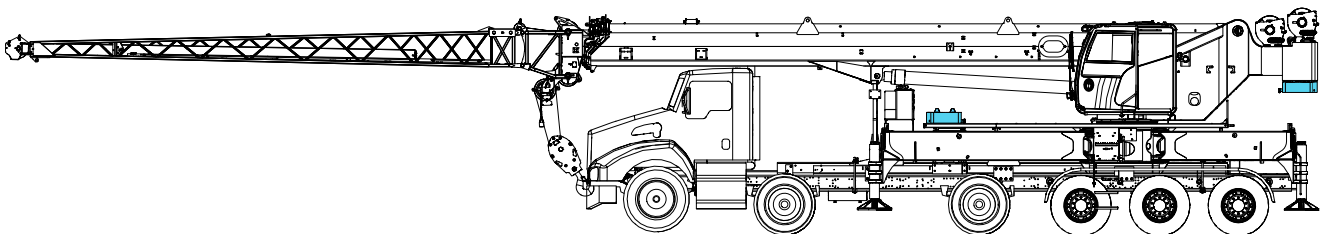

Travel Setup- Jib Deployed with Minimum Counterweight on Crane and Maximum Counterweight on Deck (Figure 2)

	<p>Be aware of the restrictions of moving the Boom Truck with the following crane setups. Failure to do so will result in front axle damage from overloading or structural damage to the crane from the dynamics of the jib in a deployed state. Exceeding maximum counterweight stored on the deck will cause interference with the lift cylinder when the boom is stowed into the boom rest.</p>
--	--

Setup	Counterweight Configurations	Jib Location	Boom Location	Swing Lock-OFF/ON	Traveling Yes/No	Speed Restriction
Setup #1	Full CWT on crane	Jib Deployed	Boom Retracted, Stowed in the Boom Rest	ON	YES	<2 MPH
Setup #2	<b>Min CWT on crane</b> 2750 <b>Max CWT on deck</b> 1 x 2750	Jib Deployed	Boom Retracted, Stowed in the Boom Rest	ON	YES	<2 MPH

# 50-155 M & U

Transportation  
Pre-Move Check List

## Pre-Move Check List

Before transporting the Boom Truck to and from job sites, perform the following safety checks:

1. Stow the boom in the boom rest.

	The boom must be stowed in the boom rest before driving the Boom Truck.
--	---

2. Lock the upper superstructure swing brake and engage the mechanical swing lock.



3. Secure the hook block or ball to the bumper loop. Use the ATB override switch to temporarily bypass the two block system disconnects.

	Failure to secure the hook block to the bumper ring before driving the Boom Truck will result in excessive swinging of the hook block and possible machine damage.
--	--

	Continuing to pull the block up after making contact may cause damage to the boom head and sheaves.
--	---

4. Ensure that all four (4) outriggers are completely swung inboard, the beams are retracted, and secured with lock rod (1).

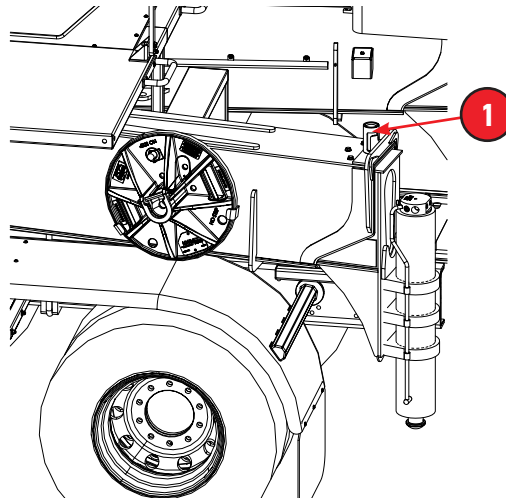

**Outrigger Beam Lock Pin** - Shown in the (locked) position, lift the bolt, rotate the pin clockwise until the bolt drops into the slot at the lowest position, which will prevent the beam from extending. Never drive a crane without locking all four outrigger beam lock pins (1).

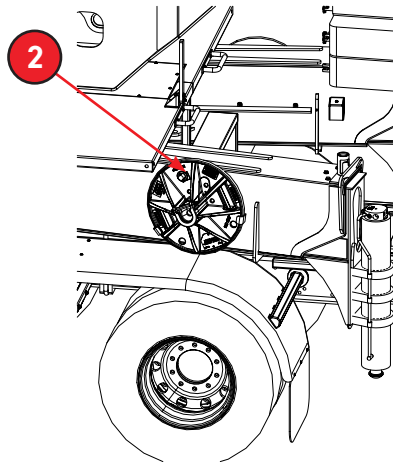

**Outrigger Pad Storage** - Insert the lock pin as shown above in the figure above(2) place on each pad and repeat this procedure on four (4) outrigger pads.

5. Check the tires for proper inflation pressure. Refer to the chassis manufacturer's specifications for tire sizes and pressures.
6. Adjust the seat and mirrors for clear visibility.
7. Disengage the main hydraulic pump drive. Never travel with the main hydraulic pumps engaged.
8. Check the counterweight slabs to ensure that they are properly secured for road operation and that the weight is balanced so that axles or tires are not overloaded.

**PAGE INTENTIONALLY LEFT BLANK**

## Inspection

### Pre-Start Inspection

The following items should be checked each day before start-up and the beginning of operations. Refer to Checklist and Inspection Form section, “[Daily Check](#)”.



Warning light illuminates on dashboard if diesel exhaust fluid or Urea level is low.

### Leakage

Check the ground beneath the machine for leaks. Refer to “[Maintenance and Service](#)” section.

### Lubrication

Perform the daily lubrication as required for cylinder mounting pins and bushings. Refer to the Maintenance and Service section “[Master Lubrication Chart](#)”.

### Lines and Blocks

Inspect the hoist lines, the hoist block and ball hook, and the crane attachment for readiness.

### Safety Equipment

Check the safety equipment, including but not limited to all lights, brakes, and hazard warning devices.

### General Condition

Inspect the machine for wear, leakage, and damage.

### Anti-Two-Block System

Inspect all ATB switches found on boom, jib, and auxiliary sheave heads for damage. Check the freedom of counterweight attached to the ATB switches and around the correct line of hoisting cable properly. Visually inspect all electrical connections, wires, and entire length of cable attached to the cable reel and connections, and ensure they are free from wear, damage and improper installation. Check the spring-loaded cable reel for proper tension and ensure that the reel is free to rotate. Verify proper operation of visual and audible warning devices by lifting each of the counter weights.

This crane is equipped with a disconnect system on the control linkages. Check this system prior to lifting loads. Hoist the hook block to the boom point so that there is contact between the block and the ATB counterweight. If all of the ATB functions are operating properly, winch hoisting will stop and the boom cannot be extended or lowered. If any of these functions continue, the disconnect system is functioning improperly and a complete system check is required. The boom raise, boom retract, and winch down functions remain active and will be unaffected by the ATB system.



If the disconnect system malfunctions while performing the ATB disconnect test, the hook block may be drawn into the boom head, resulting in damage to the crane.

## 50-155 M & U

Inspection  
Crane Boom

### Crane Boom

#### Main Boom Inspection and Maintenance Procedure

TASK	Inspection and Maintenance Procedure						ACTION
	DAILY	50 Hrs	250 Hrs	1000 Hrs	1500 Hrs	4 Yrs	
Broken wire rope or cut strands.							Replace Wire Rope
Corrosion of wire rope.							Replace Wire Rope
Wire rope kinking, crushing, un-stranding, bird caging, main strand displacement, or core protrusion.							Replace Wire Rope
Check the sheaves for wear.	X						
Check the pins for cracks.	X						
Lubricate the wire ropes.	X						
Clean the wire ropes.	X						
Lubricate the hook block.		X					
Lubricate the slides.			X				
Lubricate the main boom head.			X				
Lubricate the sliding surfaces.			X				
Check the sheaves roller bearings or bushings and are properly lubricated.				X			
Check the wear pads, shims and wear pad fasteners.					X		Replace as needed
Check chains for adequate lubrication.					X		
Check for corrosion of fasteners.					X		
Visually inspect extension and retraction ropes.						X	Disassemble Boom
Check chains for wear.						X	Disassemble Boom
Check the cable anchors for corrosion or cracking.						X	Disassemble Boom
Clean the boom sections and remove internal grease and re-grease with the specified lubricant.						X	Disassemble Boom
Check the sheave pins for corrosion and wear.						X	Disassemble Boom

## Structural Members and Welds



Although boom disassembly is recommended for a full inspection of components, a weekly visual inspection is essential to find indications of wear, corrosion, cracks, or breakage. If the crane is used in a highly corrosive environment due to salts and chemicals, then increase the inspection and maintenance frequency to twice weekly.

Visually inspect all structural members and welds including, but not limited to, the extended boom for straightness, roller (or pad) adjustment, and cracks. Pay special attention to the longitudinal welds joining the top, side, and bottom plates. Check the welds attaching the jib ears to the boom head and the welds attaching the boom head to the tip section. Inspect the cylinder attaching supports and the boom pivot area.

Inspect the superstructure welds, the welds on the hoist cylinder supports, and the welds between the bottom mounting plate and the vertical plates. This inspection is especially important if the machine is being used extensively in clamshell, concrete pouring, headache ball, or other high-duty cycle applications.

On the carrier, inspect the swing bearing weld band and supporting header welds. Check the welds attaching the outrigger box to the frame, outrigger box ends at the collar, jack cylinder mounting tube, and the beam welds.

Visually inspect all boom sections at least weekly or every fifty (50) hours, whichever occurs first. In preparation for the inspection, set the outriggers and rotate the upper structure of the crane to an area where the boom can be fully lowered and extended.

With the boom fully lowered and extended, visually inspect the sides, top, and bottom of each section for any unusual deformation, scrubbing, wear, or cracking in either the plates or welds, particularly the fillet welds along the bottom edge of the side plates of the telescoping sections. In addition, note any missing or illegible indicator mark decals on the telescoping sections.



If any cracks in either fillet welds or plates are noted, the affected component must be replaced before any further crane operations are performed. This is necessary to maintain the structural strength of the boom and prevent possible catastrophic failure resulting in injury or property damage.

Field repair of boom sections is NOT recommended because distortion may be introduced and the boom's original structural strength may be compromised.

Boom extension indicator decals are very important and should be in place at all times. Boom section failures can occur due to over-stressing within the rated capacity of the sections. If the sections are not equally extended, mark difference between the telescopic sections.



If any indicator decals are missing or illegible (either triangle markers or boom length numbers), order the applicable items through your distributor.

## 50-155 M & U

Inspection

Wire Rope Inspection

### Wire Rope Inspection

Safe operation of the **Load King** Boom Truck is dependent on the proper use of wire rope in all operations. The ideal situation is to remove a wire rope from service after receiving maximum service life, but without sacrificing safety. The end point of useful service life is determined by regular inspections of the wire rope by properly trained personnel.

OSHA and other agencies with jurisdiction issue instructions governing the inspection of wire rope used on special equipment and in specified industries. All wire rope users are urged to comply with the law for their particular situation. Inspections must be carried out at stated intervals. When the data obtained from these inspections indicates that the strength of the wire rope has appreciably decreased, and that further use would constitute a safety hazard, the rope must be removed from service. It is the responsibility of the user to know what codes apply to the particular situation and to comply with their requirements.

In the interest of safety, **Load King** believes that any wire rope, where failure might endanger personnel, equipment, or the load, must be removed from service when any of the listed conditions are detected. It is recommended to perform a daily visual inspection of the entire length of rope, and a thorough inspection at least once per month - including a full written report that is dated, signed, and kept on file. The following conditions for removal of a wire rope from service should be regarded as a guide, with any specific regulations covering your equipment and industry taking precedence.

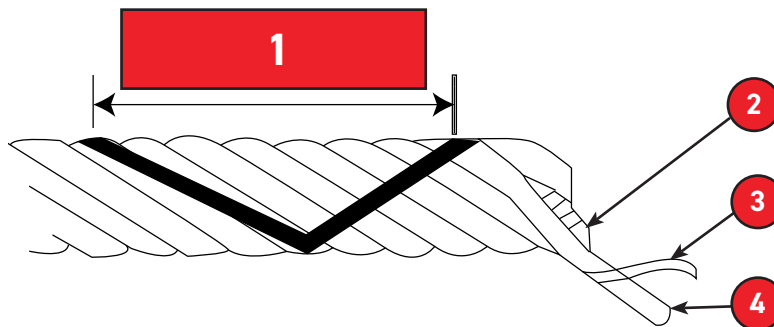

1. One Rope Lay Length
2. Core
3. One Wire
4. One Strand

1. Six broken wires in one rope lay, or three broken wires in one strand in one rope lay, is cause to remove the rope from service. One rope lay is the linear distance, measured along the rope, required by a strand to make one 360° turn around the axis as shown in the diagram above.
2. Wear of 1/3 of the original diameter of outside individual wires is cause to remove the rope from service.
3. Kinks, crushing, cuts, unstranding, or any other damage resulting in distortion of the rope structure are cause to remove the rope from service.
4. Heavy rusting, corrosion, pitting or any evidence of burning are cause to remove the rope from service.

5. Any reduction in rope diameters below nominal, for any reason, should be evaluated. The rope should be removed from the service if noticed reduction in diameter. Refer the table below:

1/32"	For rope diameters 3/8" through 1/2"
3/64"	For rope diameters 9/16" through 3/4"
1/16"	For rope diameters 7/8" through 1 1/8"

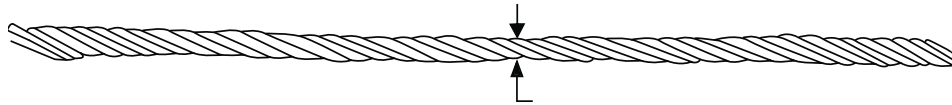

**Reduction of Wire Rope Diameter**

### Wire Rope Tension Check

Run the rope through a break-in process to seat the rope and provide the necessary pre-tensioning before performing the tension check. The steps for periodic re-tensioning are as follows:

1. Lift 2% - 3% MBF load and hold off of ground.
2. Cycle completely several times.
3. Lift 20% - 50% of minimum working load.
4. Cycle completely several times.

## 50-155 M & U

Inspection

Mobile Crane Load Test Inspection

### Mobile Crane Load Test Inspection

#### General

As a crane manufacturer, **Load King** does not recommend carrying out regular overload tests on mobile cranes. In some countries national laws require overload tests (e.g., in accordance with information from the crane manufacturer). However, an overload test after every change of location or crane reconfiguration is not a reliable and safe inspection method and can cause premature material fatigue.

Every mobile crane is subject to a load test by the manufacturer within a final acceptance procedure before delivery. Testing is conducted with loads in differing configurations in accordance with certain scenarios. These scenarios involve the lowest safety reserves, relative to the crane's mechanical strength and stability. This includes an overload test with defined conditions and standards which can be applied accordingly.

Further acceptance tests with overloads during the crane's working life must only be carried out after modifications or repairs of load-bearing components or after an extensive overhaul. In some countries, national regulations may require tests with overload and/or overload tests before carrying out hoist work after any change to the crane configuration.

The calculation of the load-bearing structure of mobile cranes satisfies all applicable international standards (EN, ISO, FEM, or FEM) and does not provide for continuous operation. Therefore, the crane has a service life which is defined by the permitted number of working cycles. Any overloading of the crane can have a negative effect and leads to a reduction in the crane's service life. This can become a critical problem if the crane is tested with overload before every hoist operation.

**Load King** strictly prohibits an Operator from overloading any crane. Safety equipment such as load limit devices prevent overloads being raised. The corresponding bridging/override switch is only provided for emergency situations or when the load limiter fails (as determined in the operating instructions).

#### Load and Overload Test

As the manufacturer, **Load King** does not recommend using the bridging/override switch regularly for overload tests and advises against regular overload tests. This includes avoiding tests in which the test load is attached via external equipment, without activating the bridging/override switch.



Regular or more frequent overload tests cause decrease in service life of the crane. **Load King** recommends avoiding regular overload tests.

The following aspects must also be taken into consideration from the viewpoint of the Operator:

- Operational planning, where the Operator may encounter:
  - o A higher floor elevation for loading than was planned
  - o Difficult handling of the additional test load
  - o A ban on executing any overload tests on-site in some fields of industry (e.g., petrochemical plants)

## 50-155 M & U

Inspection

Mobile Crane Load Test Inspection



- Operational safety, where the Operator must:
  - o Warn anyone in the vicinity that a test procedure is about to commence.
  - o Inform other personnel that they should leave the area during the test if possible.



Damage to load-bearing parts can cause an accident. After an overload test, conduct a thorough investigation to ensure the integrity of the load-bearing components.

Damage to load-bearing parts can occur due to cracks caused by overload and/or fatigue; such defects are not exposed by an overload test. For this reason, an overload test can give Owners and Operators a false sense of security.

To ensure the integrity of load-bearing components, **Load King** recommends a thorough investigation after an overload test, before carrying out hoist work. This investigation should consist a visual inspection along with function tests (including the safety equipment), and can necessitate non-destructive inspections such as magnetic particle or ultrasonic inspections.

Any malfunction or irregularity discovered during the inspection must be evaluated by a **Load King** service technician. This technician can determine whether the movement can be carried out safely or whether immediate repair/modification is required.

### Load King Recommendations Regarding Load Tests

#### Checking the Crane Assembly

Checking the crane assembly (e.g., after reconfiguration) should include:

- A visual inspection of all assembled parts on the ground before initiating any boom operation
- A function check of the crane with or without limited load, including:
  - o Any movements important for the job
  - o An inspection of all limit switches (among others, the hoist limit switches)
- An inspection to ensure the assembly has been carried out in accordance with the assembly instructions.

#### Load Test Factors

Load tests may be required by law after assembling the crane, or after changes in location. If such tests are required, do not exceed the permitted load of the crane beyond its capacity in the given configuration. This applies to all **Load King** mobile cranes for the static and dynamic load tests. A period of 5 minutes is sufficient for static tests.



The conditions listed above do not apply after reconfiguration or repairs to load-bearing crane parts. In this case, the load test factor can be higher (in accordance with the safety factors from the product standards). It is recommended to involve the crane manufacturer in such tests.

#### Load Test Configurations

If a load test is required by law, the test conditions must correspond with the conditions during the scheduled lift. It is acceptable to carry out a load test for a given crane configuration with reduced loads (below the maximum capacity), but at a greater radius, up to the maximum radius (maximum load moment).

**PAGE INTENTIONALLY LEFT BLANK**

## Maintenance and Service

### Introduction

Performing maintenance at regularly prescribed intervals is key to preserving the working longevity of a **Load King** Boom Truck (hereafter, referred to as “Boom Truck”). Some tasks must be done daily, and others must be done periodically throughout the weeks and months of the year. This preventive care is essential to ensure the equipment’s safe operation, performance, and maximized uptime.

The topics that follow organize the required checks and procedures by the intervals at which they should be completed. As per the maintenance inspection intervals.

The maintenance schedule helps accomplish the preventive maintenance requirements under average operating conditions. Average operating conditions such as high wear, loads, or strain on the crane may reduce the maintenance intervals. However, before altering the maintenance schedule, it is necessary to observe the Boom Truck’s operation and review the maintenance records. It is also necessary to consider all factors involved, and develop a revised schedule adequate to meet the routine maintenance requirements.



When conducting maintenance on the engine, always follow the engine manufacturer's guidance. The engine manufacturer's recommendations take precedence over those in this manual.

### General Service Information

Periodic maintenance, troubleshooting, and proper service and adjustment procedures are essential for machine productivity, longevity, and low-cost performance. Maintenance takes place at scheduled intervals, whereas service is when there is a specific problem to be addressed. This may be a slight distinction, but can be important.

It is the responsibility of the Operator to observe and report any unusual sounds, odors, or other signs of abnormal performance that could indicate trouble ahead. By detecting any malfunctions in their early stages, you can save yourself unnecessary downtime and your employer a lot of money! Therefore, it is also your responsibility to use good judgment in detecting potential problems in the early stages and repairing them quickly. If you don't, one problem may lead to another.

Before attempting to make a repair, ask the following questions:

1. Do you have the right tools?
2. Do you have the proper diagnostic equipment?
3. Can you accurately diagnose the cause of the malfunction?

If the answer to any of the questions above is “No,” then please call your **Load King** Service Representative.

If you decide to attempt a repair yourself, follow a logical troubleshooting procedure. Avoid replacing parts until the problem is identified. (Reference the [Troubleshooting Section](#)).

## 50-155 M & U

### Maintenance and Service

#### During Maintenance - Safety Practices

Once the cause of a problem or malfunction has been diagnosed, take the corrective action specified in this manual. Follow the procedures given for the specific problem. If the issue is not resolved, consult your distributor serviceman.



When performing maintenance or service on a vehicle, always place the shift lever in the neutral position. Engage the parking brake and place chocks on vehicle's wheels. Never work under, in front of, or behind a vehicle when the engine is running.

The methods used to remove assemblies, guards, or cab panels are left to the discretion of the customer, dependent on the type of overhaul equipment, and maintenance personnel at hand.

Keep parts in order when large components are disassembled, particularly when it has a great number of similar parts. Loosely reassemble assemblies whenever possible to prevent small parts from being lost. Keep subassembly parts together, but be careful not to get right and left-hand parts mixed up.

When an assembly is removed to correct a single difficulty, it is good practice to recondition the whole assembly at the time, thus avoiding repetition of work at a later date.

Bolts and nuts should be placed into their respective holes when removing guards, cases, or covers so that the proper bolt will be on hand when reassembling these parts.

### During Maintenance - Safety Practices

Caution and situational awareness apply not only when operating the Boom Truck, but also when conducting its maintenance. The following considerations should remain forefront while engaged in maintenance work.

1. Apply the parking brake before undertaking any maintenance task.
2. Lower all loads to the ground and ensure the load line is slack.
3. Move all controls to neutral position.
4. Disengage the Power Takeoff Unit (PTO).
5. Turn off the engine.
6. Use appropriate locks and tags to prevent accidental operation during service. (See [Lockout and Tagout Procedures](#)).



Do not insert hands or tools into any hole in boom sections while power is engaged or boom sections are moving.



Do not perform maintenance, adjustments, or repair procedures unless authorized to do so. Make sure all applicable instructions have been read and are understood thoroughly.

## During Maintenance - General Work Practices

The following points are effective work practices that make the job go smoother and provide for the best quality in the repair of the crane.

1. Before disconnecting wires, hoses or tubes, tag them for proper identification at reassembly.



When disconnecting hydraulic hoses. Release pressure on hydraulic systems before disconnecting hoses. Before releasing hydraulic pressure or disconnecting hoses, ensure that booms and cylinders are properly supported.

2. Before removing a component (pump, motor, valve, etc.), match mark its mounting position in relation to the adjacent component.
3. Before disassembling any multiple-section component (pump, motor, valve, etc.), mark the position of each section in relation with the other.
4. When removing shims, tie them together and identify the location from which they were removed.

## Operator Observation

It is the Operator's responsibility to observe and report any unusual sounds, odors, or other signs of abnormal performance that could indicate trouble ahead. On a routine basis the following items should be checked before starting or while operating the crane.

Visual Inspection - Check complete machine for any unusual condition.

Check for any leaks or damage to the hydraulic system.

Crane boom - Check the following:

- Hook block for wear or damage
- Two block system for proper function
- Cable and cable spooling on winch
- Cylinder pin connections for wear

Check PTO, drive lines, pumps, and pump mountings for wear or damage.

Check in the cab for:

- Instruments functioning properly
- Control operation
- Glass for good visibility
- Safety equipment is ready for use
- All lights work properly
- Cleanliness - free from mud and debris

## 50-155 M & U

### Maintenance and Service Storing Components

#### Storing Components

1. Store new components (valves, pumps, motors, cylinders, hoses, tubes, fittings) in a clean, dry, indoor location.
2. Do not unpack components or remove port plugs until the components are needed.
3. Once unpacked, carefully inspect each component for damage that may have occurred during shipping. Remove all shipping material from the ports of the components before installing them.
4. Fittings, hoses and tubes that are not equipped with shipping caps or plugs must be carefully cleaned before they are used. Flush the fittings, hoses and tubes with clean hydraulic oil then seal all openings until assembly.



Do not use rags to plug openings. Use clean plastic or metal plugs and caps.

#### Cleanliness

1. When removing a component from the crane, thoroughly clean the area around it to prevent dirt from entering the mating component or the hydraulic system. Cover all openings with plastic to prevent contaminants from entering the system.
2. Carefully clean the area around fittings before disconnecting hoses and tubes and the mating ports of all components to prevent contaminants from entering the system.
3. Use tools that are clean and in proper working condition.
4. Clean metal parts in nonflammable safety solvent. Clean rubber parts in warm soap and water. Lubricate all parts with clean oil at assembly, unless otherwise instructed.

## Maintenance Task Lists

### Maintenance Checks and Lubrication

The following are the recommended maintenance instructions for the **Load King** Boom Truck. The [Master Lubrication Chart](#) shows the proper lubricants to use and the frequency of lubrication.

### Daily Operator Checks

A regular schedule of maintenance is essential to keep unit at peak operating efficiency. Operator's that are responsible for the care of the unit should be familiar with the daily and weekly maintenance schedules and what to look for. Checking the following items at the recommended intervals will verify that the unit is safe and in proper operating condition.

### Checking the Truck

Proper operation of the crane is dependent on the condition of the truck, so the following checks should be done daily:

1. Set parking brake, start engine; then put the transmission in neutral and engage the PTO. Allow the hydraulic system to warm up slightly. Check for any sign of oil leaks or damaged hoses.
2. Extend all four outriggers to a firm surface, raise truck to just clear tires from ground, and shut the engine off. This is an opportunity to ensure that the outrigger holding cartridges are not leaking under load.
3. Check the lights for proper operation.
4. Check engine fluids. Maintain oil and water levels above the add mark.

Perform additional checks per truck Operator's manual.

### Daily Checks

Before daily operation begins, the crane should be run and checked for the following:

1. Set the parking brake, start the engine, put the transmission in neutral, and engage the PTO. Allow the hydraulic system to warm up slightly. Check for any sign of oil leaks or damaged hoses.
2. Extend all four outriggers to a firm surface, raise truck to just clear tires from ground, and shut the engine off. This is an opportunity to ensure that the outrigger holding cartridges are not leaking under load.
3. Check all controls for any signs of sticking and proper operation of functions. With the boom elevated and extended, shut off the engine and check for signs of boom drift.
4. Check to make certain that the load line is properly spooled on the winch drum and that it is not damaged.
5. Check all Operator aids for proper operation (ATB, Load Moment Indicator System, and holding valves).
6. Perform daily lubrication.
7. Check that the down haul weight (load block or ball) is properly secured to the load-line and the hook safety latch is in proper operating condition.

## 50-155 M & U

### Maintenance and Service

#### Maintenance Task Lists

### Weekly Checks

The following weekly checks should be performed in addition to the daily checks:

1. Check mechanical linkages for signs of wear or binding. Lubricate as necessary with according to the Master Lubrication Chart.
2. With all boom sections retracted, move the boom side-to-side to check for missing wear pads between boom sections, excess clearance, or looseness in the rotation gearbox. There should be no more than 2"-4" of play side-to-side at the boom tip.
3. If the machine is regularly in a salt-covered environment, wash the unit on a weekly basis to prevent rust and corrosion.
4. Perform weekly lubrication.

### Monthly Operational Checks

The following checks should be performed monthly in addition to the daily and weekly checks:

1. Check oil level in the rotation gearbox. It should be filled with HD-80W90 to the fill plug. At this time a shot of grease should be added to the grease zerk on the upper bearing. (Caution: Do not over grease this bearing!)
2. Check for excessive movement in the rotation gear mechanism. If over 4" of side-to-side movement is detected by moving the boom tip back and forth when fully retracted, it would be considered excessive.
3. Inspect all crane mounting bolts for signs of looseness or breakage. Replace or re-torque mounting bolts where necessary (See Torque Specs 1004909).
4. Extend all boom sections and check for physical defects, cracks and signs of over stress. Check the boom while extending to make sure it is properly sequencing. With the boom fully extended, check for excessive droop. Check to make certain all boom wear pads are in place and tight, and no excessive slop between boom sections is detected.
5. Check that all boom and outrigger pins are properly secured. Make certain that keepers and snap rings are present and properly installed.
6. Inspect load line for signs of kinking, crushing, cutting, or other damage.
7. Inspect weldments for signs of cracks at weld joints on all structural members.
8. Change hydraulic oil filter.

## 50-155 M & U

Maintenance and Service  
Maintenance Task Lists



### Quarterly Operational Checks

The following maintenance procedures should be done every 90 days (quarterly) in addition to the daily, weekly, and monthly checks:

1. Check and reset the rotation gear backlash.
2. Torque rotation gear mounting bolts. (See [Swing Bearing Bolting Procedure](#)).
3. Run the unit long enough to get the hydraulic system fully warmed up and inspect thoroughly for signs of leakage due to worn hoses or loose fittings. Correct as necessary.
4. Check the load block and the down-haul weight for signs of overloading, spread side plates, elongated holes, bent tie bolts or cracks.
5. Check for any deformation of the load block visibly showing apparent bend or twist from the plane of the unbent hook throat opening. Any distortion present should not cause an increase in the throat opening of 5% and not to exceed 1/4" (6mm).
6. Check all decals, placards, and load charts to ensure they are legible. If any placards are damaged or missing, they must be replaced.
7. Inspect all electrical wiring and Operator aids (ATB, Load Moment Indicator System, holding valves) for proper functioning and signs of deterioration.
8. Check the hydraulic tank breather filter for dirt and debris. If necessary, replace breather filter on the same schedule as changing the hydraulic oil and dual filters.

### Semi-Annual Maintenance Items

The following checks should be done semi-annually in addition to the daily, weekly, and monthly checks:

1. Torque the mainframe mounting bolts. (See Torque Specs 1004909).
2. Check hydraulic system pressures and adjust as necessary.
3. Inspect all visible wear pads for excessive wear or looseness.



All maintenance and inspection intervals are based on normal use. Excessively high duty cycle or dusty, dirty environments will require more frequent maintenance intervals. A unit that is subjected to particularly rough treatment, harsh environmental conditions, or is frequently overloaded, is subject to premature failure.

## 50-155 M & U

### Maintenance and Service Machine Maintenance Checklist

#### Machine Maintenance Checklist

##### Daily Check (8 Hours)

- |  |   |
|--|---|
| <input type="checkbox"/> Perform daily lubrication   | <input type="checkbox"/> Check wire rope and related components                                     |
| <input type="checkbox"/> Check hydraulic reservoir fluid level   | <input type="checkbox"/> Check controls   |
| <input type="checkbox"/> Check hydraulic cylinder mounting bushings and pins   | <input type="checkbox"/> Check instruments, gauges, lights, & safety equipment                      |
| <input type="checkbox"/> Check hydraulic components and hoses (see <a href="#">"Hydraulic Hoses"</a> topic in Maintenance and Service section) | <input type="checkbox"/> Make overall visual inspection   |
| <input type="checkbox"/> Check transmission oil level  | <input type="checkbox"/> Check ATB system   |
| <input type="checkbox"/> Check boom chains and ends  | <input type="checkbox"/> Check engine manufacturer's manual for additional maintenance requirements |
| <input type="checkbox"/> Drain fuel filters or water separator   | <input type="checkbox"/> Ensure swing brake is able to hold against full torque of swing motor      |
| <input type="checkbox"/> Check boom front slider pads  | <input type="checkbox"/> Drain water from air tanks   |
| <input type="checkbox"/> Drain air tanks   |   |

##### Weekly Check (40 Hours)

- |   |   |
|---|---|
| <input type="checkbox"/> Perform the daily check            | <input type="checkbox"/> Make thorough inspection of wire rope  |
| <input type="checkbox"/> Perform weekly lubrication         | <input type="checkbox"/> Visually inspect all structural members and welds for cracks, alignment and wear |
| <input type="checkbox"/> Check swing reducer oil level      | <input type="checkbox"/> Check boom for wear, cracked welds, alignment and missing or illegible decals    |
| <input type="checkbox"/> Check air system safety valve      | <input type="checkbox"/> Check engine manufacturer's manual for additional maintenance requirements       |
| <input type="checkbox"/> Check hydraulic cylinders and rods | <input type="checkbox"/> Clean machine weekly if salt covered to prevent rust and corrosion               |

## 50-155 M & U

Maintenance and Service  
Machine Maintenance Checklist



### Monthly Check (100 - 200 Hours)

- Perform daily and weekly checks
- Perform monthly lubrication
- Check hydraulic reservoir for moisture
- Check all slider pads
- Have hydraulic oil sample analyzed
- Check engine manufacturer's manual for additional maintenance requirements

### Quarterly Check (250 Hours)

- Perform daily, weekly and monthly checks
- Perform quarterly lubrication
- Change hydraulic return line filters
- Check engine manufacturer's manual for additional maintenance requirements
- Lubricate valve disconnects
- Clean and wax all exterior painted surfaces

### Semi-annual Check (1000 Hours)

- Perform daily, weekly, monthly and quarterly checks
- Perform semiannual lubrication
- Check hydraulic reservoir relief valve
- Clean hydraulic reservoir intake suction filter
- Check air dryer desiccant for signs of oil accumulation
- Check hydraulic relief valve pressure settings
- Torque swing bearing bolts to the proper specification and according to tightening sequence
- Check engine manufacturer's manual for additional maintenance requirements
- Check all adjustments specified in the "Maintenance and Service" section of this manual and any vendor manuals supplied

### Annual Check (1500 - 2000 Hours)

- Perform daily, weekly, monthly, quarterly and semiannual checks
- Perform annual lubrication
- Disassemble winch and inspect
- Drain and clean hydraulic reservoir
- Change hydraulic fluid (unless checked by oil analysis).
- Drain and refill the winch lubricant
- Check hydraulic hoses (see "Hydraulic Hoses" topic in Maintenance and Service section)

## 50-155 M & U

Maintenance and Service  
Hydraulics System

### Hydraulics System

#### Precautions During Maintenance

Do not check for hydraulic leaks with hands, fingers, or skin. Hydraulic fluid under pressure can penetrate skin up to 4" away from a pinhole leak.

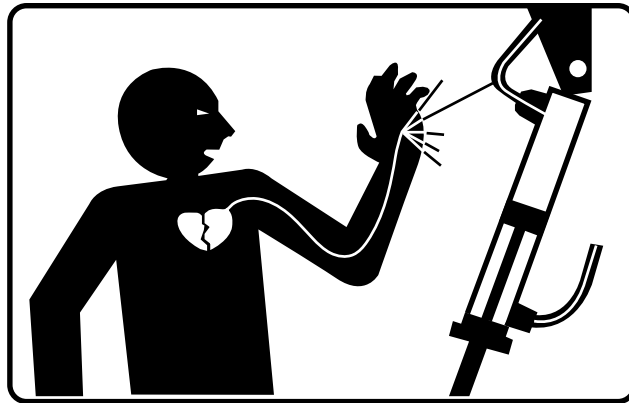

Hydraulic fluid injection may result in, but is not limited to, the following conditions:

- Blood poisoning
- Bacterial infection
- Permanent damage to blood vessels, tendons, and nerves
- Compartment syndrome
- Necrotic tissue
- Amputation
- Death



If anyone has skin contact with pressurized hydraulic fluid, seek immediate medical attention. Problems may not be instantly apparent, and may worsen with time. Surgery is often needed to remove dead tissue and to remove internalized hydraulic fluid.



Oil under pressure easily penetrates human skin and can cause serious injury or death. Oil under pressure can be nearly invisible. Check for hydraulic leaks with a piece of cardboard or wood.

Do not open lines to bleed air from cylinders.



Do not perform hydraulic inspections while the system is under pressure or a load is raised. Do not loosen or tighten hydraulic lines under pressure. Lower the load or relieve hydraulic pressure before loosening any hydraulic fittings.



Hydraulic oil is flammable. Do not check inside a hydraulic tank with an open flame. Keep open flame away from hydraulic systems. Do not weld near hydraulic lines and components without placing a protective cover over the hydraulic system components.

## 50-155 M & U

Maintenance and Service  
Hydraulics System

Oil is a regulated hazardous waste. Do not spill or dump oil. Capture oil when repairing or draining systems. Oil disposal must conform to State and Federal regulations. Do not overfill hazardous waste containers or reservoirs.



Do not alter specified flow and pressure settings. Higher than specified flows and pressures can cause damage to crane and hydraulic components. Lower than specified flows and pressures can result in loss of power.

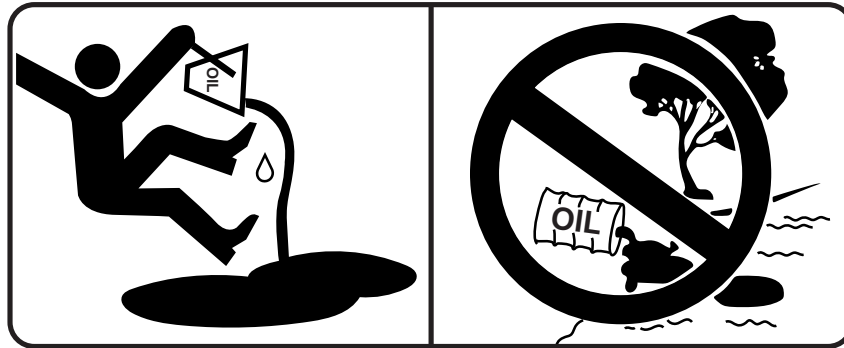

Do not spill or dump oil. Injury could result if not cleaned up.

# 50-155 M & U

Maintenance and Service  
Hydraulic System Maintenance

## Hydraulic System Maintenance

### Maintenance Checks

A regular program of periodic maintenance is an essential part of continued hydraulic system operation. Allowing accumulations of moisture and sediment to build-up in the system will damage hydraulic valves, pumps and motors. The presence of leaking connections or damaged components effect the efficiency of operation and are dangerous. The materials presented here are listed in accordance with the Maintenance Check List. Consideration of severe working conditions may dictate a revision in scheduling periodic checks.

#### Daily:

#### Hydraulic Fluid Level

The hydraulic reservoir, fluid level indicator, and filler cap are on the right side of the machine.

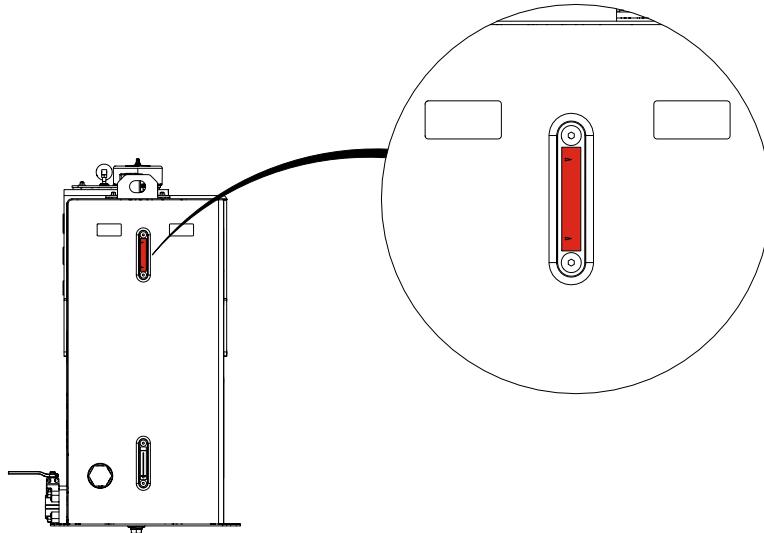

**Hydraulic Oil Fluid Level Gauge - on right side of tank**

Model	Hydraulic Tank Capacity
50-155	165 GAL. (625 Liters)

Retract all cylinders to return the maximum amount of oil to the reservoir and note the oil level in the indicator tube. The fluid level should be kept between the indicator marks. The top mark indicates system capacity with all cylinders retracted. Fluid capacity varies with each model as indicated above.

Do not overfill.

Refer to [Hydraulic Oil Requirements](#) for hydraulic oils meeting the manufacturer's specifications. Do not use oils which have detergent additives.

## 50-155 M & U

Maintenance and Service  
Hydraulic System Maintenance



### Hydraulic Cylinders

Check the cylinder mounting brackets, bushings, and pins for wear, alignment, tightness, and damage. If misalignment or excessive play or wear are detected, replace the defective pin or bushing. Check the rod eye welds for cracks and breaks and have damaged welds repaired.

### Hydraulic Components

Check the hydraulic valves, motors, pumps, hoses, tubes and connections for excess dirt, oil and grease. Clean these items if necessary and check for leaks and damage. Tighten leaky connections and repair any damaged components.

#### Weekly:

#### Return Line Filter

Change the hydraulic reservoir return line filters after the first 40 hours of the break-in period; thereafter, follow the quarterly check recommendation.

#### Monthly:

#### Hydraulic Reservoir

Drain any accumulated moisture from the hydraulic reservoir by parking the machine on a slight incline and loosen the pipe plug in the bottom of the reservoir.

#### Hydraulic Oil

Visually check the condition of the hydraulic oil once each month. Thickening of the oil or a change in its appearance, such as darkening, may serve as a rough indicator of when an oil change is needed. Periodic testing of the oil is the safest, most accurate method of determining the condition of the oil. An oil supplier can be consulted for assistance in testing the oil.

Change the oil whenever testing and/or inspection reveals the oil to be unsuitable for safe and efficient operation or yearly.

#### Quarterly:

#### Hydraulic Filter

Remove and replace the hydraulic reservoir return line filters. Access is gained by removing the cover plate on the right-hand deck plate.

When replacing the filters, clean the spring and bypass valves. Inspect the O-ring for damage and replace if necessary.

## 50-155 M & U

### Maintenance and Service Hydraulic System Maintenance

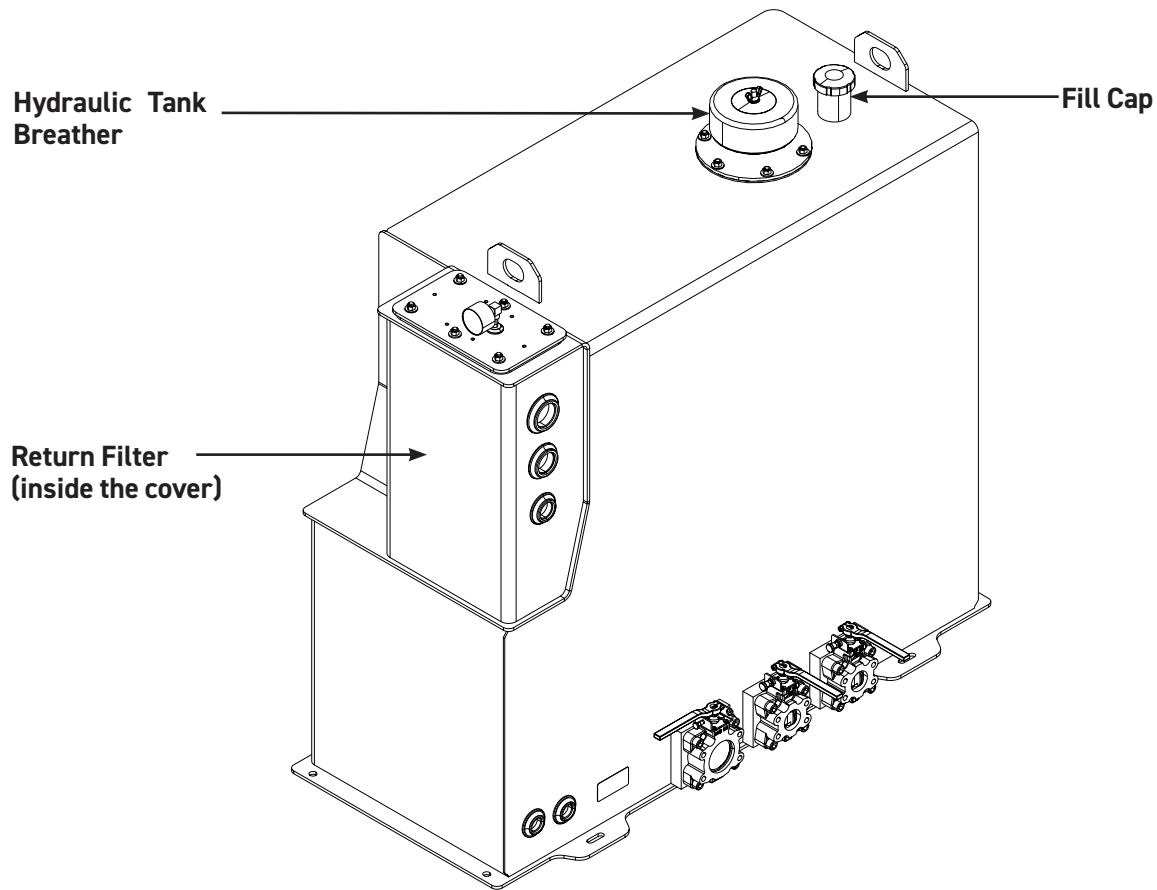

Before discarding the old filter element, examine the type of material trapped in it. This may indicate which, if any, hydraulic system components are deteriorating.

#### 1000 Hours:

#### Hydraulic Reservoir

Drain and clean the hydraulic reservoir. Change the hydraulic oil.

A change interval cannot be established which would apply to all oils and all operating conditions of temperature and cleanliness. However, a reputable brand of turbine grade oil can be expected to deliver 1000 hours of service under average operating conditions. Although conditions may necessitate shorter change intervals, do not use hydraulic oil for more than 1000 hours, unless oil analysis is used.

Whenever a visual inspection, chemical test or light test indicates that an oil change is necessary, proceed as follows:

1. Warm the oil prior to draining but avoid draining immediately after prolonged continuous use to reduce the danger of being burned by hot oil.
2. Retract all cylinders to return the maximum amount of oil to the reservoir. Loosen the top covers and remove the drain plug at the bottom of the reservoir. Allow sufficient time for the reservoir to drain thoroughly.
3. Remove the return filters, clean spring, and bypass valves and inspect cover O-ring for damage and deterioration. Replace the O-ring if necessary.

## 50-155 M & U

Maintenance and Service  
Hydraulic System Maintenance



4. Remove and clean the intake suction filter. This permanent screen-type filter is located inside the reservoir on the intake to the pump manifold. Access to this filter is gained by removing the cover with the filter holding device from the top of the reservoir. Remove the O-ring from the filter and inspect the O-ring for damage and deterioration. If it is damaged or deteriorated at all, replace the O-ring. Clean the filter by immersing it in a non-caustic cleaning solvent. Rub the screen with a soft brush to dislodge accumulated foreign matter.



Keep the cover plates on the reservoir to prevent any contaminants from entering.

5. Clean the reservoir by either steam cleaning or flushing with diesel fuel. If steam is used, steam clean the reservoir thoroughly and allow it to drain and dry completely.
6. If diesel fuel is used to clean the reservoir, replace the drain plug and admit about ten gallons of fuel to the reservoir, preferably under pressure. Allow the fuel to remain in the reservoir long enough to thoroughly clean it. The suction filter may be conveniently cleaned at this time. Remove the drain plug, drain out the fuel and dry out the reservoir.
7. Replace the suction screen and reinstall the cover and filter hold down device.
8. Install a new return line filter. Reinstall the spring, bypass filter and cover.
9. Refill the system with new hydraulic oil as recommended in [Hydraulic Oil Requirements](#).

## 50-155 M & U

### Maintenance and Service Hydraulic Hoses

## Hydraulic Hoses

The service life of a hose used on a mobile crane may significantly vary from the indicated lifetime of the hose from the manufacturer. The service life is influenced by a number of factors, such as environment (including, but not limited to, temperature, humidity, corrosive air) and conditions of use, duty cycles, bending cycles, abrasion, and fluid exposure. Unfavorable external factors like heat, extreme cold, repeated bending under pressure, and exceeding the minimum bend radius of the hose can reduce the lifetime significantly. Other circumstances could allow a service life that may exceed a given period.

### Inspection of Hydraulic Hoses

A daily visual check of the crane by the Operator or a competent service person before starting operation shall include an inspection of the hydraulic hoses as far as possible; any traces of hydraulic oil on the crane or beneath a parked mobile crane shall lead to further investigation. The daily check might indicate irregularities and/or leakages in the hydraulic system that should be taken care of immediately. In addition to these daily checks, **Load King** recommends annual inspections of all hose assemblies as a part of the maintenance of the crane. Older cranes may require more frequent inspections.

### Inspection Criteria:

- Hydraulic hoses should be replaced if any of the following criteria are true:
- Damage on outside surface (cover) of the hose (e.g. crack, cuts, any abrasion that exposes the hose braid (reinforcement)).
- Embrittlement due to the aging of the outer surface (cracking appearing).
- Deformation that does not correspond to the original routing and shape of the hose. This criteria shall be checked in both pressurized and non-pressurized conditions and/or when bending (e.g. check for separation of hose layers, formation of blowholes, crushed points, kinks, torsion).
- Leakage.
- Damage or deformation of hose fittings (sealing functionality affected).
- Movement between hose bulk and hose assembly (e.g. hose creeping out of fitting).
- Corrosion on a fitting that can affect the strength or function of the fitting.

### Recommended Hydraulic Hose Maintenance & Replacement Schedule:

Task	Minimum Maintenance
Checking the hose lines	Annually
Recommended replacement of hose lines	Every 6 years

### Recommendations for the Replacement of Hydraulic Hose Assemblies:

If replacement of hydraulic hose assemblies is required, it is recommended to use original spare parts from the OEM or hose assemblies according to the OEM specification which includes the fittings, bulk hose material and manufacturing process.

## Fluids and Filter Maintenance

### Determining the Condition of the Oil

The only definite way to assure that all accumulated contaminants which will wear the pump, motors, and cylinders are removed from the hydraulic system is to drain the old oil and replace it with new. If oil did not break down or could be kept clean permanently, changing would not be necessary. The easiest way to determine the condition of oil is to obtain a sample from the system and make a visual examination.

Drain some oil from the reservoir into a clean glass container. If it has a burnt or rancid smell, or is cloudy or dark in color, the oil needs to be changed. If water appears in the bottom of the glass after it has stood awhile, there may be either an opening for water to enter into the system, or the unit has been operating under conditions causing condensation. A good example of condensation from extreme temperature changes is when the unit is parked in a warm garage after being out in the cold all day.

The entry and sustained presence of water, solvents, and abrasive dirt will adversely affect the proper condition of the oil. This can cause premature breakdown of viscosity, anti-foam, lubrication, and anti-rust characteristics of the oil. High operating temperatures and water will cause an increase in the oil's oxidation rate. As the oil oxidizes, sludge and varnish forming materials will be deposited in the pumps, valves, cylinders, and lines; thus increasing the rate of wear on the components.

If the oil shows that water is present, or if any other contaminants are suspected, the oil should be changed. Whenever the oil is changed, a new oil filter should always be installed.

Oil contamination can also be tested for contaminate size and content; this may help in diagnosing an issue.

When the oil is drained from the unit and replaced with new oil, the unit must be run for a total of 10 hours after the change before another sample is taken for testing. This will acclimate the oil to the unit and give more conclusive results during testing.

### Selecting the Oil

When buying oil, there is no other single factor more important to the unit's life and economic operation than the quality of the oil used. Protect the oil from losing its proper condition by following the inspection schedules and servicing of filters.

This equipment has been quality engineered for quality oils. The finely machined cylinder and valve components cannot be expected to withstand abuse due to improper care of the hydraulic system. The most economical operation of the hydraulic system results from the use of a premium quality oil and conscientious preventative maintenance in accordance with this manual.

This **Load King** Crane will have been filled with **Shell Tellus S2 V 46** hydraulic oil unless otherwise specified. Only use oil compatible with this crane. Different manufacturer's use chemical formulations which may not be compatible. At a minimum, it must be verified that any makeup oil added is compatible with the oil already in the system.



Observe all oil handling precautions as per the Environmental Protection Agency (EPA). Used oil should be recycled or reclaimed. Remember, oil is not a disposable resource and it is the Owner's/Operator's responsibility to maintain sound environmental practices in regard to used oil and other fluids.

## 50-155 M & U

Maintenance and Service  
Cold Weather, Extreme



Improper or inadequate maintenance of the hydraulic oil or oil filter will result in premature wear to valves, cylinders, motors, and other hydraulic system components.

### Cold Weather, Extreme

The lowest safe operating temperature of a Boom Truck is not in excess of -12°F (-25°C). Operating the machinery in environments that are colder than the lowest safe operating threshold can damage parts, slow the flow of fluids, and delay response times. If the Boom Truck will be operating in temperatures outside these parameters, a Cold Weather Package (CWP) is required to allow the machinery to function and avoid irreparable damage. Even with the CWP installed, proper start-up and operating procedures must still be carefully followed.

### CWP Specifications

A CWP will bring the Boom Truck's approved operating temperature down to -40°F (-40°C).

### CWP Package Components

The following components of the CWP must be installed as listed in the table below. There are a limited number of acceptable lubricants that are effective in extremely cold temperatures. Deviations from the listed approved lubricants must be approved by a **Load King** Service Department.

Description	Specification
Main & Aux. Winch, Swing Drive	Mobil Gear SHC 150 or Shell OMALA HD 150
Hydraulic Oil-see data sheet	Petro-Canada Hydrex Extreme or Shell Tellus Arctic 32
Hydraulic Tank Heater	Driven by coolant/anti-freeze from the truck chassis.
Grease (upper structure & outriggers)	Mobilith SHC 220 Schaeffer 274 Moly EP Shell Alvania EP Arctic Moly 0

Contact your carrier truck supplier for the following cold weather upgrades:

- Engine Oil
- Gear Oil-Front & Rear Axles
- Transmission Fluid
- Coolant Fluid
- Grease (Carrier Chassis)
- Battery Blanket
- Engine Blanket
- Engine Oil Pan Heater

## 50-155 M & U

Maintenance and Service  
Cold Weather Recommendations



### Cold Weather Recommendations

The following recommendations pertain to the operation and maintenance of the Boom Truck in cold weather 32°F (0° C) to -40°F (-40°C). This includes operation of a standard Boom Truck (cold operational threshold no lower than 32°F (0° C)) and CWP-equipped Boom Truck (cold operational threshold no lower than -40°F (-40°C)). Refer to **Load King** Operator's and Installation Manuals before operating the Boom Truck in temperature below 32°F (0° C).



The Boom Truck Operator should familiarize themselves with the CWP components and the following practices for operating in temperatures down to -40°C (-40°F). If the Boom Truck does not have the CWP package installed, use the information in this manual as a guide to properly setup, operate and maintain the Boom Truck during temperatures down to but not exceeding 32°F (0° C).

### Cold Weather Fluid Viscosity Changes

As fluids and oils are changed to CWP-recommended versions, keep in mind that changing out oils and fluids for different viscosities may affect filters, cylinders, and lines. Drain all hydraulic cylinders and lines before changing to CWP-recommended fluids. Be certain to change oil filters and elements when changing oil to a different viscosity. After changing the oil, operate the equipment in order to circulate the thinner oil.



Do not use oil that has been diluted with kerosene. Kerosene will evaporate in the engine. This will cause the oil to thicken. Kerosene will cause swelling and softening of the silicone seals.



Fluids and lubricants must be compatible with the expected temperature of the operating environment. Hydraulic and transmission systems should be drained and purged of old fluids to allow maximum exchange for new fluids. Use CWP-recommended fluids, lubricants, and grease. Use of improper fluids for ambient conditions can damage equipment.

### Cold Weather Parking Recommendations

Take precautions to park the Boom Truck on the most optimal available surface. If necessary, park the Boom Truck on wooden planks as this will keep its tires from freezing to the ground.

### Cold Weather Battery Recommendations

The temperature of the batteries affects their respective cranking power. When the battery is too cold, the battery will not crank the engine, even though the engine is warm. It is recommended that the batteries are either stored in a warm environment or that the Operator uses a battery blanket. Refer to Maintenance Section, CWP Package Components. Ensure that the voltage of battery blanket matches the voltage of the power source.

While operating the machine during cold weather conditions, use the battery charger to keep batteries charged. Full charge prevents batteries from freezing. Ensure that the batteries remain charges to a specific gravity of 1.250 or above.

## 50-155 M & U

Maintenance and Service

Cold Weather Recommendations

### Cold Weather Tire Inflation Recommendations

**Load King** recommends the use of dry nitrogen gas (N<sub>2</sub>) to inflate tires in cold conditions. Using nitrogen gas (N<sub>2</sub>) avoids ice crystals formation around the valve stem, which may hold the valve open. Tire inflation should be done in a heated shop area. The tire bead will seat better when the tire bead is warm. The initial tire pressure should be 15% to 20% higher than the operating pressure in order to seat the bead against the rim. Deflate the tires to operating pressure before operating the crane. The contact surface of the tires will become flat in cold weather when the Boom Truck is parked. To return the tire to a normal shape, move the Boom Truck gradually.

### Inflation Adjustments Needed to Compensate for Lower Outside Temperatures

Desired Cold Inflation Pressure (psi)	Difference Between Shop and Outside Temperature (°F)								
	30	40	50	60	70	80	90	100	110
30	33	34	35	36	37	38	39	41	42
35	38	39	40	41	43	44	45	47	48
40	43	45	46	47	48	50	51	53	55
45	49	50	51	53	54	56	57	59	61
50	54	55	57	58	60	62	63	65	67
55	59	61	62	64	66	68	69	71	73
60	65	66	68	70	72	73	75	78	80
65	70	72	73	75	77	79	82	84	86
70	75	77	79	81	83	85	88	90	92
75	80	82	84	87	89	91	94	96	99
80	86	88	90	92	95	97	100	102	105
85	91	93	96	98	100	103	106	108	111
90	96	99	101	104	106	109	112	115	116
95	102	104	107	109	112	115	118	121	124
100	107	109	112	115	118	121	124	127	130
105	112	115	118	120	123	127	130	133	137
110	118	120	123	126	129	132	136	139	143

### Additional Cold Weather Operation Issues

Contact your **Load King** service representative if there are any questions regarding extreme environment operation or service of crane.

## Cold Weather Starting Recommendations

Machine parts are especially vulnerable during cold weather as dropping temperatures increase fluid viscosity and affect flow. Warm-up times, lead time before use, and preliminary checks take on increased importance during severe cold. For any questions regarding CWP equipment or fluids, refer to the Cold Weather Package Components. Before attempting to start, move, or use the Boom Truck, be aware of the following precautions:

- Preparing to start the Boom Truck
  - Anticipate cold weather and install CWP-recommended fluids before the onset of low temperatures.
  - Ensure that all fluids in the Boom Truck and crane are of the correct type and at the correct levels before attempting to start the machinery.
  - Ensure that the transmission fluid, hydraulic fluids, and engine oil are fluid enough to flow. If engine oil drips from the dipstick, then the oil is fluid enough to start the engine.
  - Check the air cleaner and air intake.
  - Ensure that the voltage of the battery heater blanket, engine coolant heater, and engine block heater match the voltage of their power source.
  - If necessary, use a canvas over the engine compartment and a space heater to warm the engine. Using a canvas tarp over the hydraulic components can help improve their initial warm up.
  - Block the radiator during warm-up; this will restrict air from the fan.
- Starting the Boom Truck
  - Run the engine until the coolant temperature is at least 80°C (180°F) to avoid damage to the valves.
  - Run the engine at less than 1/3 throttle. Slowly move the boom hoist joystick control and lift the attachment in-sequence of raise, lower, extend and retract the boom.
  - Attach a burlap sack loosely to the air cleaner if the equipment is being operated in heavy snow. Keep the burlap sack away from heated parts.
  - Idling the engine keeps the engine compartment and transmission compartment warm.
  - Idling the engine DOES NOT keep the hydraulic system warm.
  - Idling the engine does not warm all systems. It may be necessary to warm other systems individually.
- Walk-around the crane
  - Before entering the Operator's cab, inspect the following parts for cuts, cracks, and worn spots or connections:
    - Hydraulic hoses
    - Tires
    - Fan drive belts
  - Check the outer wrapper of hydraulic hoses. The flexing of the hydraulic hoses during cold weather can cause this wrapper to crack, even though the hose continues to carry oil under pressure.
  - Check that tires remain inflated to weather-appropriate levels.

## 50-155 M & U

### Maintenance and Service

#### Cold Weather Recommendations

---

- In the crane cab
  - Extend the travel of the cylinders during each cycle.
  - Perform the warming operation for all hydraulic circuits such as winch raise/lower, swing left/right, outrigger raise/lower jack cylinders, and beams extend/retract.
  - Exercise the transmission and power train.
    - Run the engine slightly above low idle.
- Moving the Truck
  - Be aware that even with lower viscosity oils, the hydraulic steering gearbox can react slowly to the steering wheel movement while driving.
  - Operate the crane only with light loads until the systems reach the normal operating temperatures.
  - Retained Heat: Be aware that the engine's cooling and lubrication systems do not lose heat immediately upon shutdown.
  - Rapid Cooling: Be aware that due to their large, exposed areas, a vehicle's transmission and hydraulic systems lose heat more rapidly than other components.
  - Rapid Cooling: Be aware that gear cases cool rapidly, since they do not become as warm during operation as other components. Although an engine can be restarted after a few hours' shut down, other systems will require exercising (cycling) after restart.
  - Fill the fuel tank at the end of each shift.

## Aluminum Decking and Fender Maintenance Procedure

Salt spray, road salts, lime dust, battery acid, or mildly corrosive liquid can cause oxidation or etching of the aluminum, which will discolor the surface. A number of methods are used to stop the corroding effects of oxidation on the surface. All metals will corrode in the presence of salts. Though aluminum does not exhibit rusting like steel does, it will develop a chalky film and pitting in the metal surface when exposed to salt for a long periods. A neutral soap and water wash will help remove the oxidized film. If the oxidation has built up for a long time, a buffing wheel will help remove this oxidation from the surface. To stop the corrosive effects, it is necessary to apply a protective coating to the aluminum and keep the coating maintained over time.

### Preventing Salt Damage

To prevent corrosion of aluminum from salts or other materials listed, inspect the material regularly and repair any damage to the surface as soon as possible. Avoid using acidic cleaners on the aluminum and do not use abrasive compounds or materials that will scratch the surface. Damage to the coating will allow salt to penetrate the wax to the metal surface.

1. Use a power washer with soapy water. Rinse the decking and fenders thoroughly and allow to air dry.
2. Apply a metal cleaner such as **Mequiar's Hot Rims Aluminum Wheel Cleaner** which will remove any chalking or hazing.
3. If desired, apply two coats of wax, buffing the wax between each coat. With a cotton cloth or rag, apply to a 3-foot section and buff off the polish. Repeat this process over all the metal surfaces. This will protect the finish and help preserve the durability of the decking.

## 50-155 M & U

Maintenance and Service  
Operator's Cab HVAC

### Operator's Cab HVAC

#### Monthly Sight Check - Operator's

The following checks must be carried out monthly by the Operator:

1. **State of heating hoses and refrigerant hoses** - Check the connections, check for leaks and routing of the hoses and fittings. The hose clamps are to be tightened if necessary.
2. **Electric** - Check electric connections are mated and retained.
3. **State of the Evaporator** - Heat Exchanger
  - o Clean contaminated evaporator. The cleaning is carried out by blow-out or spraying. Do not use a high pressure cleaner.
  - o Adjust any fins pushed down by external influences.
  - o Check thermostat tracer on leaks and position.
4. **Filter - Recirculation** - Check foam filter (2) located behind the Operator's seat by removing the protective grill (1) and check for contaminants. Clean with air pressure or change filter.
  - o Do not let filter get in contact with water.

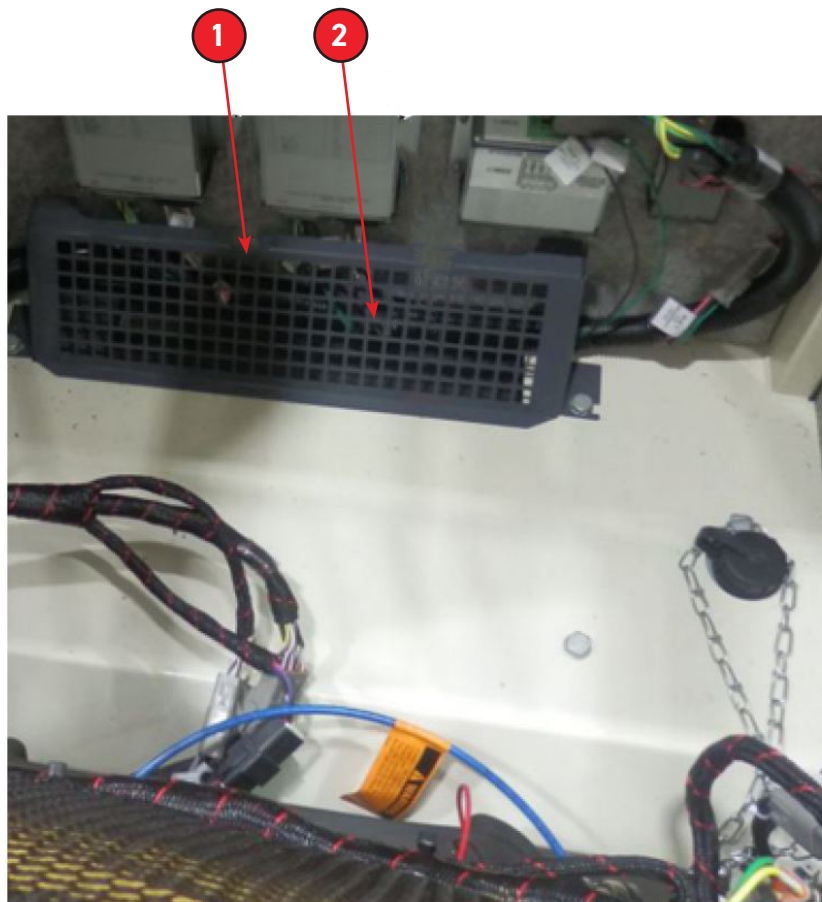

5. **Fresh Air Intakes** - Check air inlet louvers on rear of unit for contaminants and clean if necessary.

## 50-155 M & U

Maintenance and Service  
HVAC Fault Diagnostics



6. **Fresh Air Intake Filter** - Check fresh air intake paper filter at rear of unit and clean if necessary. Do not use high pressure air on filter or allow water to contact filter.
7. **Condensation Drain Tube** - Ensure tube located at bottom of unit is not clogged.

### Every 6 Months - Authorized Workshop

The complete HVAC unit must be checked twice a year through the well-informed personnel of an authorized workshop.

8. **Check of the cooling circuit on refrigerant filling quantity** - Renew contaminated refrigerant and oil.
9. **State of heating hoses and refrigerant hoses** - Check the connections, leak control and laying of the hoses and fittings. The hose connections are to be tightened if necessary. Change hoses if material is worn.

### HVAC Fault Diagnostics

Fault	Possible Cause	Remedy
Blower will not work.	Fuse defective or loose.	Check to see if the fuse is correctly seated. If necessary, insert correctly. Replace defective fuses. If a new defect occurs within a short time this indicates a possible short-circuit.  Examine blowers for a blockage or another type of defect and rectify the cause.
	Interruption of air line.	Test the lines on loose contacts or breaks.
	Blower motor defective.	Replace blower motor.
	4-speed blower switch defective.	Test switch, replace operation element.
Blower cannot be switched off.	Short-circuit in cable or blower.	Rectify short-circuit, if necessary, Replace cable(s) and/or switch.
Blower only operates at reduced power.	Contacts contaminated.	Clean plug contacts. Proceed carefully to avoid.
	Blower switch is defective.	Replace switch.
	Connecting plug has become loose.	Check plug connection of unit for proper seating. If not assemble it correctly.

## 50-155 M & U

### Maintenance and Service HVAC Fault Diagnostics

Fault	Possible Cause	Remedy
Insufficient or no heating power.	Oil supply temperature too low.	Wait until the engine is warm.
	Heat exchanger fins contaminated.	Check heat exchanger and clean it if necessary.
	Filter contaminated.	Clean or replace filter.
		Heat exchanger does not have oil flowing through it.
Air flap not adjustable.	Foreign body blocks flap.	Check flap, remove foreign body.
	Flap bearing defective.	Check and replace flap bearing, if necessary.
	Servo motor defective.	Replace servo motor.
	Operation element defective.	Replace operation element.
Compressor does not work.	Interruption in the magnetic coil of the compressor.	Check current flow to the clutch.
	V-belt loose or torn.	Adjust belt tension, replace belt.
	V-belt slides or does not turn on the v-belt even though coupled.	Check, repair, replace compressor.
	Compressor clutch slides.	Repair clutch or replace compressor.
	Control unit defective.	Check control unit and replace if necessary.
Evaporator flooded.	Expansion valve is stuck in open position and/or clings.	Replace expansion valve.
Evaporator icy.	Thermostat tracer in the wrong position.	Tracer must be repositioned.
	Expansion valve or thermostat defective.	Replace expansion valve, thermostat, or receiver drier.
Evaporator clogged.	Cooling ribs contaminated.	Clean evaporator.
Loss of refrigerant.	Interruption of the refrigerant pipe.	Check all pipes for leaks through external influences or chafing.
	Leak within the unit.	Evacuation, filling, leakage check and repair to be made.

## 50-155 M & U

Maintenance and Service  
Refrigeration Circuit Maintenance Notes



Fault	Possible Cause	Remedy
Cooling performance insufficient.	Air flow too low because filter is contaminated.	Clean or change filter; pay attention to the air flow direction.
	Blower flow impeded.	Check air ducts and outputs for blockages, eliminate fault.
	External air/recirculation air flap position on external air at high external air temperatures.	Set position to recirculating air.
	Too little refrigerant in system.	Carry out leak test, top off system (service filter).
	Moisture in system.	Empty air conditioning unit, exchange receiver drier, evacuate and fill new (service filter).
Unit cools with interruptions.	Power interruption, earth connection faulty or loose contacts in the compressor's solenoid coil.	Check lines, repair or renew as necessary.
Unit making a lot of noise.	V-belts loose or excessively worn.	Increase tension of V-belts or replace V-belts.
	Clutch noisy.	Repair clutch.
	Retainer of refrigerant compressor loose or inside parts defective.	Repair retainer, replace refrigerant compressor.
	Excessive wear of blower motor.	Replace blower motor.
	Refrigerant system overfilled.	Extract refrigerant until high pressure display is normal.
	Too little refrigerant in system.	Carry out leak test, top off system.

### Refrigeration Circuit Maintenance Notes

- The refrigeration system must always be purged before any work is carried out on the refrigeration circuit. This may only be done by a HVAC system specialist.
- Only R134a refrigerant must be used with 260 cc Sanden SP-15 refrigerant oil.
- No florescent additives may be added to the refrigerant.
- Never heat up refrigerant bottles with a naked flame.
- Do not discharge refrigerant to the environment.
- Liquid refrigerant must not come into contact with the skin.
- Safety glasses and gloves must be worn when handling refrigerant.
- Under no circumstances is the unit to be rinsed with compressed air.

# 50-155 M & U

Maintenance and Service  
Master Lubrication Chart

## Master Lubrication Chart

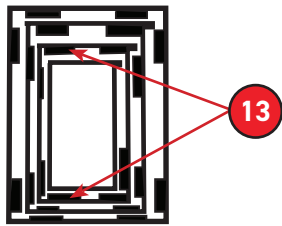

BOOM

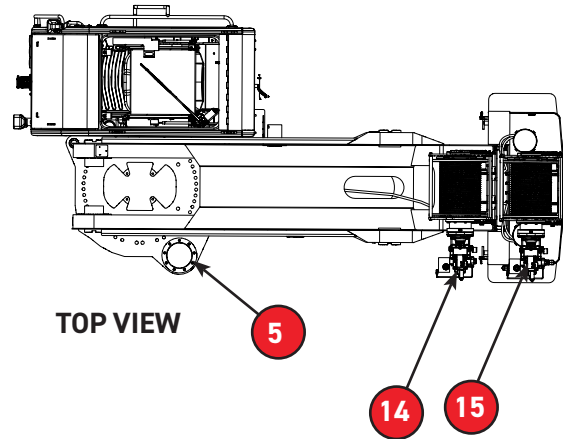

TOP VIEW

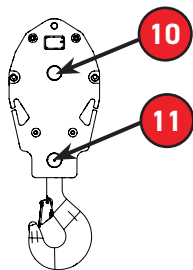
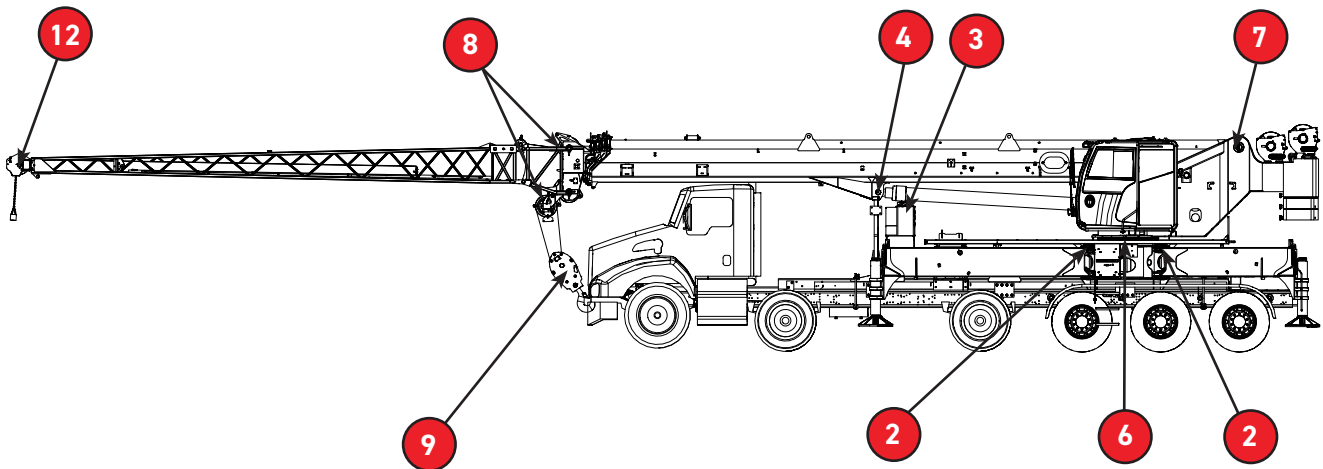

BLOCK

**50-155 M & U**  
Maintenance and Service  
Master Lubrication Chart



	DAILY (8 HOURS)	WEEKLY (40 HOURS)	TWO WEEKS (80-100 HOURS)	THREE MONTHS (250 HOURS)	FOUR MONTHS (500 HOURS)	SIX MONTHS (1000 HOURS)	YEARLY (1500-2000 HOURS)	REF	DESCRIPTION	QUANTITY	NO.	LUBRICANT
								1				
	LUB							2	OUTRIGGER LEG PIVOT ARMS	AS REQ'D	8	MPG
CHK	INITIAL		INITIAL				D/R	3	HYDRAULIC RESERVOIR	HO - SEE TABLE 2 - KEEP OIL LEVEL BETWEEN MARKS ON INDICATOR TUBE		
	LUB							4	BOOM CYLINDER BUSHINGS	PURGE	2	MPG
LUB								5	TURNTABLE GEAR, PINION *	20 SHOTS	1	CG (MPG BELOW 32° F)
		LUB						6	TURNTABLE BEARING RACE *	AS REQ'D	1	MPG <span style="border: 1px solid black; padding: 2px;">BELOW 32°F: EP-1 ABOVE 32°F: EP-2</span>
	LUB							7	BOOM PIVOT PIN	PURGE	2	MPG
	LUB							8	BOOM TIP SHEAVES	PURGE	5	MPG
	LUB							9	HOOK BALL	PURGE	1	MPG
	LUB							10	HOOK BLOCK SHEAVES	PURGE	7	MPG
	LUB							11	HOOK BLOCK TRUNNION	PURGE	1	MPG
	LUB							12	JIB SHEAVE	PURGE	1	MPG
	LUB							13	BOOM SLIDE PADS	AS REQ'D	24*	MPG
			*CHK		D/R			14	WINCH PLANETARY GEAR	FILL PLUG LEVEL*	1	TEXACO MEROPA 150 OR EQUIV. AGMA No. 4EP GEAR OIL
			*CHK		D/R			15	AUX. WINCH PLANETARY GEAR	FILL PLUG LEVEL*	1	TEXACO MEROPA 150 OR EQUIV. AGMA No. 4EP GEAR OIL
					CHK			*	CHECK TORQUE ON BOLTS *	AS REQ'D	-	N/A

**TABLE 1**

LEGEND:

- CHK.....CHECK
- LUB.....LUBRICATE
- .....CHANGE FILTER
- D/R.....DRAIN & REFILL

\*REFER TO OPERATORS MANUAL

**TABLE 2**

SPECIFIED LUBRICANTS		
MPG	MULTI-PURPOSE GREASE	EP-2
GG	OPEN GEAR GREASE	Grade B
GL-1	GEAR LUBRICANT, REGULAR	STRAIGHT MINERAL OIL SAE 80W-90
GL-5	GEAR LUBRICANT, EP	SAE 90 (MI1-L-21058)
HO	GEAR LUBRICANT, EP	*Lubrication Spec. 805
	HYDRAULIC OIL	
*REFER TO OPERATORS'S MANUAL FOR COMPLETE LISTING OF RECOMMENDED OILS FOR APPLICABLE TEMPERATURE RANGES AND FOR DRAIN/REFILL PROCEDURES.		

NOTE:

Reduce all lubrication intervals under severe operating conditions. Refer to Operator's Manual for drain/refill procedures and additional information. Check outrigger beams daily and remove excess dirt.

2. See Chassis Manufacturer's Maintenance Manual for lubricants.

# 50-155 M & U

Maintenance and Service  
Hydraulic Oil Requirements

## Hydraulic Oil Requirements

The hydraulic system is filled with **Shell Tellus S2 V 46** premium hydraulic oil. This hydraulic oil is recommended for a broad range of operating temperatures, but the end user is ultimately responsible for determining if the oil is appropriate for their specific operating conditions or if another hydraulic oil is required. To ensure the longest life for this piece of equipment, it is critical to maintain the hydraulic oil at the proper level, to keep the hydraulic fluid clean (see Hydraulic Maintenance sub-section), and to avoid overheating the oil.

The oil for the hydraulic system performs multiple functions. While the hydraulic oil must transmit power and provide superior lubrication under high pressure, there are other properties that are critical to the oil and the performance of the equipment. These include, but are not limited to, wear protection, oil oxidation, rust and corrosion protection and foaming. To guide in the selection of the proper oil, refer to the Oil Viscosity Selection Chart below and the listings of [Typical Qualified Hydraulic Oils](#) in the following pages.

### Oil Viscosity Selection Chart

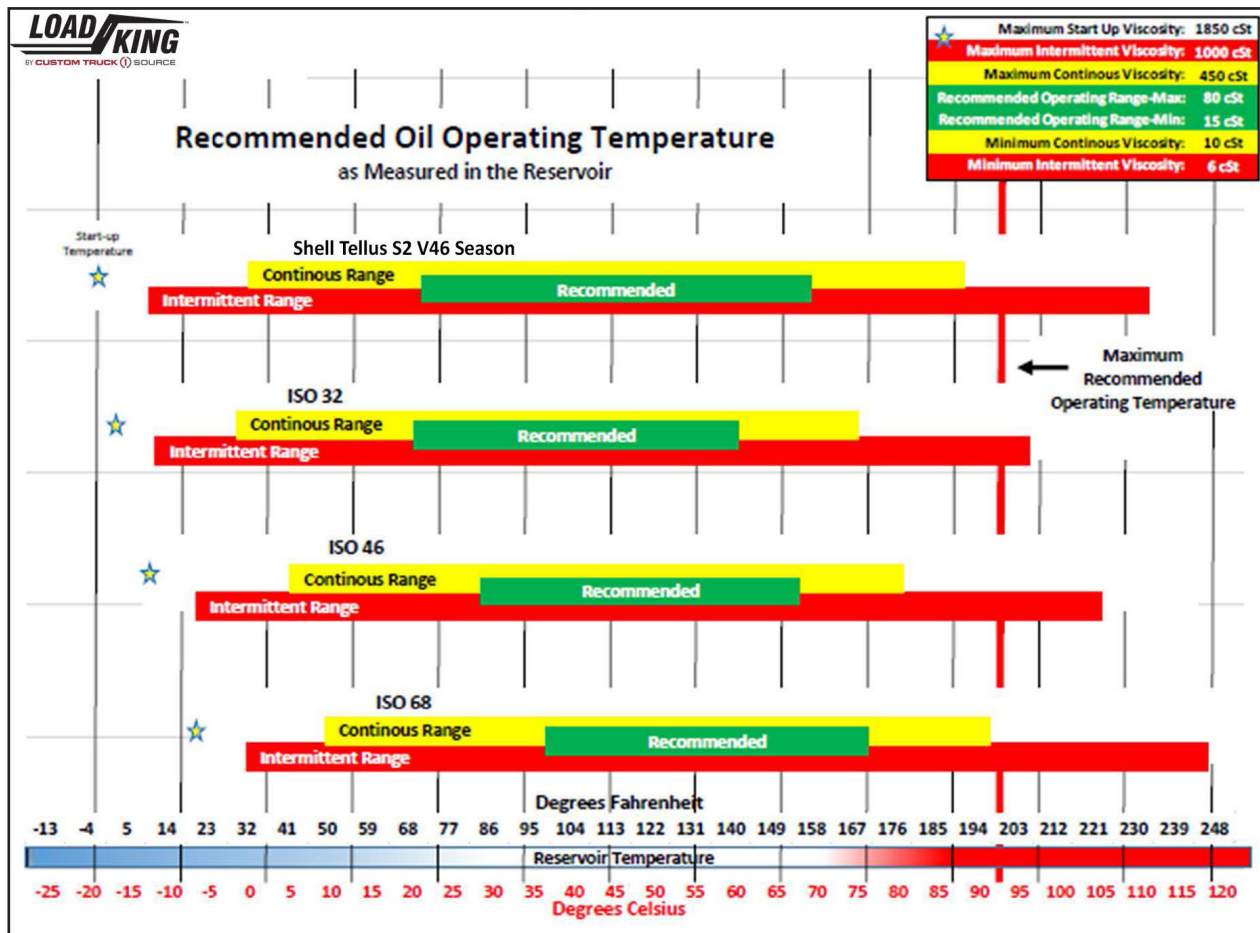

Oil Viscosity Selection Chart Color Legend

GREEN	Recommended - Component Manufacturer's Optimal Range
YELLOW	Continuous - Component Manufacturer's Limits for Continuous Operation
RED	Intermittent - Limited Operation Range

## 50-155 M & U

### Maintenance and Service Hydraulic Oil Requirements



The factory-filled hydraulic oil is recommended for most operating conditions and for a wide range of oil operating temperatures as measured in the reservoir. Under certain operating temperatures and conditions (duty cycles), it may be advisable to use another fluid in order to maintain the oil viscosity in the recommended range (see [Oil Viscosity Selection Chart](#)). For startup temperatures lower than what is indicated in the chart, follow the warm up procedures in the operating manual to increase the fluid temperature and decrease potential damage. Additionally, these machines should not be operated with hydraulic reservoir temperatures in excess of 200°F (93°C). These high temperatures cause degradation of the hydraulic fluid and rubber components such as hoses and seals.

If overheating occurs, discontinue operation and:

1. Check the hydraulics fluid level.
2. Check the oil cooler for plugs or restricted air flow.
3. Check that the oil viscosity matches that recommended for the operating temperature.
4. Check pressure settings – Is a pump failing or a relief set to low?
5. Reduce the duty cycle of the machine.
6. Consult an authorized **Load King** Dealer.

The following hydraulic oils are not recommended:

- Engine Oils
- Transaulic Oils
- Zinc-Free Hydraulic Oils
- Transmission Fluids

## 50-155 M & U

Maintenance and Service  
Hydraulic Oil Requirements

### Typical Qualified Hydraulic Oils

Oil Company	ISO	Brand Name	Oil Company	ISO	Brand Name
Conoco	32	Conoco DN 600 (Arctic)	Northland Products (USA)	32	Talamar 150
		Conoco Super Hyd. 5W-20 (Multi-Viscosity)		46	Talamar 215
		Conoco Super Hyd. 32		68	Talamar 315
		Conoco Super Hyd. 46		46	Talamar All-Season Premium (Multiviscosity)
Exxon Co. (USA)	32	Nuto-H 32	Pennzoil Products Co. (USA)	32	Talamar Extreme 32
		Nuto-H 46		46	Talamar Extreme HTA
		Nuto-H 68		68	68
Imperial Oil Limited (Canada)	46	Nuto-H 32	Shell Co. (USA)	32	AWX Multi-Viscosity
		Nuto-H 46		46	AW 32 Hyd. Fluids
		Nuto-H 68		68	AW 46 Hyd. Fluids
Kendall Refining Co. (USA)	68	Kenoil R & O AW 32	Texaco Inc. (USA)	32	AW 68 Hyd. Fluids
		Kenoil R & O AW 46		23	Tellus 23
		Kenoil R & O AW 68		32	Tellus 32
Mobil Oil Corp.	68	Nuto-H 32	Texaco Inc. (USA)	46	Tellus 46 (XSL 9101)
		Nuto-H 46		68	Tellus 68
		Nuto-H 68		32	Rando Oil HD A2 (5w-20)
				46	Rando Oil HD 32
				68	Rando Oil HD 46
				68	Rando Oil HD 68

## Boom Lubrication

This procedure will require two (2) people; one to operate the boom to position the grease zerks in the access holes and the other person to grease the boom and signal the Operator when the zerks are aligned with the holes. A stable working platform is required for this procedure.

1. Fully extend the front and rear outriggers, then level the retracted boom over the front of the machine.



All lubrication operations in this procedure specify the use of **Berulub PAL1 Grease (Bechum)** or **Northland Moly Tac II Grease Lithium Complex**. Do not intermix the above products due to their chemical compositions.

2. Using the grease compound as specified above, lubricate the upper rear wear pads of the boom that ride on the inside top plate of the base section. Use a grease gun with a flexible hose and insert through the small holes along the side of the base boom as they line up with the zerk as shown in the following figure.

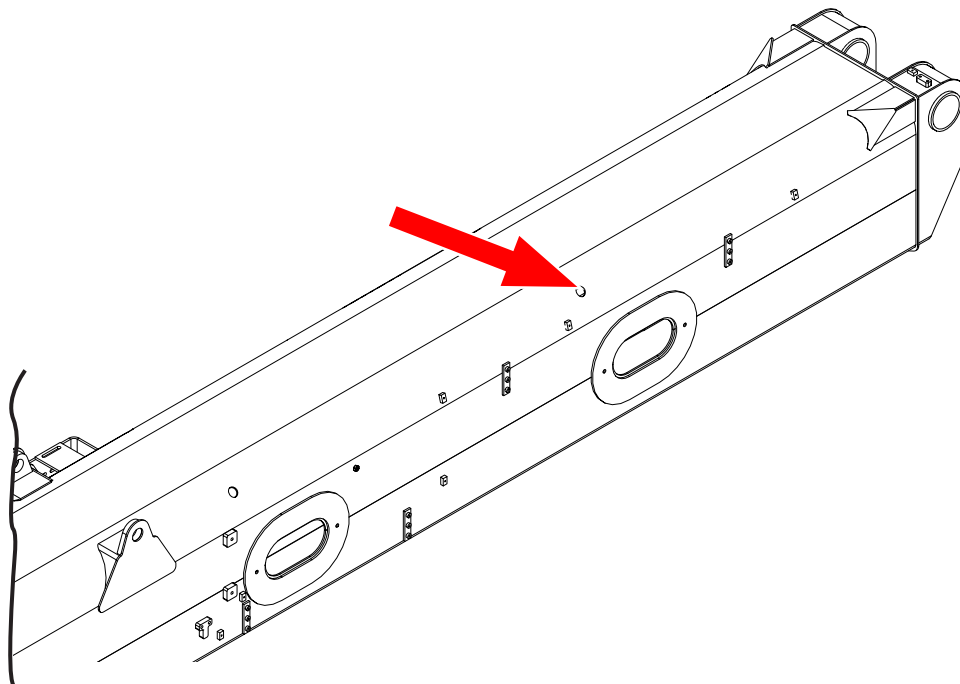

3. With a person on an elevated platform, have the crane Operator slowly extend the boom until the first access hole in the base boom section lines up with the zerk in the second section. Grease the zerk on each side of the base boom with ten (10) shots.
4. Repeat previous step for each of the access holes going forward on the base boom as the second section is extended approximately 3 feet each time. The last hole in the base boom will line up with the zerk when the second section is fully extended as shown in figure below.

## 50-155 M & U

### Maintenance and Service Boom Lubrication

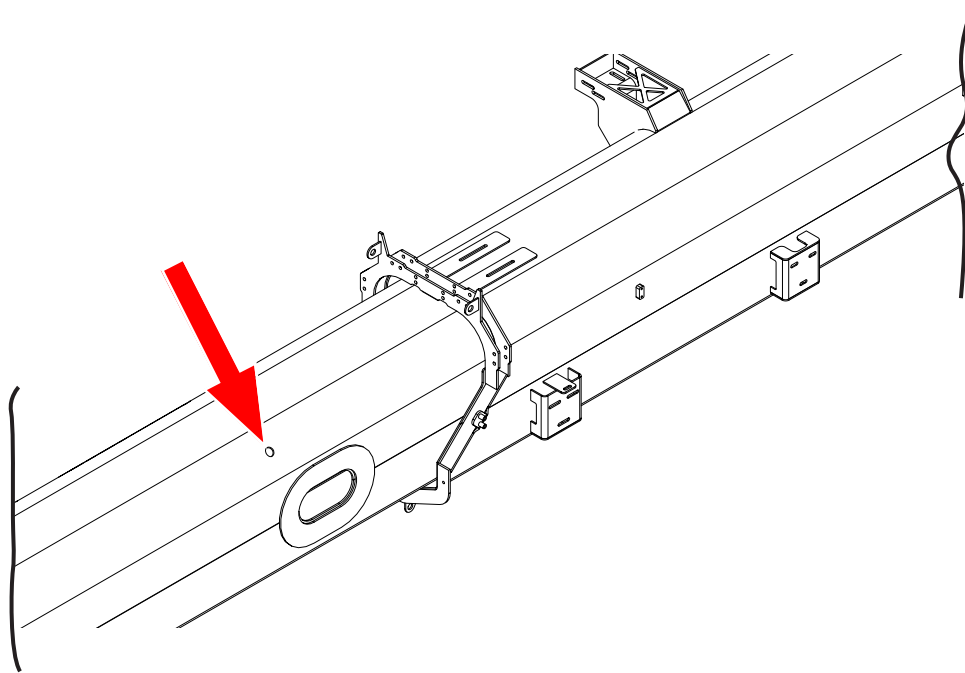

5. Extend the second section to line up the 1<sup>st</sup> zerk hole in the second section of the boom with zerk in 3<sup>rd</sup> section. Grease the zerk on each side of the 2<sup>nd</sup> section with ten (10) shots as shown.

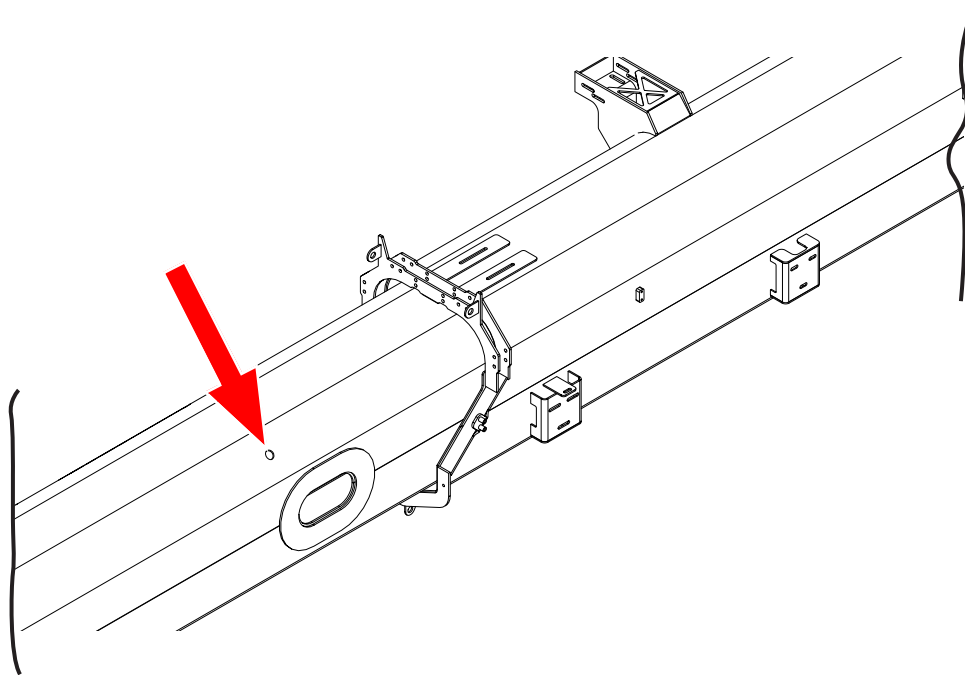

6. Repeat previous step for each access hole going forward in the second section as the 3<sup>rd</sup> section is extended. Line up the zerk and apply the grease.
7. With the second section fully extended, use a roller or brush to grease the bottom and both sides of boom on surfaces where wear pad contact is seen as shown below.

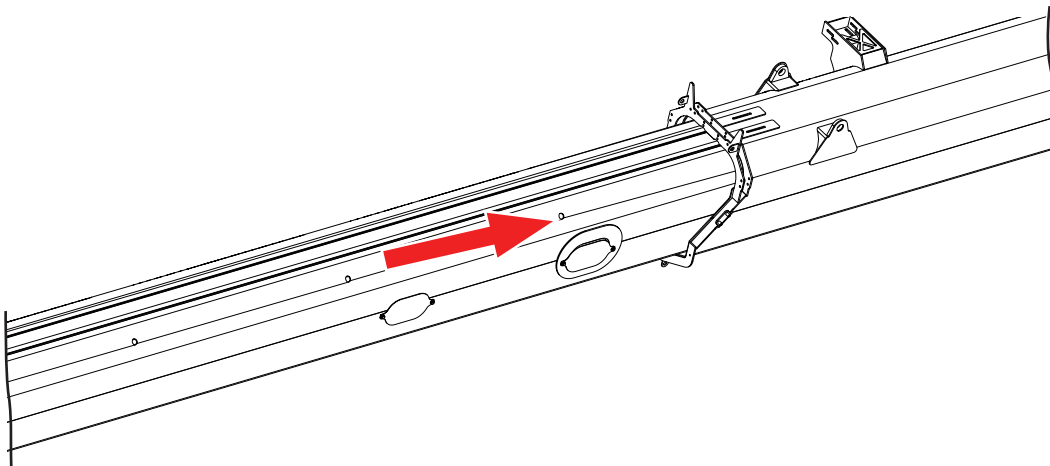
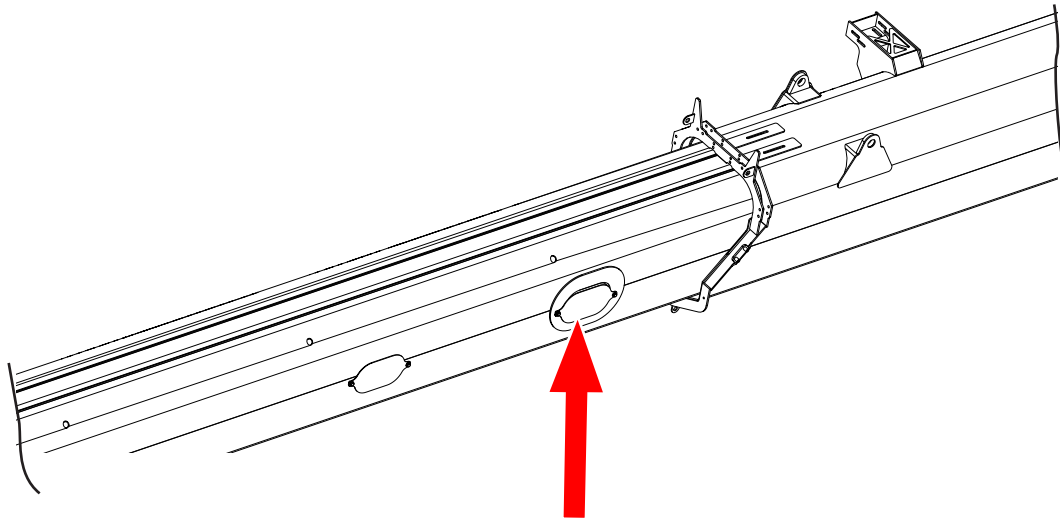

8. Fully extend the boom, one cylinder extends section 2, and the other cylinder extends section 3, 4, and 5.
9. Grease the bottom and both sides of boom sections 3, 4, and 5 on surfaces (similar to step 8) where wear pad contact can be seen.



Do not stick hands or tools in boom sections until the engine is shut off and the PTO is disengaged. Serious injury will result if the boom is telescoped while hands or tools are in the holes.

10. Internal access to the boom sections via the large port holes is now possible on the 2, 3, 4, and 5 sections as shown.

## 50-155 M & U

### Maintenance and Service Boom Lubrication

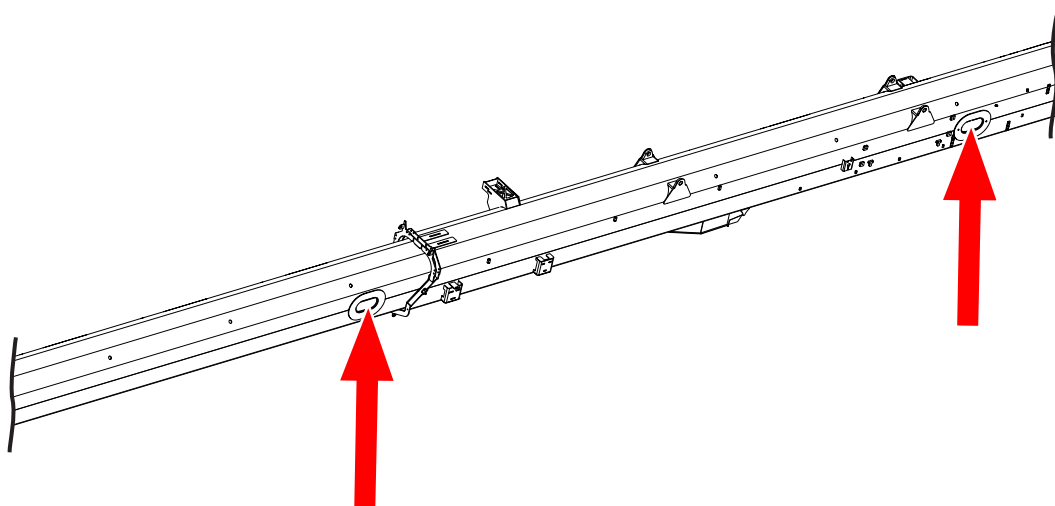
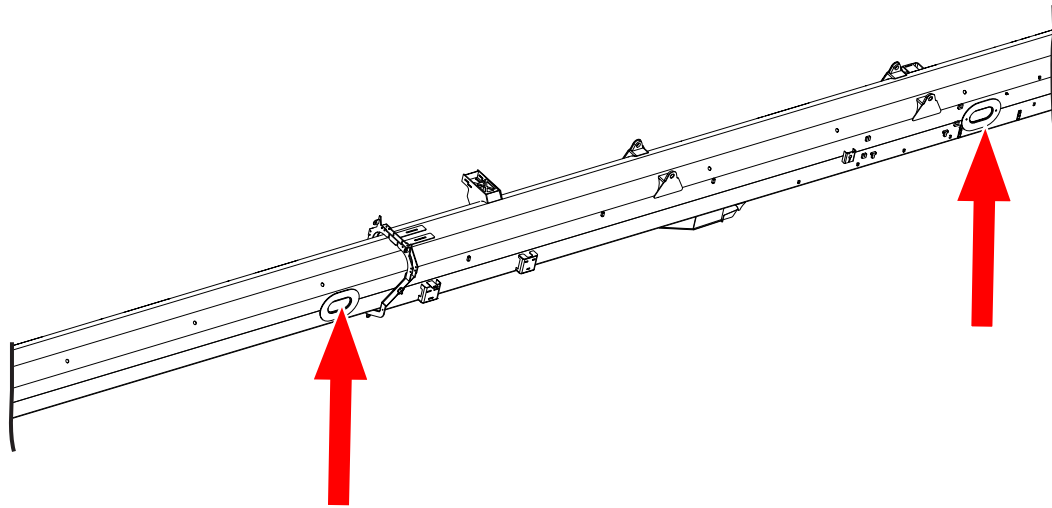

11. Using a roller that is 3"-3 1/2" wide, roll grease to the top and bottom of each section where the wear pads can be viewed through each port hole. It should be evident where the wear pads have made contact with the metal surfaces. Apply the grease to these areas as shown.



## 50-155 M & U

Maintenance and Service  
Boom Lubrication

12. No greasing of the 5<sup>th</sup> (tip section) is required. Cycle the boom in and out a few times to distribute the grease evenly between the wear pads before starting normal crane operation.
13. To lubricate the base boom pins, locate the two (2) zerks - items 3 on each base boom pin as shown in photo below. Lubricate until grease starts extruding from the end of the tube. Repeat on other side of boom.

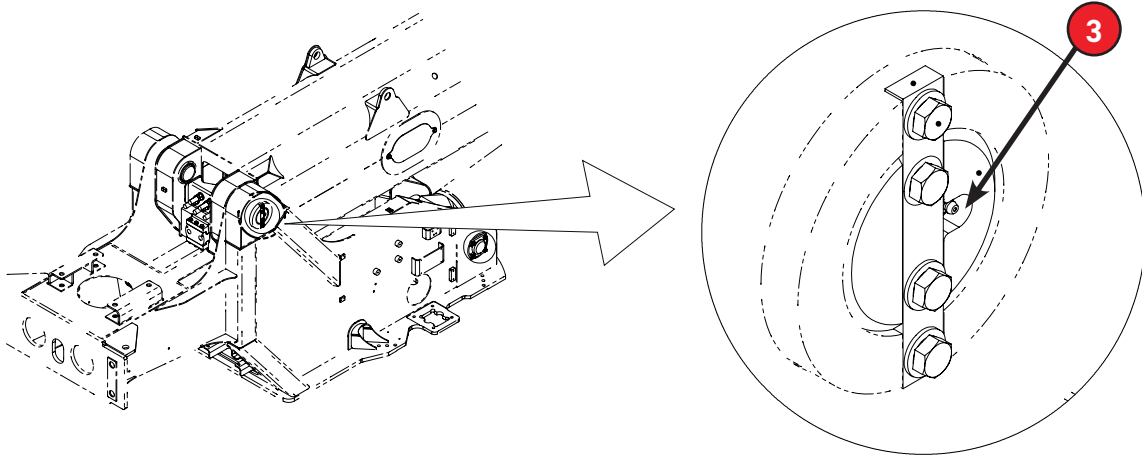

The engine must be turned off before attempting sheave lubrication. Serious injury may occur if attempting lubrication with the engine on.

14. To lubricate the boom head sheaves, set the outriggers, retract and lower the boom, and place the hook block on the ground. Shut down the engine. All sheaves require lubrication. The top set of sheaves (shown in left photo below) have one (1) zerk per sheave, and require three (3) to four (4) shots of grease per sheave. Lower sheaves (7) (shown in right photo below) each have a zerk which can be accessed by aligning web holes to get to the inboard sheaves.

## 50-155 M & U

Maintenance and Service  
Swing System Maintenance

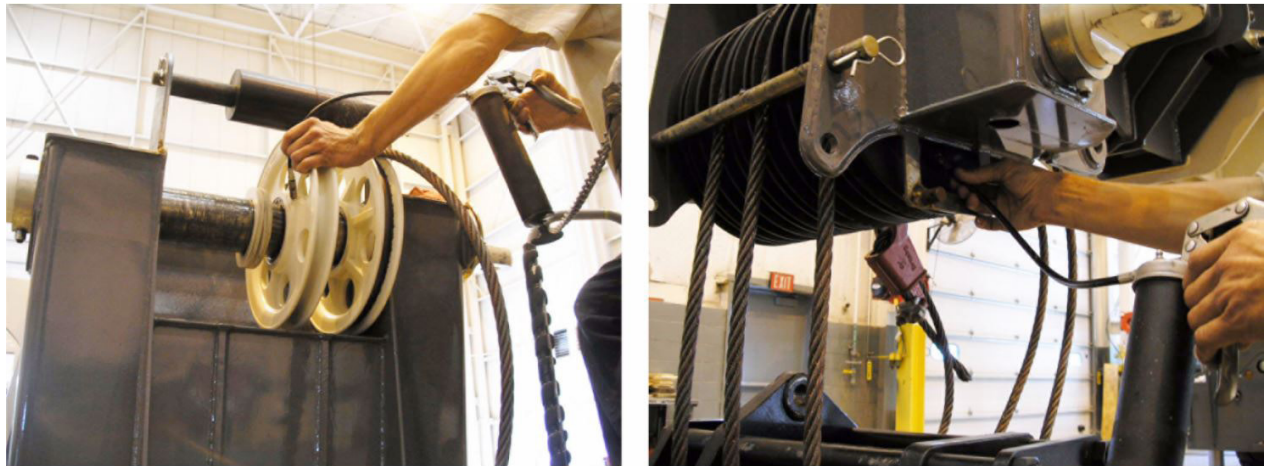

### Swing System Maintenance

#### Swing Lock Maintenance

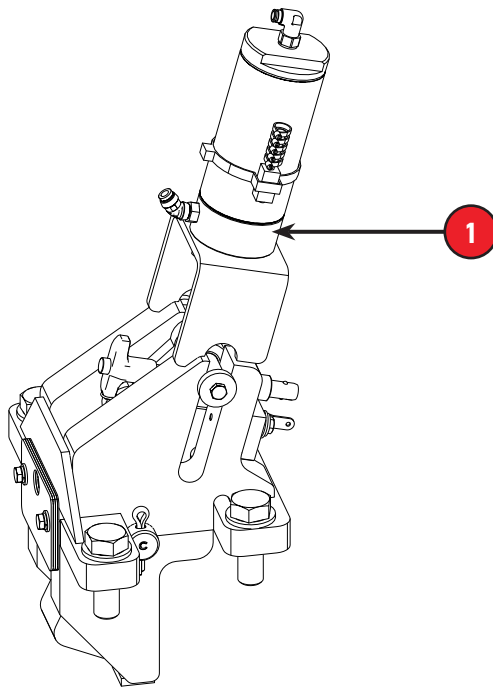

Daily check operation of Swing Lock air cylinder (1) and pin engagement. If the cylinder stroke is not fully extending or retracting, check the air pressure to cylinder extend and retract port and electrical connector at the cylinder.

## Swing Reducers

1. On a weekly basis, check the swing reducers oil level and add oil as needed to maintain the top level when item (1) plug is removed. Recommended lubricant is AGMA 4EP Gear Oil or equivalent.
2. Keep case breather item (2) clear of dirt and debris.
3. All swing drive gearboxes from **Load King** are shipped with an additive to the gear oil of 5 oz (148 ml) of ethylene glycol for cold weather protection. If gear oil in the unit is changed, **Load King** recommends the same amount of ethylene glycol is added to prevent freeze up of unit due to internal condensation.

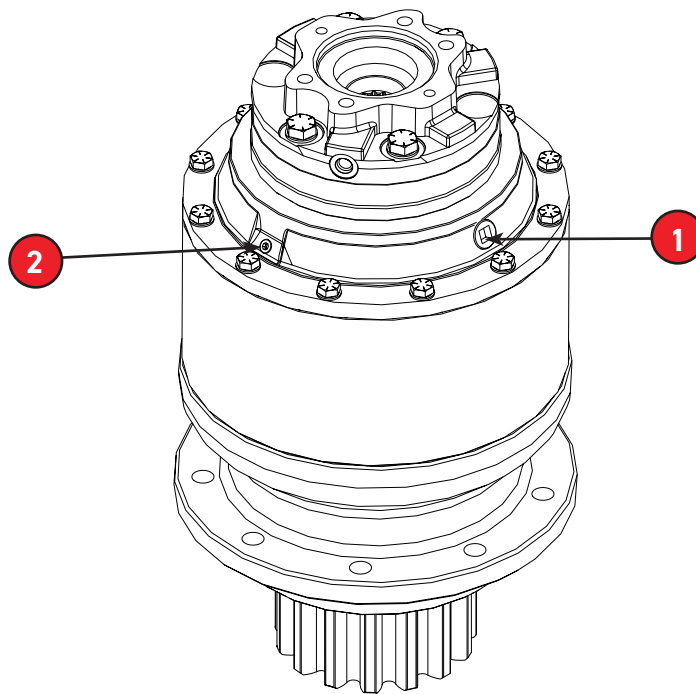

1. Fill Port
2. Case Breather

# 50-155 M & U

## Maintenance and Service Swing Bearing Bolting Procedure

### Swing Bearing Bolting Procedure

#### Maintenance Check

It is important to perform periodic swing bearing bolt checks. The bolts **MUST BE KEPT TORQUE TIGHTENED** to a rating as indicated in chart below. After the first day, and again after the initial 40 hours of machine operation, check and tighten the bolts. If additional torque is required after the first 8 or 40 hours, then recheck each 8 or 40 hours until all bolts are found properly torqued. Thereafter, checks should be performed quarterly.

Model	Lubricated	Dry
50-155	511 FT. LBS. (963 NM)	682 FT. LBS. (925 NM)

Bolt torques are checked by applying the stated torque while observing to determine if the bolt "breaks loose". If it is tightened (turned) by this procedure then it has loosened and all (30) bolts must be re-torqued. Refer to the sequence illustrated below.

Ring Gear Bolting Sequence - (shown below).

The diagram illustrates the bolting sequence for a ring gear. It shows a circular gear with 30 bolts numbered 1 through 30. The bolts are arranged in a circular pattern around the gear. The diagram includes labels for 'REAR' and 'FRONT' views, and a 'NEW PIN' label. Callout 'A' with arrows points to specific bolt locations. The gear is shown in a cross-sectional view with dashed lines indicating the internal structure and the location of the bolts.

198

## 50-155 M & U

Maintenance and Service  
Swing Bearing Bolting Procedure



### Swing Bearing Torque Procedure

A number of causes can reduce tension in the bolts when torquing and after use. These include rust on the threads, damaged or rough threads on bolts or nuts, shanks of bolts which hang up on holes, etc. All of these causes have a tendency to absorb the torque when bolts are being tightened.

All the fasteners inside the upper structure and the four outside must be checked. This includes a total of thirty (30) cap screws to be checked. If ANY are found to have loosened, ALL thirty (30) must be re-torqued.

Remember, it is important to perform periodic checks of the swing bearing bolts. The bolts **MUST BE KEPT TORQUE TIGHTENED.**

The following equipment is required for checking swing bearing bolt torque:

#### Description

- (1) 3/4 drive ratchet head torque wrench with 200 lb. capacity
- (1) 16" extension - 3/4 drive.
- (1) 8" extension - 3/4 drive
- (1) 7/8" 12 pt. socket - 3/4 drive.
- (1) special wrench pn. 706F8697.
- (1) 4 to 1 torque multiplier.
- (1) 1" 12 pt. socket-3/4 drive.

## 50-155 M & U

### Maintenance and Service Slider Pad Maintenance and Lubrication

#### Slider Pad Maintenance and Lubrication

The front bottom slider pad should be checked daily for wear. The remainder of the slider pads should be checked monthly for wear.

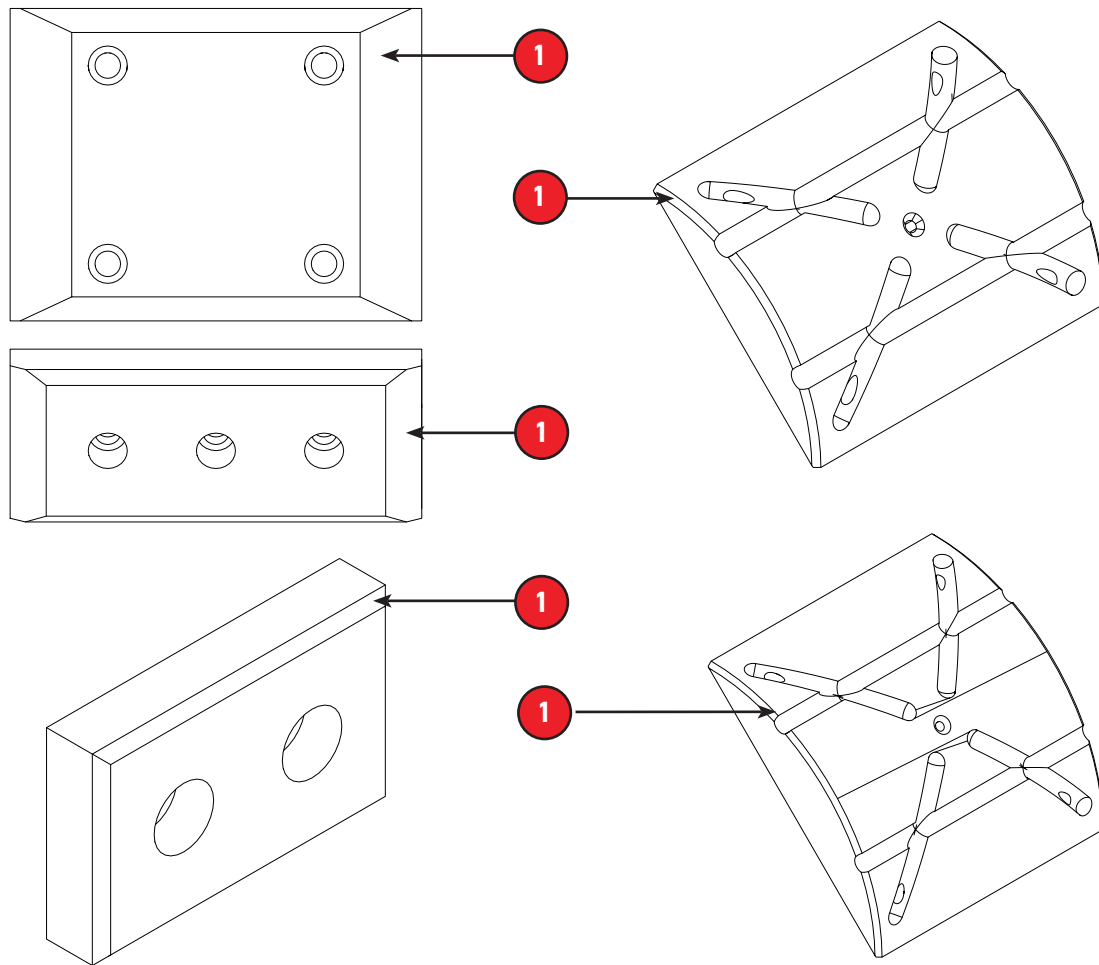

All the slider pads have a chamfer (1) on the wearing surface. When this chamfer (1) is worn off, the slider pad must be replaced.

With the boom extended, brush grease on interior areas of the boom where wear pads contact is evident. The inside of the top plate of all sections except the tip section also require grease. This can be applied through the holes in the side plates and “piled” on top of the next section out just in front of the top rear pads on that section so that extending the boom to the next hole smears the grease onto the inside of the top plate. Remember to do both sides.

Grease intervals vary and should be more frequent if noise or jerking of the boom is evident.

**Turntable and Swing Pinion**

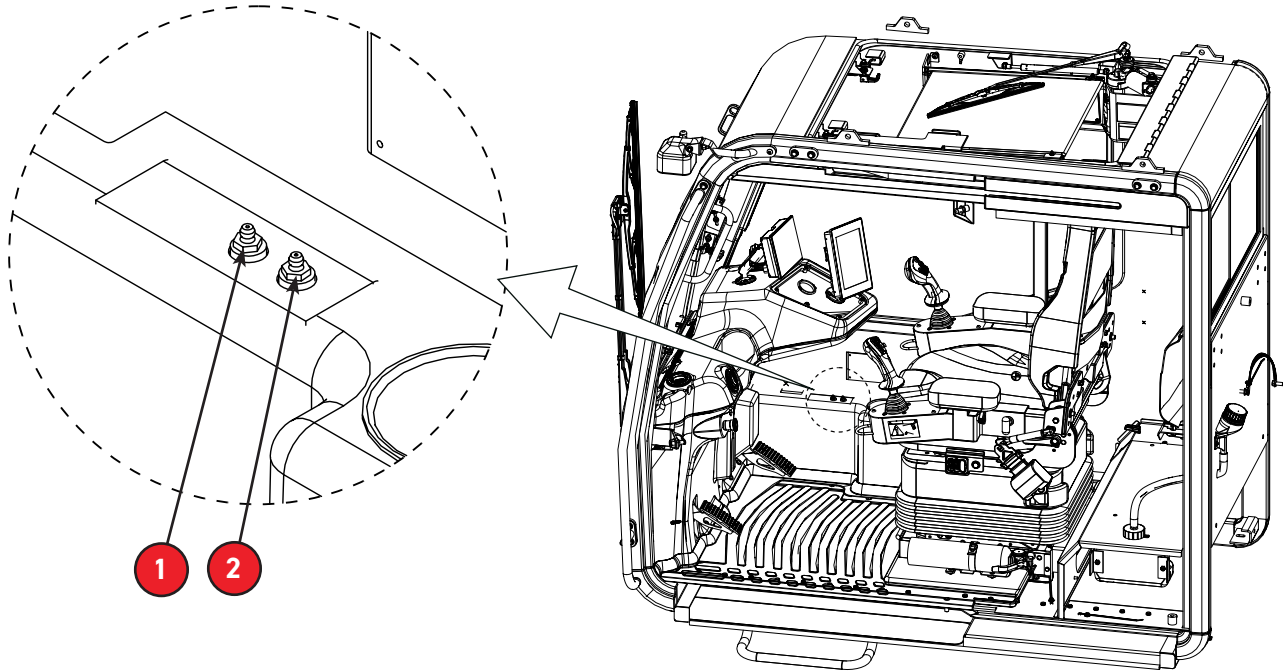

- |                              |
|------------------------------|
| 1. Swing Bearing Grease Port |
| 2. Swing Gear Grease Port    |

Lubricate every 100 operating hours as follows:

Inject grease as recommended below through both grease zerks item (1) and (2) located in the operator's cab on the right console, to the right of the Operator's seat. The superstructure is to be slowly rotated at least two complete revolutions while injecting grease. If complete rotation is impractical, inject grease through each fitting and rotate the superstructure back and forth as far as possible as each fitting is greased.

Under extremely dirty or dusty conditions, sufficient grease should be added to flush out contaminated grease. Under less severe conditions, add grease until it appears at the bottom seal.

While swinging the machine, apply gear grease to the external ring gear with sufficient frequency to ensure that the teeth remain coated.

Lubricants recommended by the manufacturer are as follows:

	<b>MOBIL</b>	<b>TEXACO</b>	<b>SUNOCO</b>	<b>AMOCO</b>	<b>EXON</b>
RACE	Mobilux EP1	Mutifak EP1	Prestige 742EP	Amolith EP1	Beacon EP1
GEAR	Mobilux EP1	Mutifak EP1	Prestige 742EP	Amolith EP1	Beacon EP1

## 50-155 M & U

Maintenance and Service  
Wire Rope and Reeving



Other manufacturer's lubricants of the same quality are suitable.

## Wire Rope and Reeving

### Maintenance

All wire ropes in active service should be inspected along with spooling, sheaves, wedge sockets, and any other wire rope fittings for damage. Once weekly a through wire rope inspection should be made by a competent inspector. A record should be kept of the inspections using the form [Wire Rope Inspection Record](#).

Use appropriate personnel lifting devices or ladder in order to inspect the ropes on the winches.

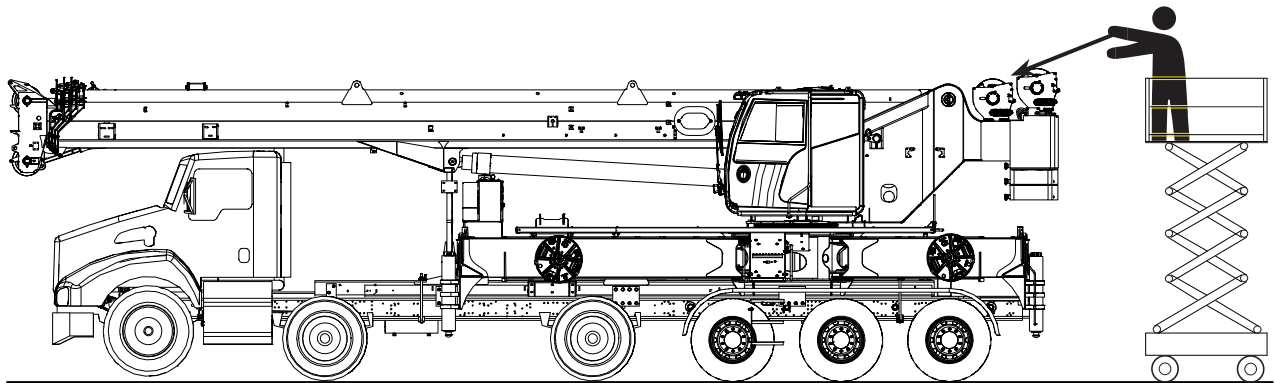

Refer to Wire Rope Users Manual, section 9 and ANSI Standard B30.5 for guidelines covering the inspection, maintenance, repair, and replacement of wire rope. Worn, kinked, bird caged, fatigued or otherwise damaged wire rope must be removed immediately. Wire rope when properly installed, lubricated and employed, will give many hours of satisfactory use. Whereas, a new piece of wire rope can be immediately ruined if misused.

Replace or repair any items found to be in unsatisfactory condition.

### Crushed Rope - Remove At Once!



**Kinked Rope - Remove at Once**

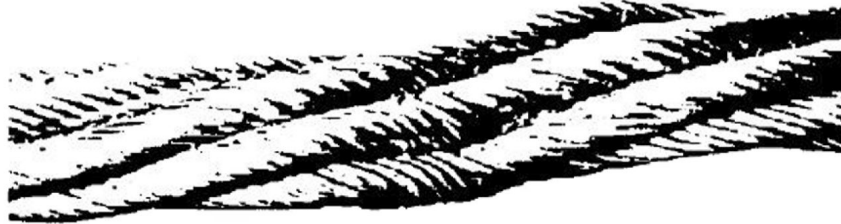

**Bird Caging - Remove at Once**

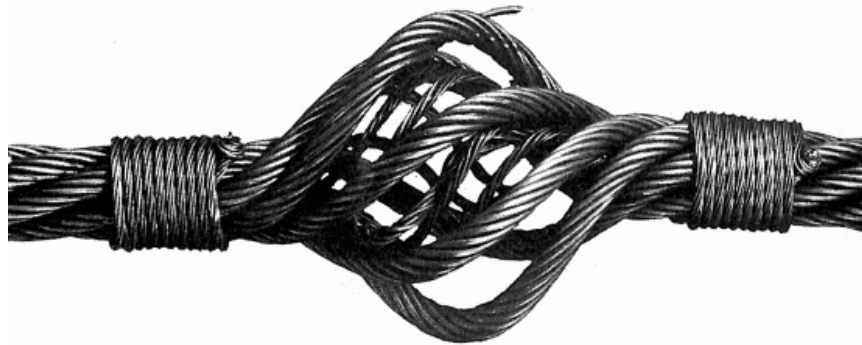

In addition to damage such as kinking, crushing and broken wires, factors such as corrosion, abrasion, pitting, peening and scrubbing of the outside wires, reduction of rope diameter, the condition of other components and proper lubrication are considered. Refer to [Wire Rope Lubrication](#) methods for wire rope lubricating procedures.

Before installing a new or replacement rope, make certain the rope to be used is the proper type and size. The wrong rope will not function properly and may even be dangerous.

Although other types of rope will function with the **Load King** crane, **Load King** recommends the use of rotation resistant rope on the 50-155 crane. Before using other types of rope, consult **Load King** engineering via your service representative.



When rotation resistant rope is used, the working load shall not exceed 1/5<sup>th</sup> (20%) of the rated breaking strength. The retirement criteria shall be as follows: two broken wires in six rope diameters or four broken wires in thirty rope diameters.

## 50-155 M & U

Maintenance and Service

Winch Lubrication

### Winch Lubrication

#### Recommended Planetary Gear Oil

Field experience, supported by engineering endurance tests, indicates the use of the proper gear oil and a program of regular preventative maintenance will help provide extended gear train life and reliable hoist brake performance. The information below is intended to assist in determining which lubricant is best suited to your application.

Please refer to the winch manufacturer's documentation (included within the manual pack) for specific recommendations and specifications of the proper oil to use in the winch.



Failure to use the proper type and viscosity of planetary gear oil may contribute to intermittent brake clutch slippage which could result in property damage, severe personal injury or death.

Some gear lubricants contain large amounts of EP (extreme pressure) and anti-friction additives which may contribute to brake clutch slippage or damage to brake friction discs or seals. Oil viscosity with regard to ambient temperature is also critical to reliable brake clutch operation. Tests indicate that excessively heavy or thick gear oil may contribute to intermittent brake clutch slippage. Make certain that the gear oil viscosity used in the hoist is correct for the prevailing ambient temperature.

Unless otherwise specified, it is recommended that the gear oil be changed after the first (100) hours or two (2) months of machine operation, then every one thousand (1,000) hours or six (6) months, whichever occurs first. The gear oil should also be changed whenever the ambient temperature changes significantly and an oil from a different temperature range would be more appropriate.

A warm-up procedure is recommended at each startup and is essential at ambient temperatures below +40°F (4°C).

The prime mover should be run at its lowest recommended RPM with the hydraulic hoist control valve in neutral allowing sufficient time to warm up the system. The hoist should then be operated at low speeds. Raise and lower, several times to prime all lines with warm hydraulic oil and to circulate gear lubricant through the planetary gear sets.



Failure to properly warm up the hoist, particularly under low ambient temperature conditions, may result in temporary brake slippage due to high back pressures attempting to release the brake, which could result in property damage, severe personal injury or death.

## 50-155 M & U

Maintenance and Service  
Wire Rope Lubrication

### Wire Rope Lubrication

New wire rope is lubricated during manufacturing, but this lubrication is only adequate for initial storage and the early stage of operation. To prevent the damaging effects of corrosion and to reduce wear, the wire rope must be lubricated at regular intervals.

The lubrication interval and the type of lubricant to be used depend on the type of wire rope, the severity of duty, and the type of corrosive elements the wire rope is subjected to. General guidelines are printed in the maintenance manual. Contact your **Load King** distributor for specific lubrication recommendations.

The wire rope must be properly protected at all times; therefore, the gaps between the strands and wires must be filled with lubricant to provide a complete seal. This manual covers the more commonly used methods of lubricating cable (wire rope). For special cable lubrication problems consult the cable manufacturer.

#### Hot Application

A heated bath is placed in the path of the wire rope, and the rope is passed through the hot lubrication over sheaves and a center guide wheel. Hot oils or greases have excellent penetrating qualities and upon cooling have high adhesive and film strength around each wire.

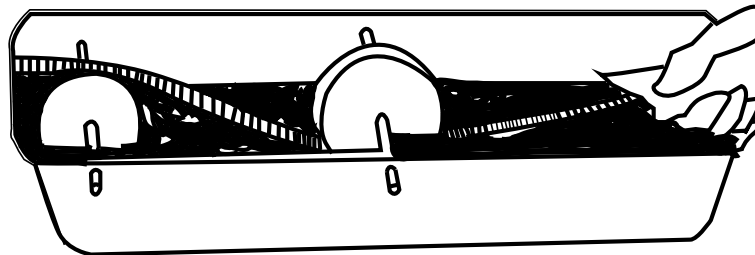

#### Continuous Bath

Run an operating rope through a specially constructed casing that has been packed with swabbing and loaded with lubricant. This affords continuous lubrication.

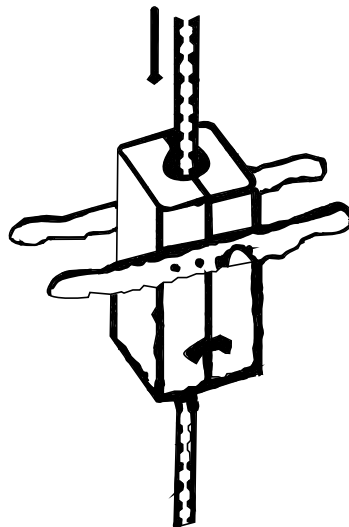

## 50-155 M & U

### Maintenance and Service Wire Rope Lubrication

#### Dripping

A container can be placed above the sheave, so that the rope can be lubricated by opening a spigot. Sheaves are the best location for lubricating operating wire ropes, because the wires and strands open somewhat as they bend along the groove.

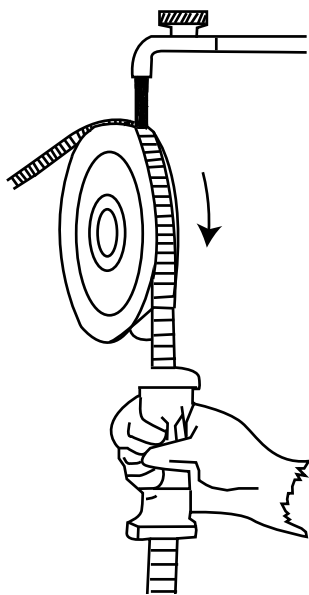

#### Pouring

Lubricant can be poured on. The rope should be lightly loaded and run slowly while being lubricated.

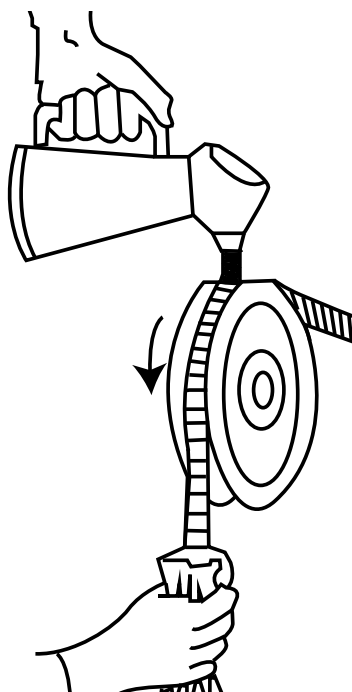

### Swabbing and Painting

Lubricant can be swabbed on with rags, or painted on with a brush. Both are quick methods which can be made part of the operating routine.

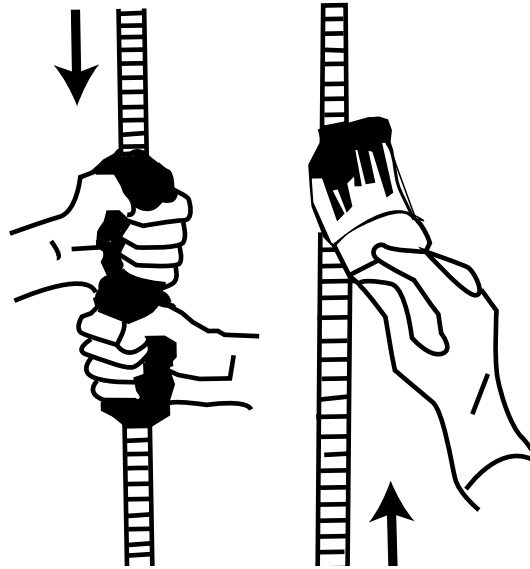

### Spraying

A light lubricant containing solvents can be applied to a wire rope by a properly directed spray nozzle.

### Aerosol Spraying

Installations requiring only small amounts of lubricants, or only occasional applications, may find the new aerosol cans of lubricant useful. They are available from your **Load King** parts department.

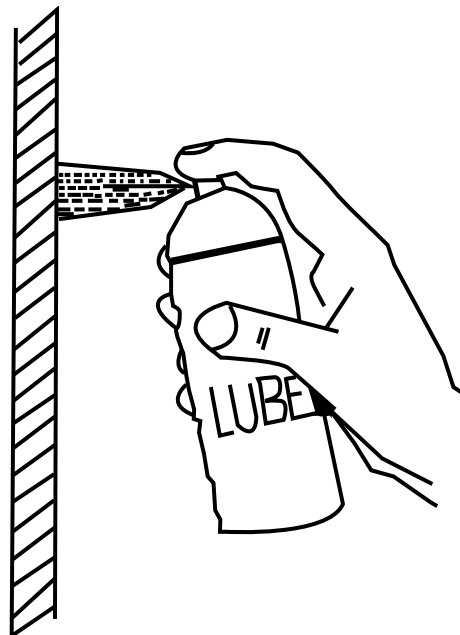

## 50-155 M & U

Maintenance and Service  
Anti-Two-Block System

### Anti-Two-Block System

#### Maintenance

This crane is equipped with an anti-two-blocking (ATB) system for both main boom head and jib. This ATB system sounds a horn (when in the **ON** position) and lights a light when a two-blocking condition is imminent. The system will also electrically disconnect the circuit for winching up, boom lowering or extending the boom in the event of an imminent two-blocking condition. Verify that the two-blocking system is functioning properly by performing the following procedure:

Check ATB switch(es) and freedom of chain-hung counterweight (item 6) as shown on main boom head in graphic below or in similar application on jib. Check the plug and socket connections at the boom head and on the jib, if deployed and reeved, for connection. The jib connector must be plugged into the boom head receptacle. Check system indicators and shut-off by manually lifting the chain-hung counterweight(s). If the ATB system is activated, a warning light will come on, the horn will sound, and the shut-off system will disconnect the controls. Check the entire length of cable and the cable reel for evidence of damage. Ensure the spring-loaded cable reel has spring tension and is free to rotate. Check the cab control unit. If the crane is equipped with control linkage disconnect, perform the following additional checks.

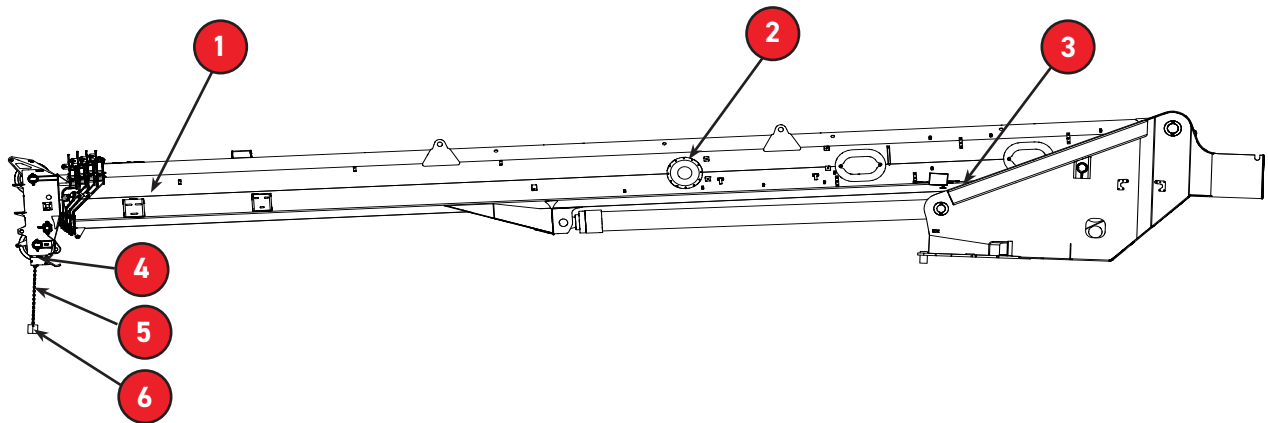

1.	2-Block Wire (External)
2.	2-Block Reel
3.	2-Block Wire (Internal Wireless Optional)
4.	2-Block Switch
5.	2-Block Chain
6.	2-Block Weight

1. With the engine **OFF**, check that free action (no self-centering) occurs on the boom lowering, the boom telescope lever-extended direction, and the winch levers - raising direction.
2. With the engine **ON**, ensure that these controls latch (remain in the neutral position) and provide a normal centering action.



This may require lowering the hook block away from the trip mechanism at the boom head to enable the latching of controls.

## Machine Storage

Machines being placed in storage must be adequately protected from deterioration during the period of idleness. This will ensure that they can be restored to active service with a minimum effort.

Before removing this hydraulic crane from service for extended periods, it should be prepared for storage as prescribed in the following paragraphs. In general, three (3) major components must undergo preparation. These are the machine proper, the engine and the transmission. The specific procedure to be followed depends upon the expected period of storage.

### Short Term Storage - 30 Days or Less

The machine should be thoroughly cleaned, lubricated in accordance with the [Master Lubrication Chart](#), and painted surfaces retouched where the paint has deteriorated. Exposed portions of all hydraulic cylinders should be coated with multi-purpose grease. Coat unpainted metal surfaces with multi-purpose grease after removing any rust accumulations.

### Long Term Storage - 30 Days or More

Long term storage requires greater preparation than short term storage and must be undertaken with greater care. The machine should be prepared as follows:

1. Perform the short-term machine storage preparation, making certain that all points with grease fittings are liberally lubricated.
2. Drain and refill the swing reducer, winch(es), axle differentials, planetary hubs and the hydraulic reservoir. Refer to [Hydraulic System Maintenance](#) when servicing the reservoir.
3. Distribute the new hydraulic fluid to all parts of the system by operating all functions.
4. Clean and tape the battery cables after removing and storing the battery.
5. Coat the external ring gear of the swing bearing with open gear lubricant or multi-purpose grease .
6. Block wheels so that rubber tires are not in contact with concrete. Cover tires if exposed to sunlight.
7. Fill the hydraulic reservoir to the top after the machine is parked in its storage spot.
8. Coat wire rope with lubricant.
9. Coat exposed cylinder rods with **CRC SP-400 Corrosion Inhibitor**. (This can be removed later with **CRC HD Degreaser**).

## 50-155 M & U

Maintenance and Service  
Machine Storage

### Chrome Cylinder Rod Storage

Hard chrome plating is primarily applied to steel cylinder rods for its wear resistant properties, although it does provide considerable corrosion resistance as well. Once the chrome-plated rod is assembled into a cylinder and put into service, the hydraulic fluid on the surface of the rod provides all the corrosion resistance required for the rod during its life cycle. As a cylinder cycles, hydraulic fluid is driven into any surface cracks that exist in the chrome plate. When these cracks are filled with hydraulic fluid, moisture or corrosive fluids cannot penetrate the cracks. However, some machining and cleaning operations can negatively impact the future corrosion resistance of chrome-plated shafting. For example, additives such as chlorine, sulfur, and sodium found in Extreme Pressure (EP) coolants and some washing solutions are known to accelerate and can strip chrome plating from the base metal. Cleaning processes such as phosphate washing are known to be detrimental to the corrosion resistance of hard chrome plated shafting.

If the rod is not periodically cycled and is subject to a corrosive environment, moisture and oxygen can work down through the chrome layer and begin to corrode the base metal. New equipment may be stored outside for a considerable period of time at the equipment dealership before it is sold. During these times, a protective barrier must be applied to the exposed cylinder rod. This protective barrier will preserve the integrity of the chrome plating by preventing the elements of corrosion from getting to the metal substrate.

If at all possible, cylinders should be stored in the retracted position. The steps outlined below cover the procedures to be followed for protecting new equipment from corrosion if it must be stored in the extended position:

1. Position the equipment as it will be stored and identify all the exposed portions of the chrome plated cylinder rods.
2. Clean any dirt and dust from the exposed portions of the cylinder rods using a dry cloth or a cloth which has been dampened with an appropriate solvent. Do not use caustics or acids.
3. Apply a thin coating of **Ferro-Kote 5856-BF**<sup>1</sup> to the exposed surfaces of the chrome plated cylinder rods. The Ferro-Kote may be thinned using a 40% Kerosene or No. 1 fuel oil mixture.
4. Inspect the cylinder rod surfaces and reapply at three to six month intervals.
5. If the equipment is to be moved and then stored again for an extended period of time, or if the cylinder is cycled; steps 1 through 4 should be repeated for all cylinder rods that were exposed.

For the protection of older equipment that is to be stored, the procedure outlined above can be used, but greater attention to cleaning the exposed portions of each cylinder rod is required. Solvent applied with plastic or copper wool can be used, but abrasives such as sandpaper should never be used to clean the exposed surfaces of the cylinder rod. If surface damage to the chrome plate is discovered, the frequency of corrosion barrier applications should be increased.



Caution must be used when cleaning equipment in service with high pressure washes. Soaps or chemicals containing chlorines or other corrosive elements should be avoided. Cylinders should be cleaned in a retracted position as not to expose rods to the chemicals. Cylinders should be cycled immediately following the wash. If rods are to be stored in the extended position, refer to steps 1-4 above.

<sup>1</sup> Ferro-Kote 5856-BF is a product of Quaker Chemical Company, Conshohocken, PA 19428

## 50-155 M & U

Maintenance and Service  
Restoration of Machine to Service



### Restoration of Machine to Service

Remove the machine from storage via the following procedure:

1. Remove the preservative lubricants from all surfaces.
2. Check all fluid levels, adding or draining as required.
3. Lubricate the machine according to the [Master Lubrication Chart](#), making certain that all points with grease fittings are lubricated.
4. Make a thorough visual inspection of the entire machine, placing special emphasis on the condition of all hydraulic hoses.

## 50-155 M & U

Maintenance and Service  
Outrigger Position Sensors

### Outrigger Position Sensors

The **Load King** 50-155 crane is equipped with outrigger position sensors. Each outrigger beam has two (2) proximity sensors for determining the location of outrigger beams at retracted position and full extension. There is one (1) proximity sensor located at the pivot pin area of each beam swing cylinder. This sensor detects full beam swing out position. Each sensor has an air gap to maintain to operate properly and send signals to the Load Moment Indicator (LMI). Visually inspect sensors for damage, the condition of wiring harness connections, and dirt/debris that could inhibit the sensor signal or proper air gap.

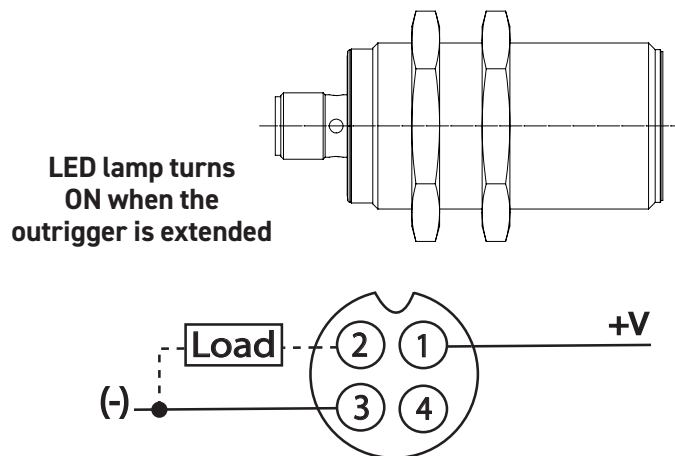

Sensor Characteristics and Setting	
Output Type	Normally Closed
Sensing Range	15 mm
Minimum Operating Voltage	6 VDC
Maximum Operating Voltage	48 V
Minimum Operating Temperature	-40C
Maximum Operating Temperature	+70C
Minimum Load Current	200 MA
Air Gap Setting	0.12" (3.2 mm)

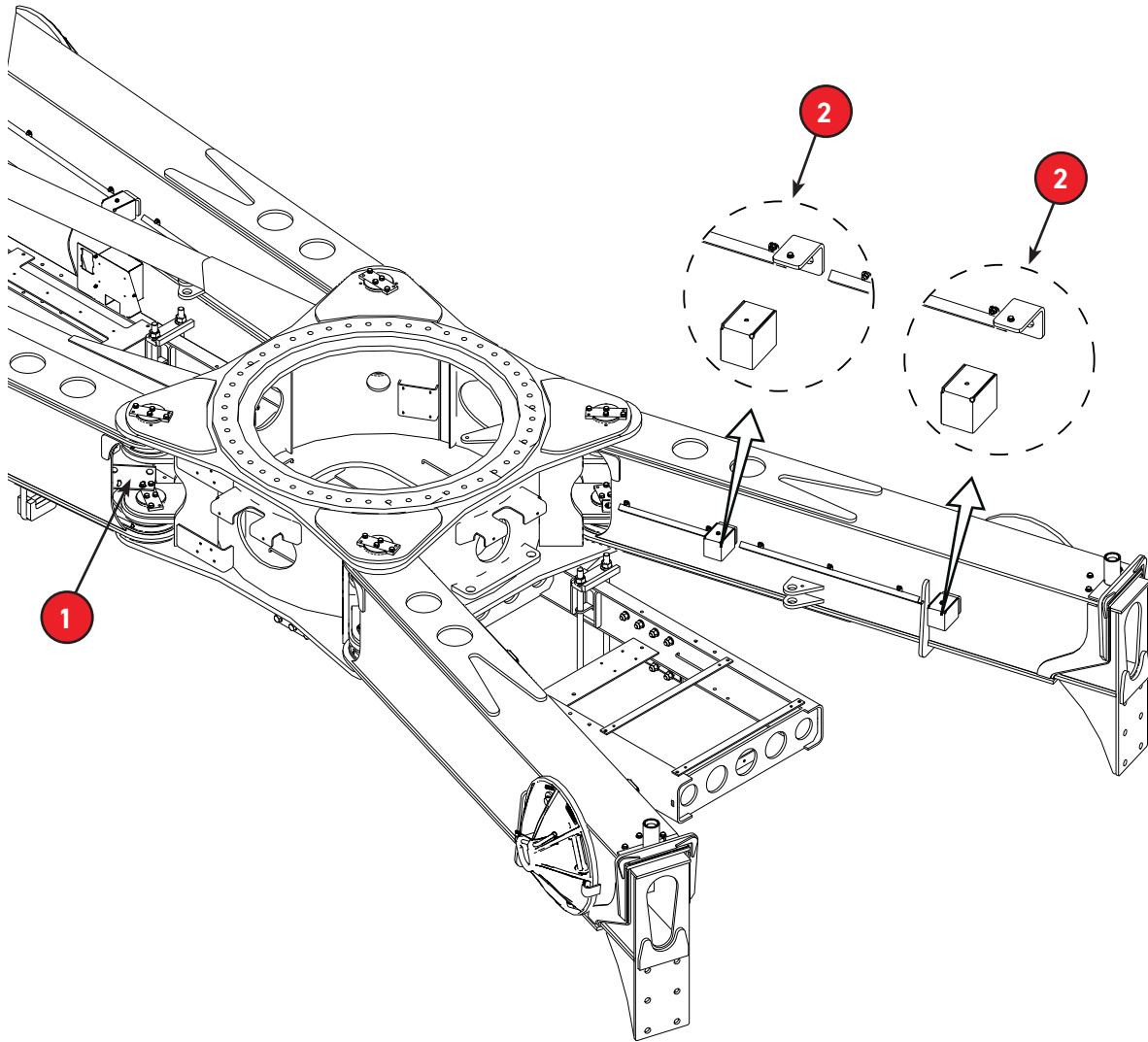

1. Proximity Sensor - Outrigger
2. Proximity Sensor - Outrigger Beam (Extended/Retracted)

## 50-155 M & U

Maintenance and Service  
Torque Wrench Extensions

### Torque Wrench Extensions

In some applications, a standard torque wrench and socket cannot be fitted to the bolt(s) to be tightened because of restricted access. In other instances, the torque value specified cannot be obtained because sufficient force cannot be applied to the standard length wrench. Both of these problems may be solved by the use of appropriate torque wrench extensions - either commercially made or fabricated by the user.

When using an torque wrench extension, keep in mind that the torque wrench (the actual torque reading or setting of the wrench) and the wrench force (the force applied to the wrench) must be adjusted to compensate for the added length and produce the desired bolt torque.

Refer to the illustration and formula below when calculating the proper adjusted values for torque wrench, wrench force, and bolt torque.

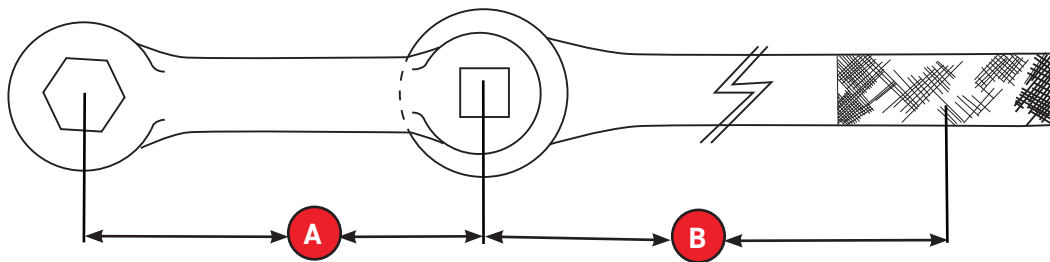

Torque wrench setting (TWS) at length "B" would be same as torque specified for cap screws not requiring use of an adapter.

#### Formula

$$\text{Torque Wrench Setting} = \frac{[(600 \text{ ft. lb.}) \times \mathbf{B}]}{(\mathbf{A} + \mathbf{B})}$$

Example: Assuming **A** = 10.25 in.  
Assuming **B** = 43 in.

$$\text{Torque Wrench Setting} = \frac{[(600 \text{ ft. lb.}) \times \mathbf{43 \text{ in.}}]}{(\mathbf{10.25 \text{ in.}} + \mathbf{43 \text{ in.}})}$$

$$\text{Torque Wrench Setting} = \frac{25,800 \text{ ft. lb.} \times \cancel{\text{in.}}}{\mathbf{53.25 \text{ in.}}}$$

$$\text{Torque Wrench Setting} = 485 \text{ ft. lb.}$$

## Hydraulic System

### Pressure Settings - Pumps and Valves

Setting hydraulic pressure is a complex operation and should be performed only after satisfying the following conditions:

1. Warm the hydraulic oil to greater than 80° F.
2. Always check pressure settings at maximum engine speed in PTO mode.
3. Make sure that the pressure gauge is calibrated. If the gauge is subjected to pulsing pressure for a few seconds, the calibration may be lost. The gauge must have a proper snubber to read center of pump pressure ripple or erroneous readings will result.

### Maintenance Checks

All relief valve maintenance checks should be performed on a semiannual basis. The relief valves used on this hydraulic crane have a screw type adjustment. If it is determined that the valve is out of adjustment, follow this general adjustment procedure:

#### Pump Adjustment

Check and adjust the standby pressure. Refer to **Boom Valve - Figure 1**.

#### Boom Hoist and Winch Main Pressure Setting Procedure

Check the boom relief settings as follows:

1. Operate the boom over relief to warm the oil if necessary.
2. Attach a calibrated pressure gauge to the test port on the inlet pressure port at the valve bank.
3. Raise the boom completely and continue to boom up with the engine running at full governed RPM. The gauge reading at location (3) should be 4500 psi. Adjust the Load Sense (LS) (5) pressure adjustment screw as needed according to the Pressure Settings table following. Refer to **Boom Valve - Figure 1**.
4. Lower boom completely and continue to boom down with the engine running at full governed RPM. The gauge reading at location (3) should be 725 psi. Adjust the Load Sense (LS) (5) pressure adjustment screw as needed according to the Pressure Settings table following. Refer to **Boom Valve - Figure 1**.

#### Extend/Retract Reliefs

The initial range has been preset. If adjustment is necessary, it is accomplished by loosening the jam nut and either turning the adjustment screw (1) or (6) to increase pressure or backing it off to lower pressure. Re-tighten the jam nut when the desired pressure is obtained. Refer to **Boom Valve - Figure 1**.

Set **EXTEND** pressure by the following procedure:

1. Extend the boom completely and continue to extend the boom over relief with the engine running at full governed RPM. Initially, set the extend port relief valve (6) to obtain a reading of 3500 psi. Refer to **Boom Valve - Figure 1**.

## 50-155 M & U

### Maintenance and Service Hydraulic System

Set **RETRACT** pressure by the following procedure:

- Retract the boom completely and continue to retract over relief with the engine running at full governed RPM. Initially, set the retract port relief valve (1) to obtain a reading of 3500 psi. Refer to **Boom Valve - Figure 1**.

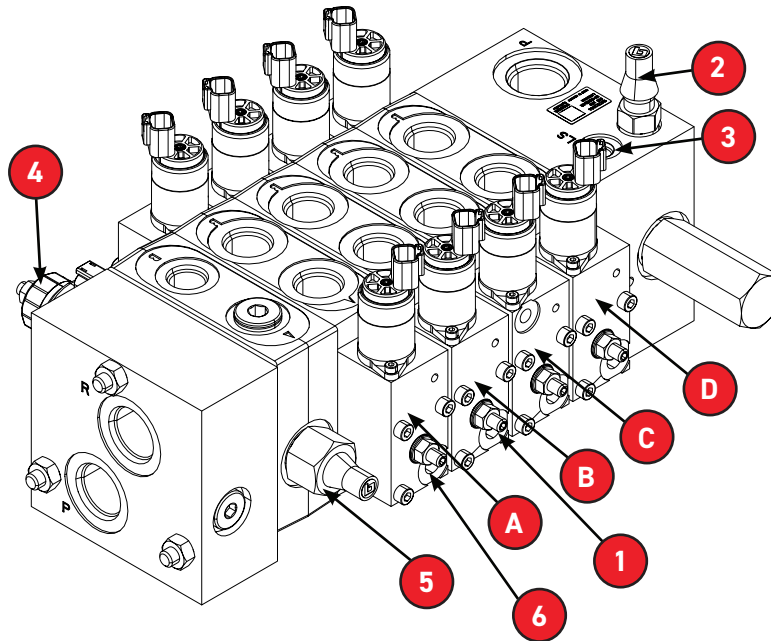

**Boom Valve - Figure 1**

Boom Valve Functions and Adjustments		
Item	Function	Notes
A	Hoist	Valve Section
B	Telescope	Valve Section
C	Main Winch	Valve Section
D	Aux Winch	Valve Section
1	Relief Valve	Telescope in circuit - Limits pressure for port (B) Retract
2	Pump Pressure	Gauge port to measure pump pressure
3	Pilot Pressure	Set to 400 psi (28 bar) -requires installation of a pressure tap, and only adjusted or checked by <b>Load King</b> authorized service
4	Main Relief	Refer Main Relief Setting of Boom Valve Pressure Settings table
5	Load Sense Pressure Adjustment	Refer to Load Sense (LS) settings of Boom Valve Pressure Settings table
6	Relief Valve	Telescope (A) Circuit - Extend

**50-155 M & U**Maintenance and Service  
Hydraulic System

50-155 Pressure Settings					
Piston Pumps and Boom Valve					
Description	Type	Bar	PSI	Comments	Notes
Piston Pump	Standby Pressure (Margin)	28	406	Main Boom Functions	Set pressure to 406 psi (28 bar). Measure pressure at MP or MP1 in boom valve inlet section.
Boom Valve	Load Sense (LS)	310	4500		The LS adjustment is on the inlet section of the boom valve.  Measure pressure at MXL or MXL1 in boom valve inlet section.
System Pressure Check	System Pressure	341	4950	Maximum System Pressure	This reading is the result of LS pressure plus margin and is read at MP or MP1 on the boom valve inlet section. The max reading equals the compensator setting.
Piston Pump	Pressure Compensator (PC)	317	4600		The larger adjusting screw on the pump, sets the compensator pressure limit. Read at MP or MP1.
Boom Valve	Main Relief	324	4700	Clipper Relief	Must increase the PC setting on the pump and the LS pressure to set the main relief setting. The main relief setting is located on the inlet section of the boom valve. Once the main relief has been set, return the PC to the proper setting and then set the LS pressure (LS + Margin = System Pressure).
Boom Valve	Tele- Extend	241	3500	Limits Boom Extend Pressure	Check pressure by fully extending boom until 2 tele cylinder is bottomed out.
Boom Valve	Tele- Retract	241	3500	Limits Boom Retract Pressure	Check pressure by fully retracting boom until cylinder is bottomed out.
Boom Valve	Boom Down	50	725	Limits Boom Down Pressure	Check pressure by lowering boom until the cylinder is bottomed out.
Diverter Valve	Outrigger Swing	172 200	2500 2900		To set the outrigger relief pressure setting, the outrigger jack or beam must be fully extended or retracted at full engine RPM.  Check swing relief by tilting cab up.

## 50-155 M & U

Maintenance and Service  
Hydraulic System

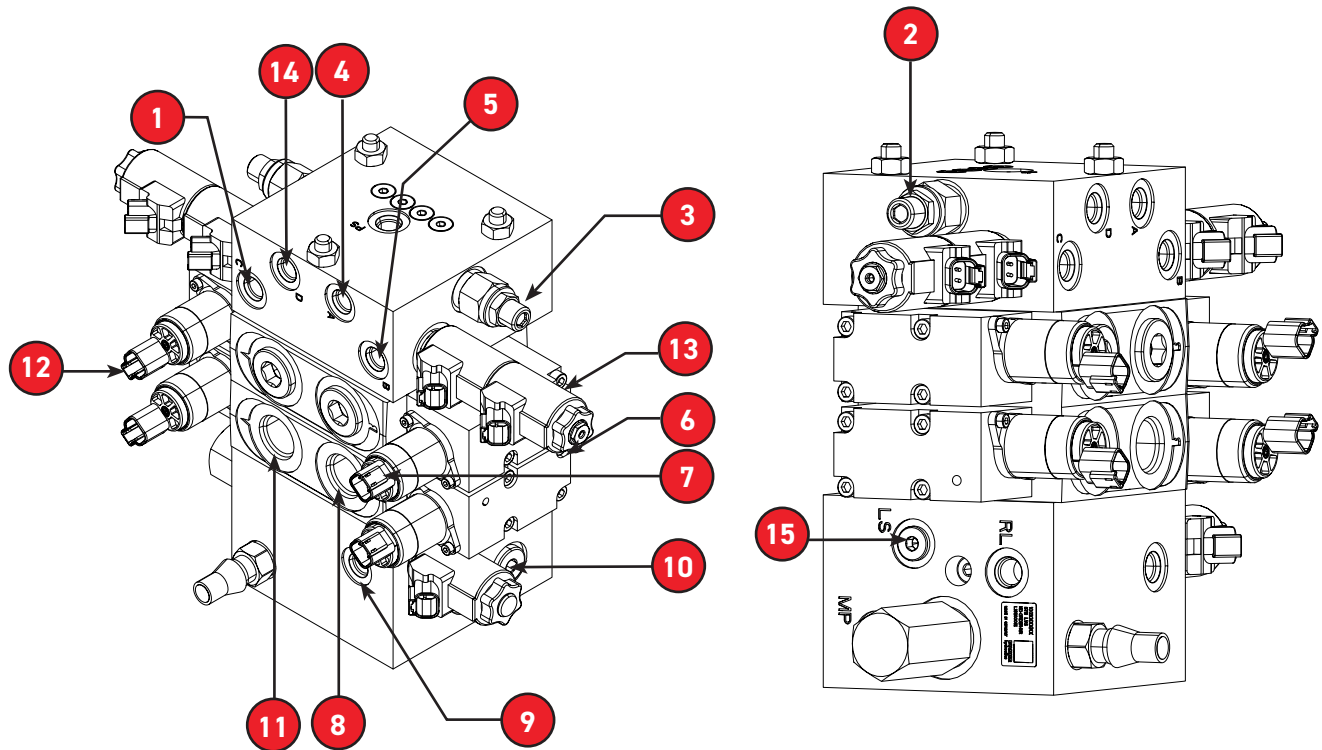

Swing Valve - Figure 2

No.	Function	Pressure Setting (PSI)
1	Cab Tilt Up	N/A
2	Cab Tilt Counterbalance	1000 psi (70 bar)
3	Counterweight Counterbalance	2600 psi (179 bar)
4	Counterweight Lift	N/A
5	Counterweight Lower	N/A
6	Jib B	N/A
7	Swing Brake B	N/A
8	Swing B	N/A
9	Park Brake	N/A
10	Load Sense Relief Valve	2900 psi (200 bar)
11	Swing A	N/A
12	Swing Brake A	N/A
13	Jib A	N/A
14	Cab Tilt Down	N/A
15	LS Port	N/A

## Swing Relief

Check the swing relief using the following procedure:



Prior to checking the swing relief valve pressure setting the main Diverter Valve relief must be set to the proper pressure of 3500 psi.

1. Operate the machine to warm the oil if necessary.
2. Connect a calibrated pressure gauge to the test port (15), refer to **Swing Valve - Figure 2**.



Test port (15) is located on the Swing Relief Valve which is mounted inside the superstructure just to the left of the swing reduction unit. The relief valve is set to 2900 psi with cab tilt bottomed out.

Lower the cab tilt by actuating rocker switch located on the right armrest until the cab tilt hydraulic cylinder bottoms out. Continue to lower the cab tilt and read pressure on the gauge at LS port (15), refer to **Swing Valve - Figure 2**.

## Swing Maximum Operating Pressure Adjustment

Set the swing valves relief pressure to 2900 psi by adjusting item (10) with a gauge in LS port of the swing valve and cab tilt port, refer to **Swing Valve - Figure 2**.

## Outrigger Relief Adjustment

Install 5000 psi test gauge in MLS port of diverter valve and set outrigger relief valve to 2500 psi.

## 50-155 M & U

Maintenance and Service  
Hydraulic System

### Main Relief in Diverter Valve Adjustment

If main relief in diverter valve needs to be adjusted, use the 5000 psi test gauge and proceed as follows:

1. Connect the gauge at the quick disconnect in the diverter valve at G port (3), located on the left side of the front outrigger box, refer to **Diverter Valve - Figure 3**.
2. Start the engine and run at full throttle.
3. The maximum operating pressure at cab tilt (2) is set at 2900 psi, refer to **Swing Valve - Figure 2**. This pressure must be increased above 3500 psi to set the main relief (2), refer to **Diverter Valve - Figure 3**.
4. Move cab tilt up to read maximum pressure setting.
5. If necessary, adjust the main relief (2) to 3500 psi, refer to **Diverter Valve - Figure 3**.
6. Reset the maximum operating pressure at relief valve (10) to 2900 psi, refer to **Swing Valve - Figure 2**.

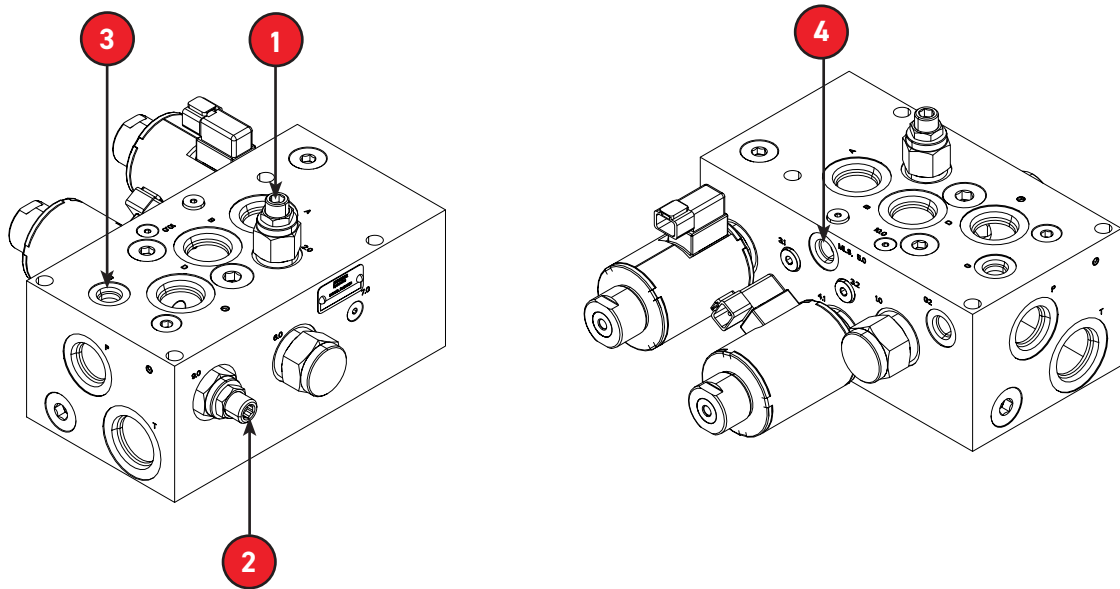

Diverter Valve - Figure 3

1. Outrigger relief valve (pre-set to 2500 psi).
2. Main relief (pre-set to 3500 psi).



The gauge port for outrigger pressure is MLS (4). The gauge port for pump pressure is G (3), refer to **Diverter Valve - Figure 3**.

## Pumps

### General Instructions

This machine is equipped with a tandem pump, which is piggybacked on a single pump.

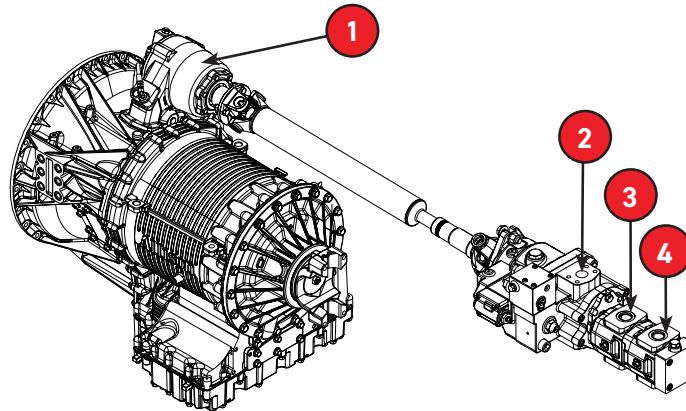

**Allison Transmission**

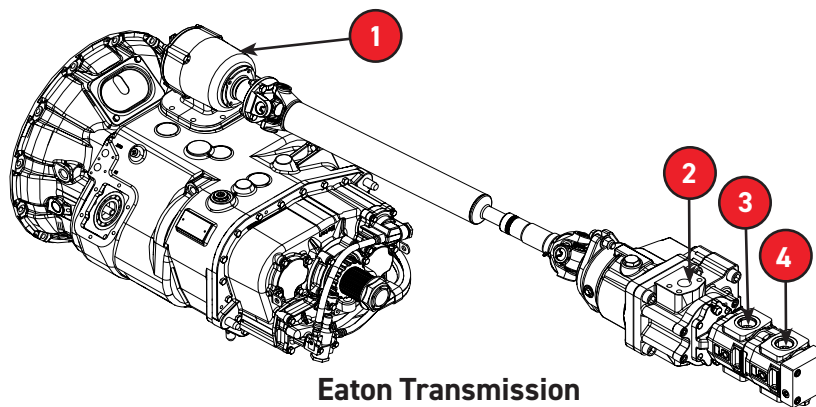

**Eaton Transmission**

1. PTO
2. Piston Pump - Hydraulics (Boom Functions)
3. Gear Pump - Outriggers and Swing
4. Gear Pump - HVAC

In the event of pump failure, it is recommended to contact your **Load King** distributor. However, should you decide to facilitate the repair of these units - consult the manufacturer's repair manual - read all of the steps used in disassembly and reassembling the unit prior to working on the unit.

Dirt particles can impact the performance of the hydraulic system. Proper maintenance of hydraulic equipment relies on a clean work environment. Make sure that any hydraulic parts are disassembled and reassembled in a clean area. It is important to air blast all parts and wipe them with a clean, lint-free cloth before assembly.

Use caution in gripping all parts in the vise to avoid damaging machined surfaces.

A pump must be driven in the direction of rotation for which it was built; otherwise pressure will blow the shaft seal. Check for proper direction of rotation before turning the pump.

## 50-155 M & U

Maintenance and Service  
Rotation System

### Rotation System

#### Inspection of Rotation Bearing Clearance

- It is not feasible to make an analysis of the condition of the rotation gear while it is on the unit. There are too many variables involved for this to be accurate.
- A bearing may cause a problem in the operation of the Boom Truck or the confidence of the Operator long before it would be deemed structurally unsafe.

To properly check the radial clearance of the rotation gear, it must first be removed from the Boom Truck and placed on a heavy flat table. Remove all dirt and grease from the outside of the gear and secure it to the table with clamps, assuring that the inner raceway rotates freely after clamping it to the table.

As shown in the figure below, attach a large C-clamp in position (1), and tighten just enough to take all the slack out of the raceway. Install a dial indicator as close to position (1) as possible, and set it to "0".

Remove the C-clamp and attach at clamp position (2). Again, tighten just enough to take up the slack in the two raceways. Look at the dial indicator, noting the amount of change in the reading. This measurement is the radial clearance of the bearing.

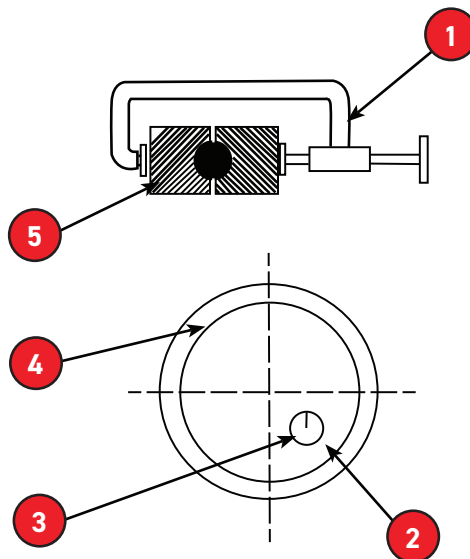

**Radial Clearance Check Procedure**

1. Clamp Position (1)
2. C-clamp
3. Dial Indicator
4. Clamp Position (2)
5. Rotation Gear

The following bearing clearances should be observed:

- Any new bearing being installed on a **Load King** boom truck should not have more than 0.004 - 0.007 radial clearance.
- Any bearing removed from a unit that has a radial clearance of 0.030 to 0.050 should be thoroughly screened for roughness while rotating. If excessively rough, the bearing should be disassembled and thoroughly inspected for damage in the raceways, and for rust or pitting.

## Electrical System

### Fuse Block-Operator's Cab

The Operator's cab fuse block is located above the right hand console, and requires periodic inspection. If there are issues detected with any of the circuits listed in the chart description below, checking the respective fuses and relays, and then replacing any defective components are some of the easiest troubleshooting steps. If a fuse or relay fails, this will be shown of the Fuse and Relay Status screen, detailing the component to be replaced.



Only replace fuses and relays with those of the same voltage/amperage rating. Replacing fuses and/or relays with improper ratings may cause damage to electrical systems.

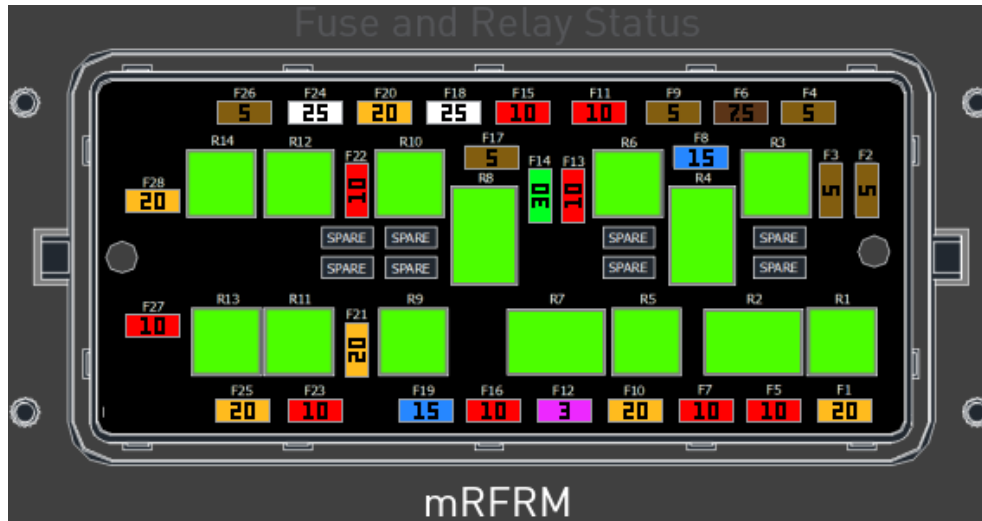

Current Rating (A)	Housing Color
5	Orange
7.5	Light Brown
10	Red
15	Blue
20	Yellow
25	White
30	Green

Relays	
R1	Spotlight (F1)
R2	Roof Wiper Low (F7)
R3	Roof Wash Pump (F4)
R4	Roof Wiper High (F8)
R5	Front Cab Work Lights (F10)
R6	Front Wash Pump (F9)
R7	Spare (F16)
R8	Engine Start (F17)
R9	Beacon (F19)
R10	Front Wiper Low Speed (F18)
R11	Horn (F23)
R12	Front Wiper High Speed (F24)
R13	Top Cab Work Lights (F25)
R14	Engine Stop (F26)

## 50-155 M & U

Maintenance and Service  
Fuse Block-Operator's Cab

Fuse No.	Rating in Amps	Function
1	20 A	Spotlight (Relay 1)
2	5 A	Acc Power to Lower
3	5 A	Spare
4	5 A	Roof Wash Pump (Relay 3)
5	10 A	Spare
6	7.5 A	Seat Heater
7	10 A	Roof Wiper Low (Relay 2)
8	15 A	Roof Wiper High (Relay 4)
9	5 A	Front Wash Pump (Relay 6)
10	20 A	Front Cab Work Lights (Relay 5)
11	10 A	Defrost Actuator
12	3 A	Dome Light
13	10 A	Radio
14	30 A	HVAC Blower Fan
15	10 A	Controls & Joysticks
16	10 A	Spare (Relay 7)
17	5 A	Engine Start (Relay 8)
18	25 A	Front Wiper Low Spd (Relay 10)
19	15 A	Beacon (Relay 9)
20	20 A	Spare
21	20 A	Power Outlets
22	10 A	Radio Receiver & Camera
23	10 A	Horn (Relay 11)
24	25 A	Front Wiper High Spd (Relay 12)
25	20 A	Top Cab Work Lights (Relay13)
26	5 A	Engine Stop (Relay 14)
27	10 A	Spare
28	20 A	Greer LMI Module

## Relay and Fuse Block-Chassis

The chassis relay and fuse block is under the decking access lid, near the boom rack, and requires periodic inspection. If there are issues detected with one of the circuits listed in the chart below, checking the respective fuses and relays, and then replacing any defective components are some of the easiest troubleshooting steps.



Only replace fuses and relays with those of the same voltage/ampere rating. Replacing fuses and/or relays with improper ratings may cause damage to electrical systems.

ID	Amp Rating (Fuse)	Description
R1	Relay - 12 VDC	Sensor Power Relay
R2	Relay - 12 VDC	Diverter Relay
R3	Relay - 12 VDC	Cooler Control Relay 2
R4	Relay - 12 VDC	Cooler Control Relay
F1	30A	Oil Cooler Fan 2
F2	15A	Outrigger Controls
F3	30A	Oil Cooler Fan 1
F3	25A	SS Power
F5	25A	SS Power
F6	25A	SS Power

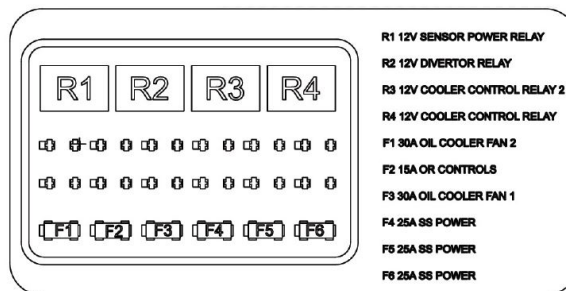
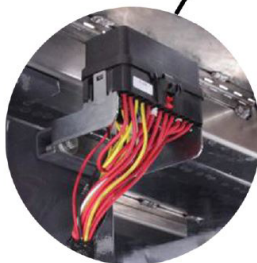
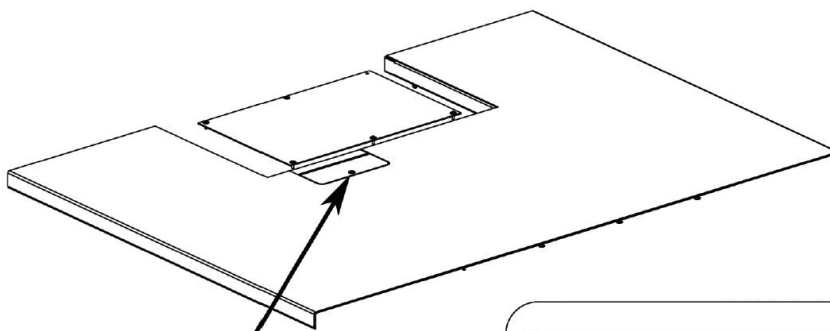

## 50-155 M & U

Maintenance and Service

Electrical System Collector Ring

### Electrical System Collector Ring

When troubleshooting the electrical system, always check the collector ring first to see that spring loaded brushes are centered in the bands. Keep these bands free of any foreign material.

Keep the set screws on the collector ring frame tight. Otherwise, the wire harness may wrap up as the machine is swung.

The cover should allow for free operation of the collector ring and the brake. If linkages bind, erratic operation may result. Check for unrestricted operation.

### Collector Ring Maintenance and Service

If not revolved for a while, under some conditions the ring will have a tendency to collect fine silt, or a salt atmosphere can cause corrosion. If this happens, the crane should be rotated through several revolutions. The cleaning action of the brushes should clean the ring surfaces. If it does not, or it is not practical to revolve the machine, it may be necessary to use a standard non-residue solvent to clean the ring. Then lightly sand the brushes and rings with a fine grade of sandpaper and dust off with compressed air.

To replace a brush and arm assembly, remove the hex nuts and washers at the top of the brush stud along with the outboard bearing. This will allow the brush assemblies to be removed. Carefully remove the brushes without over-stretching the brush springs and arrange in order of removal with spacers. Replace the damaged brush assembly and then reassemble the brushes and spacers in the reverse order of removal. This will ensure the correct spacing between electrically live parts. Be sure that all brushes are snapped in tight and making full contact with their corresponding brass ring. Ensure that all springs are hooked correctly through the brush arm.



Special care should be exercised when handling or replacing the 7 1/2" amp brush and arm assemblies. Due to their small size, these assemblies can break easily if forced up or down. Breakage is extremely rare when the component is installed properly.

The collector ring has a nylon bearing in the base of the assembly, eliminating the need for lubrication.

If it should become necessary to remove the collector ring from the machine, do so by loosening the socket screws at the base of the ring. This will allow the ring to be lifted off the mounting tube. When replacing the collector ring, make sure these set screws are re-tightened. (Recommended torque values are 45-55 in-lbs). If the set screws are not tight, the core may turn or be held by the brushes, twisting off the core leads or center harness.

## 50-155 M & U

Maintenance and Service  
Electrical System Collector Ring



### Collector Ring-15 Circuit Identification Chart

Circuit	Color	Wire Tag	Function
1	Red	000TA	Battery
	Red	000TB	Battery
2	Red	000TC	Battery
	Black	000TD	Battery
3	Red	000TE	Battery
	Red	000TF	Battery
4	Black	016TB	Ground
	Black	016TC	Ground
5	White	015TA	Key Start
6	Red	017TA	Lower Ignition
7	Yellow	047TA	Ignition Switch Acc
8	Yellow	020TA	Engine Stop
9	White	500TA	Outrigger Position
10	White	501TA	Outrigger Position
11	Yellow	075TA	Marker Light
12	Yellow	J1939TA +	J1939 +
13	Green	J1939TA -	J1939 -
14	Yellow	CAN_12	Can High
15	Green	CAN_12	Can Low
	Red	CABLE 04	Potentiometer +V
	Black	CABLE 04	Potentiometer -V
	White	CABLE 04	Potentiometer Signal A
	Green	CABLE 04	Potentiometer Signal B
	Shield	SHIELD	Potentiometer Shield



The above circuit chart applies to **Load King** Stinger 50-155 series cranes. The collector ring circuits are self-cleaning. If the crane has been out of operation for a considerable amount of time, cleaning the copper brush circuits should be accomplished by rotating the upper structure 360 degrees 10-20 times. The collector ring is not internally serviceable. If the unit is defective, has broken terminals, or the brush circuits are not functional, contact the **Load King** Parts Department for a complete replacement collector ring.

## 50-155 M & U

Maintenance and Service

Maintenance-Free Battery Testing

### Maintenance-Free Battery Testing

#### Visual Inspection

Possible Cause	Remedy
Visible damage and/or terminal leakage.	Battery cannot be used. Replace battery.

**Electrolyte levels and state of charge note: Proceed directly to cause that applies.**

Possible Cause	Remedy
Electrolyte level at top of plates. Water cannot be added.	Replace battery.
If there is an indicator and it shows low level.	Replace battery.
Electrolyte level okay, unknown, or water can be added. Stabilized voltage below 12.4 volts.*	Add water if needed (if possible). Charge battery, then turn on high-beam head lamps (or 15 amp load for 15 seconds). Proceed to load test.
If there is an indicator and it shows low charge.	Charge battery, then turn on high-beam head lamps (or 15 amp load for 15 seconds). Proceed to load test.
Stabilized voltage above 12.4 volts* or indicator indicates charged.	Perform load test.

#### Load Test

Perform load test using the following procedure:

1. Connect voltmeter and ampere load equal to 1/2 cold cranking amperes @ 0°F (-18°C) rating of battery for 15 seconds.
2. Observe voltage at 15 seconds with load on.
3. Refer to voltage chart.

\* If the voltage remains below the voltage chart levels, replace the battery. If the voltage is equal to or above chart values, return the battery to service.

Voltage Chart		
Estimated Electrolyte Temperature		Minimum Required Voltage Under 15 Second Load
70°F	21°C and above	9.6
60°F	16°C	9.5
50°F	10°C	9.4
40°F	4°C	9.3
30°F	-1°C	9.1
20°F	-7°C	8.9
10°F	-12°C	8.7
0°F	-18°C	8.5

If water can be added to a battery, a hydrometer reading of 1.225 @ 80°F (27°C) can be used instead of the 12.4 Voltage reading.



**Battery Box Location - Under Left Side of Vehicle**

1	Diesel Exhaust Fluid (DEF) Fill Location
2	Battery Box

**PAGE INTENTIONALLY LEFT BLANK**

## Troubleshooting

### Introduction

A regular program of periodic preventive maintenance is essential to prolong crane operating life, maximize efficient service and minimize downtime. This section details a series of checks and procedures which are to be performed at daily, weekly, monthly and semiannual intervals. These intervals are stated both in terms of calendar periods and hours of operation.

The checks prescribed for longer intervals include all the checks required for the shorter intervals. Thus, the weekly check includes all items in the daily check, the monthly check includes weekly and daily checks, and so on through the semi-annual check, which includes the quarterly, monthly, weekly and daily checks.

A comprehensive checklist serves as a tool to help record preventive maintenance checks performed, problem areas identified, and maintenance requirements.

Check points are categorized as per the maintenance inspection intervals. Refer to the Maintenance and Service section, "[Maintenance Checks and Lubrication](#)".

This maintenance schedule is a guide which ensures that basic preventive maintenance requirements will be met under average operating conditions. Conditions which impose greater wear, loads, or strain on the crane may dictate reduced check intervals. Before altering the maintenance schedule, reevaluate crane operation and review the crane maintenance records. Consider all factors involved and develop a revised schedule adequate to meet routine maintenance requirements.



While performing periodic checks on the engine, always refer to the manufacturer's manual for maintenance requirements. The engine manufacturer's recommendations take precedence over this manual.

### Operator Observation

It is the responsibility of an Operator to notice and report any unusual sounds, odors, or other signs of abnormal performance that may indicate trouble ahead.

The following items should be checked on a regular basis before starting or while operating the crane.

- Visual Inspection - Check the complete machine for any unusual conditions.
- Check the hydraulic system for any leaks or damage.
- Check the engine compartment for the following:
  - Belts for tension and wear
  - Coolant level
  - Oil level
  - Transmission oil level
  - Air cleaner sight gauge
  - Air intake
  - Exhaust and Muffler
- Check for battery fluid leaks and proper fluid level

## 50-155 M & U

### Troubleshooting General Procedure

- Check the crane boom for the following:
  - Hook block for wear or damage
  - Two-block system for proper function
  - Cable and cable spooling on the winch
  - Cylinder pin connections for wear
- Check the tires, axles, and drive lines for wear or damage
- Check in the cab for:
  - Instruments functioning properly
  - Control operation
  - Glass for good visibility
  - Safety equipment is ready for use
  - All of the lights are operational
  - Cleanliness - free from mud and debris

### General Procedure

1. **Know the system:** Study the manual and learn what makes the machine “tick” as well as how it should behave, sound, and smell.
2. **Operate the machine:** Test and operate all machine functions. Note all abnormal sounds, odors, and movements. Always proceed in the most logical order to determine the cause.
3. **Inspect the machine:** Look for leaks, listen for the source of unusual sounds, and identify the source of unusual odors. Check the condition of the oil and filters.
4. **List the possible causes:** The Operator should use their best judgment in listing all possible causes of the failure.
5. **Reach a conclusion:** Review the list of possible causes and decide which ones are the most likely to cause the failure. Consider the most obvious first.
6. **Test the conclusion/resolution:** Test the conclusions in order of obviousness until the source of failure has been found. The machine can then be repaired with minimal downtime. Make the necessary repairs, then check again to ensure that nothing has been missed. Functionally test the repaired part in the system.
7. **Review maintenance procedures:** Prevent the recurrence of premature failures by checking the filters, temperature, adjustments, and lubrication on a regular basis. Conduct daily inspections.



Safety is always the number one consideration when working around cranes. Safety requires a thorough understanding of the job to be done as well as the use of common sense.

## Hydraulics - General

Before beginning any troubleshooting, become thoroughly acquainted with the two basic fundamental facts of a hydraulic system:

**Speed:** The speed of a hydraulic function is directly related to the system flow. A reduction in speed of a cylinder or motor is caused by an insufficient quantity of oil being delivered to the component.

**Power:** The power or force of a hydraulic function is related to pressure.

If the differences between speed and power of a hydraulic system are correctly understood, accurate troubleshooting can be accomplished in a short amount of time.



Do not resort to increasing the valve relief pressure in an attempt to fix any problem in the system. Fully diagnose the problem, rather than put increased pressure into the system that is lacking proper hydraulic flow.

Hydraulic components are precision units, and their continued smooth operation depends on proper care. Therefore, do not overlook hydraulic systems. Keep them clean and change the oil and oil filter at established intervals.

If in spite of these precautions, improper operation occurs, the cause can generally be traced to one of the following:

- Use of the wrong viscosity or type of oil.
- Insufficient fluid in the system.
- Presence of air in the system.
- Mechanical damage or structural failure.
- Internal or external leakage.
- Dirt, decomposed packing, water, sludge, rust, etc., in the system.
- Improper adjustments.
- The oil cooler is clogged, dirty, or leaking.

When disconnecting hydraulic fuel, lubricating oil lines, or air lines, clean the surrounding area as well as the point of disconnect. Cap, plug, or tape each line or opening as soon as it is disconnected to prevent the entry of foreign particles.



When access covers or inspection plates are removed, the same cleaning and covering recommendations apply.

All parts should be cleaned and inspected. Make sure that all passages and holes are open. Keep all parts clean by covering them.

When installing parts, make sure they are all clean. Keep new parts in their original packaging until they are ready for assembly. Before installing new parts, clean the preservative compound from all machined surfaces.

## 50-155 M & U

### Troubleshooting Swing Circuit

#### Swing Circuit

Cause	Remedy
<b>Swing Completely Inoperative</b>	
Mechanical swing lock applied, if equipped.	Disengage the swing lock.
Swing brake applied.	Disengage the swing brake.
Spring brake stuck in applied position.	Disassemble swing brake and free-up unit.
Swing valve main relief valve stuck in open position.	See section on "Relief Valves".
Internal leakage in the swing motor is excessive.	See section of "Fluid Motor".
Mechanical fault in swing reducer gearbox or swing bearing.	Repair swing reducer gearbox or replace swing bearing.
Hose plugged or liner collapsed.	Replace hose.
Rotary manifold leaking internally.	Reseal rotary manifold.
Faulty swing pump.	Replace swing pump. See section on "Pumps".
<b>Swing Motion Sluggish</b>	
Main relief valve stuck in open position.	Replace main relief valve.
Faulty swing pump.	Repair or replace swing pump.
Internal leakage in the swing motor is excessive.	Replace or reseal swing motor.
Leakage around swing control valve spool.	Replace or reseal swing control valve.
<b>Swing Motion Erratic</b>	
Swing brake and/or swing lock brake not releasing completely.	Check operation of swing brake and/or swing lock.
Low hydraulic oil level.	Add hydraulic oil as required.
Swing bearing not lubricated properly.	Lubricate swing bearing.
Main relief valve malfunctioning.	See section on "Relief Valves".

## Boom Hoist Circuit

Cause	Remedy
<b>Boom Drifts Down</b>	
Hold valve not seating properly.	Replace hold valve.
Hoist cylinder by-passing.	See section on " <a href="#">Cylinder Leakage</a> ".
<b>Boom Hoist Only - Inoperative or Erratic</b>	
Boom will drift down.	Repair or replace hold valve.
Boom won't lower.	Repair, replace, or backflush hold valve.
Boom hoist cylinder binding.	Repair or replace.
Load is too high.	Refer to capacity chart, check LMI.
Piston packings damaged.	Replace packings.
Low oil level.	Add oil as required.
Hose plugged or liner collapsed.	Replace hose.
Air in cylinder.	Bleed cylinder.
<b>Boom Drops Slightly as Raise Control is Released</b>	
Air in cylinder.	Bleed cylinder.
Boom hoist hold valve free flow check not seating properly.	Replace hold valve.
<b>Boom Hoist and Telescope Inoperative or Erratic</b>	
Pump disconnect not engaged.	Engage pump disconnect.
Main relief valve malfunctioning.	See section on " <a href="#">Relief Valves</a> ".
Low oil level.	Add oil as required.
Rotary manifold leaking internally.	Reset rotary manifold.
Piston pump faulty.	See section on " <a href="#">Pumps</a> ".

## 50-155 M & U

Troubleshooting  
Telescope Circuit

### Telescope Circuit

Cause	Remedy
<b>Telescope Function Only - Will Not Operate</b>	
Load too high.	Move lever to first position, not "high speed". Reduce load or set boom length before lifting load.
Both port relief valves sticking.	See section on "Relief Valves".
Hose plugged or liner collapsed.	Replace hose.
<b>Boom Extension Jerky or Erratic</b>	
Inadequate grease on boom pad surfaces.	Lubricate boom where pads contact boom.
Wear pads damaged.	Replace wear pads.
Wear pads shimmed to boom too tight.	Reshim wear pads.
Faulty counterbalance valve.	Replace counterbalance valve.
Loose chain system.	Adjust chains as required.
<b>Telescope Cylinder Extends But Will Not Retract</b>	
Port relief valve sticking.	See section on "Relief Valves".
Hold valve malfunctioning.	Repair or replace.
Internal leakage in cylinder.	See section on " <a href="#">Cylinder Leakage</a> ".
Extend valve malfunctioning.	Repair or replace.
<b>Boom Sections Retract Under Load</b>	
O-rings around hold valve damaged.	Replace O-rings.
Hold valve not seating properly.	Repair or replace.
Telescope cylinder by-passing.	See section on " <a href="#">Cylinder Leakage</a> ".

**Winch Circuit**

Cause	Remedy
<b>Winch Will Not Develop Maximum Line Pull</b>	
Main relief valve is set too low.	Readjust the main relief.
Main relief valve is sticking.	See section on "Relief Valves".
Winch motor worn excessively or damaged.	See section on "Fluid Motor".
Piston pump worn excessively or damaged.	See section on "Pumps".
Rotary manifold leaking internally.	Reseal rotary manifold.
Low oil level.	Add oil as required.
<b>Winch Will Lower But Will Not Raise</b>	
The sprag clutch is assembled backwards.	Ensure the winch is assembled properly.
Insufficient parts of line for the load being lifted.	See the reeving diagram on the capacity chart.
<b>Winch Will Raise But Will Not Lower</b>	
The winch hold valve is mounted on the winch motor incorrectly.	Ensure the winch is assembled properly.
The winch hold valve spool is sticking.	Repair or replace.
The winch brake is not releasing.	Ensure the brake release line is open. If necessary, disassemble and inspect the brake components.
Winch brake piston O-ring damaged.	Replace O-ring.
<b>Winch Will Not Hold Load (Load Drifts Down)</b>	
System back pressure too high.	Warm oil: check for restriction in downstream flow.
The over-running sprag on the brake is broken.	Inspect and replace, if necessary.
The automatic brake is not applying.	Ensure the winch brake release line is not plugged, and no foreign objects are in the brake assembly.
The winch brake friction plates are worn.	Replace friction plates.
<b>Winch Chatters When Lowering</b>	
The winch hold valve is set wrong or is malfunctioning.	Check the hold valve setting. If the winch continues to chatter, the holding valve is sticking. Inspect it for worn or damaged seals or contamination.

## 50-155 M & U

### Troubleshooting Outrigger Controls

#### Outrigger Controls

With the electrically controlled valves on the outriggers, two spools must be checked, the extend and retract valves in the diverter valve. The function valves are in 2 sectional valves - one for the front outriggers and one for the rear outriggers.

To operate an outrigger cylinder, the extend valve or the retract valve, plus a function valve must be shifted by the solenoids. If pressure is not detected at the pressure tap on the diverter valve, see the electrical troubleshooting section for verifying the operation of the solenoids.

#### Outrigger Circuit

Cause	Remedy
<b>All Outriggers Inoperative</b>	
Electrical malfunction.	See section on <a href="#">"Electrical Controls"</a> .
Outrigger relief valve malfunctioning.	See section on <a href="#">"Relief Valves"</a> .
Outrigger diverter valve malfunctioning.	Repair or replace.
Line to or from pump plugged or liner collapsed.	Clear blockage or replace hose.
Low oil level.	Add oil as required.
Gear pump worn or damaged.	See section on <a href="#">"Pumps"</a> .
<b>Individual Outrigger Inoperative</b>	
Electrical malfunction.	See section on <a href="#">"Electrical Controls"</a> .
Cylinder leaking internally.	See section on <a href="#">"Cylinders"</a> .
Hold valve on jack cylinder not operating.	Repair or replace jack cylinder hold valve.
Line plugged or collapsed between outrigger valve and cylinder.	Replace hose.
Beam wedged in extended position.	Extend jack far enough to pick up end of beam and retract. Replace slider pad block on top of outrigger box to pick up end of beams.
<b>Outriggers Will Not Lift Machine</b>	
Outrigger relief valve malfunctioning.	See section on <a href="#">"Relief Valves"</a> .
Outrigger diverter valve malfunctioning.	Repair or replace.
Outrigger pump is worn or damaged.	See section on <a href="#">"Pumps"</a> .
Cylinder by-passing.	See section on <a href="#">"Cylinders"</a> .
<b>Jack Cylinder Drifts Down (Out and Down)</b>	
Hold valve on top of malfunctioning cylinder.	Replace cartridge.
Thermal relief cartridge mounted in wrong end.	Check for proper assembly.
Cylinder by-passing.	See section on <a href="#">"Cylinders"</a> .

## Swing Pumps Circuit

Cause	Remedy
<b>Failure of Pump to Deliver Fluid</b>	
Pumps not engaged.	Engage pumps.
Low fluid level in reservoir.	Add recommended oil and check level.
Oil intake suction filter plugged.	Clean oil intake suction filter.
Air leak in suction line, preventing priming or causing noise and irregular action of control circuit.	Repair leaks in suction line.
Oil viscosity too heavy to pick up prime.	Use lighter viscosity oil. Follow recommendation for temperatures encountered.
Broken pump shaft or parts broken inside pump.	Contact your local distributor; if necessary, refer to the manufacturer's manual for the correct instructions in pump disassembly and repair.
<b>No Pressure in System</b>	
Pumps not engaged.	Engage pumps.
Pump not delivering oil for any of the reasons listed previously.	Follow remedies given previously.
<b>Relief valve not functioning due to:</b>	
Valve setting not high enough.	Increase pressure setting of valves.
Valve leaking.	Check seat for score marks and reseal.
Spring in relief valve broken.	Replace spring and readjust valve.
Internal leakage in control valves or cylinders.	To determine location, progressively block off various parts of circuit. When trouble is located, repair (Do not block between pump and relief valve).
<b>Relief valve not functioning due to:</b>	
Cold fluid.	Warm up system. Work with oil at recommended operating temperature range. See Operation section.
Air leak or restriction at inlet line.	Repair or clean inlet line.
Internal parts of pump are worn excessively.	Replace pump.

## 50-155 M & U

### Troubleshooting Swing Pumps Circuit

Cause	Remedy
<b>Pump Making Noise</b>	
Pump disconnect not engaged.	Shut engine off and engage pump disconnect.
Partially clogged intake line, intake filter or restricted intake pipe.	Clean out intake filter screen or eliminate restriction. Be sure suction line is completely open.
<b>Air leaks:</b>	
At pump intake pipe joints.	Test by pouring oil on joints while listening for change in sound of operation. Tighten as required.
Air drawn in through inlet opening.	Check and add oil to reservoir if necessary.
Air bubbles in oil.	Use hydraulic oil containing a foam depressant.
Too high oil viscosity.	Work only with oil at recommended operation temperature.
Oil intake suction filter plugged.	Clean the oil intake suction filter.
Rag, paper, etc., pulled into suction line or pump.	Remove all debris and matter from suction line or pump.
Worn or broken parts.	Replace broken or worn parts.
<b>External Oil Leakage Around Pump</b>	
Shaft seal worn causing oil to leak into gear drive housing.	Replace worn shaft seal.
Loose fitting on pump intake or discharge.	Keep all joints tight.
Damaged O-ring seals between pump sections.	Replace damaged O-ring seals.
Damaged O-ring at fittings.	Replace damaged O-ring at fittings.
<b>Excessive Wear</b>	
Abrasive matter in the hydraulic oil being circulated through the pump.	Clean suction filter and replace return filter. Drain and flush hydraulic system as necessary.
Viscosity of oil too low at working conditions.	Check oil recommendation.
Sustained high pressure above maximum pump rating.	Check relief valve setting.
Air recirculation causing chatter in system.	Check for air being drawn into system. Use hydraulic oil with a foam depressant.
<b>Breakage of Parts Inside Pump Housing</b>	
Excessive pressure above maximum pump rating.	Check relief valve setting.
Seizure due to lack of oil.	Check reservoir level, oil filter and possibility of restriction in suction line frequently.
Solid matter is wedged in pump.	Check suction line filter, drain and flush system as necessary.

## Swing Circuit Control Valves

Cause	Remedy
<b>Sticking Plungers</b>	
High oil temperature.	See section on <a href="#">"Excessive Heating of Oil in System"</a> .
Dirt in oil.	Change oil and oil filter. Clean system.
Fittings too tight.	Check torque.
Valve warped from mounting.	Loosen valve mounting bolts and check.
Excessive flow in valve.	Check to ensure that the hoses from pump are not crossed or reversed.
Linkage binding.	Free up linkage.
Plunger damaged.	Replace valve.
Return spring damaged.	Replace faulty parts.
Spring or detent cap binding.	Loosen cap, re-center and re-tighten.
Valve not at thermal equilibrium.	Let system warm-up.
<b>Leaking Seals</b>	
Paint on or under seal.	Remove and clean.
Excessive back pressure.	Open or enlarge line to reservoir.
Dirt under seal.	Remove and clean.
Scored plunger.	Replace valve.
Loose seal plates.	Clean and tighten.
Cut or scored seal.	Replace faulty parts.
<b>Unable to Move Plunger In or Out</b>	
Water frozen in plunger caps.	Remove caps to clean out.
Dirt in valve.	Clean and flush out.
Plunger cap full of oil.	Replace seals.
Bind in linkage.	Free up linkage.
<b>Load Drops When Plunger Moved from Neutral</b>	
Dirt in check valve.	Disassemble and clean.
Scored check valve poppet or seat.	Replace poppet or lap poppet to seat.
<b>Poor Hydraulic System Performance or Failure</b>	
Dirt in relief valve.	Disassemble and clean.
Relief valve defective.	See section on <a href="#">"Relief Valves"</a> .
Load too high.	Check line pressure.
Internal valve crack.	Replace valve.
Plunger not at full stroke.	Check movement and linkage.

## 50-155 M & U

Troubleshooting

Swing Circuit Control Valves

### Swing Circuit Control Valves

Cause	Remedy
<b>Unable to Obtain Pressure</b>	
Poppet stuck open or dirt under seal.	Check for foreign particles between poppets and their mating members. Members must slide freely.
<b>Erratic Pressure</b>	
Poppet seal damaged.	Replace damaged poppet parts and seals. Clean dirt and remove surface marks for free movement.
<b>Pressure Setting not Correct</b>	
Wear due to dirt. Lock nut adjustment screw loose.	See section on "Valve Adjustments".
<b>Leak</b>	
Damaged seals, worn O-rings, or parts sticking due to dirt.	Replace worn or damaged parts. Inspect for free movement of components. Check seats for scratches, nicks, or other marks.

**Fluid Motor**

Cause	Remedy
<b>Motor Will Not Turn</b>	
Pumps not engaged.	Engage pumps.
No oil.	Fill reservoir to proper oil level.
Pump broken.	Replace pump.
Relief valve stuck open or set too low.	Clean and free relief valve spool and adjust to proper setting.
Workload jammed or stuck.	Remove obstruction from workload.
Large contaminating foreign bodies in fluid.	Flush hydraulic system completely. Use new oil and install new filters.
<b>Slow Operation</b>	
Wrong oil viscosity.	Use proper viscosity oil.
Rotary manifold leaking.	Reseal rotary manifold.
Worn pump.	Repair or replace pump.
Extremely high fluid temperatures cause pump and motor to slip (temperature increases as pump and motor wear).	Add heat exchangers.
Relief setting too low.	Set relief valve for proper psi.
<b>Motor Turns in Wrong Direction</b>	
Hose connections wrong.	Reverse connections.
Wrong timing.	Re-time motor.
<b>Erratic Motor Operation</b>	
Relief valve pressure set too low.	Adjust relief valve setting.
Low oil level in reservoir permitting air to enter system.	Fill reservoir to proper level.
Air being "sucked in" on inlet side of pump.	Tighten fitting(s) on pump inlet side.
<b>Leak at Shaft</b>	
Worn or cut shaft seal.	Replace shaft seal.
<b>Leak Between Housing and Wear Plate or Between Wear Plate and Geroler Assembly</b>	
Motor housing bolts loose.	Clean mating surfaces and tighten nuts to appropriate value.
Pinched O-ring seal.	Replace.
<b>Leak at Oil Ports</b>	
Damaged seal or O-ring.	Replace O-ring or seal.
Poor fittings.	Replace fittings carefully.
Damaged threads.	Replace housing.

## 50-155 M & U

### Troubleshooting Cylinders

#### Cylinders

Cause	Remedy
<b>Cylinder Sticking or Binding</b>	
Damaged parts.	Repair or replace damaged parts.
Dirt or contamination.	Check oil condition. Check filters. Clean or replace filter elements. Change oil if condition requires it.
Loose parts.	Tighten cylinder rod eyes, if necessary. Check cylinder heads and tighten, if necessary.
Misalignment.	Check mounting pins and bushings. Tighten rod eyes.
<b>Erratic Action of Cylinders</b>	
Air in the system:	
Oil level is too low.	Add or change.
Air leak.	Locate and correct.
Foaming in reservoir.	Use hydraulic oil containing a foam depressant.
Internal leakage.	See section on " <a href="#">Cylinder Leakage</a> ".
Main Relief pressure too low or valve sticking.	See section on " <a href="#">Relief Valve</a> ".

## Cylinder Leakage

Hydraulic cylinders may retract due to the cooling of the oil in cylinder. Oil shrinks approximately 1% per 25°F of cooling. As an example, if a cylinder is extended 100" and cools 100°F, it will shrink 4".

### Telescope Cylinder

If excessive leak-down is encountered, check items in the following sequence:

1. With boom offside and horizontal, extend the boom approximately 6 ft. per section. Mark the first telescoping section at the end of the base section.
2. Elevate the boom to maximum angle and suspend a load on the hook.
3. With engine shut off, hold or tie the thumb wheel on the joystick in the full "extend" position for approximately 15 minutes.
4. Return the telescope thumb wheel joystick to neutral, start engine, ground the load, and return the boom to horizontal. Re-mark the boom section as in Step 1 above. Measure the distance between marks to determine leak-down of the cylinder.

The manufacturer's allowable drift specification for production machines is as follows:

With 14,300 lb. hook load, 2-part hoist line, boom extended about 6 ft. per section at maximum boom angle, and 160 degrees F. hydraulic oil temperature, the leak-down per cylinder is not to exceed 3/4 inch in a 15-minute period.

Identify a defective hold valve in the cylinder which drifts excessively by interchanging the hold valve cartridge with one removed from a cylinder that is not drifting, or by replacement with a new cartridge. Before installing the cartridge, visually inspect the external O-rings and backup washers. Retest per the procedure above to determine if hold valve was defective.

An alternate method to test the hold valve would be to disconnect the two hoses coming from the valve bank and then elevate the boom. If oil continues to flow slowly from the extend line, a hold valve problem exists. If oil continues to flow from retract, then it is faulty or leaking from the piston in cylinder.



With hollow rod telescope cylinders, in excess of 40 gallons of oil can be drained from the rod. If the boom comes in while doing this test, then the cylinder is faulty or leaking from the piston in the cylinder.

If the hold valve is not found defective, the cylinder must be removed from the boom assembly for repacking and checking. Perform an air test on the piston rod prior to reassembling the cylinder by blocking the retract ports on the rod near the piston end. Slip a plastic bag over the piston end of the rod and secure it with a rubber band. Apply and maintain a slight amount of air pressure at the rod's retract port (port marked with an "R"). Expansion of the plastic bag indicates a faulty rod weldment or seal on the rod's port tube.

When reassembling the cylinder, care should be taken to keep the piston rod assembly parallel in all planes with the cylinder barrel as the piston enters and is pushed down the barrel prior to gland engagement.

## 50-155 M & U

### Troubleshooting Cylinder Leakage



External leaks from telescope cylinders or hydraulic lines within the boom assembly do not cause leak-down unless one or more of the conditions listed above are present.

#### **Boom Lift Cylinder**

The suggested procedure for identifying the specific cause of leak-down should be performed in the following sequence:

1. Elevate the boom to near maximum angle, not completely extended, with a boom length sufficient to winch up a convenient payload approximately 1 ft. from ground level. Shut off engine.
2. Disconnect the extend hose, pilot drain hose, and the small pilot line hose at the holding valve ports and cap the pilot line hose and drain hose ends.
3. If hydraulic oil continues to run after the initial draining from either port of the hold valve as the hoist cylinder continues to leak down, the cause is within the hold valve.
4. If cylinder leak-down occurs with no oil leak from the hold valve ports, the cause is within the cylinder.

#### **Outrigger Jack Cylinder**

The suggested procedure for identifying the specific cause of leak-down is similar to the boom lift cylinder procedure:

1. Set the outriggers.
2. Elevate the boom to near maximum angle, not completely extended, with a boom length sufficient to winch up a convenient payload approximately 1 ft. from ground level. Shut off engine and remove pressure from the hydraulic reservoir by loosening the filler cap.
3. Disconnect the extend hose from the hold valve. This is a hose farthest away from the port tube and should have an "E" stamped next to it.
4. If hydraulic oil continues to run after the initial draining from the port of the hold valve as the jack cylinder continues to leak down, the cause is within the hold valve.
5. If cylinder leak-down occurs with no oil leak from the hold valve port, the cause is within the cylinder.
6. Do not start the engine until the hoses have been reconnected. The control valve spool is open-center to reservoir in the neutral position and return line oil would be pumped out.

## 50-155 M & U

Troubleshooting

Excessive Heating of Oil in System



### Excessive Heating of Oil in System

Cause	Remedy
<b>Heating Caused by Power Unit (Reservoir, Pump, Relief Valve, and Coolers)</b>	
Relief valve set at a higher or lower pressure than specified. Excess oil dissipated through increased slippage in various parts, or through relief valve.	Reset relief valve to recommended pressure.
Internal oil leakage due to wear.	Repair or replace faulty component.
Viscosity of oil too high or too low.	Follow recommendations for correct viscosity grade to be used.
Pumps assembled after overhaul may be assembled too tightly. This reduces clearances and increases rubbing friction.	Follow instructions when reassembling.
Leaking relief valves.	Repair.
Improper functioning of oil cooler.	Inspect cooler and see that it is working properly.
Improper machine operation.	Return control to neutral when stalled, cylinder at end of stroke, etc.
<b>Heating Because of Conditions in System</b>	
Restricted lines.	If lines are crimped, replace; if partially plugged for any reason, remove obstruction.
Internal leaks.	Locate leaks and correct.
Low oil level.	Check oil level and fill if necessary.

## 50-155 M & U

Troubleshooting  
Electrical Controls

### Electrical Controls

Cause	Remedy
<b>Electrical Failure</b>	
Rocker switch sticking.	Remove switch, check if hole is too tight. Cut out decal or file hole larger.
Tripped circuit breakers.	Reset breaker.
Disconnected or broken wires.	Replace or repair.
Open circuit.	Check with test light. Repair or replace.
Low voltage.	Check wires and grounds.
Poor engine solenoid connection.	Clean and tighten solenoid connection.
Defective solenoid.	Replace solenoid.
Solenoid failure.	Replace solenoid.
Poor ground connections.	Clean and tighten connections.

### Two-Block System

Cause	Remedy
<b>Panel light and horn will not come on with boom switch weight lifted (if equipped with disconnects, controls will not engage)</b>	
Burned out fuse.	Check and replace fuse (8 amp only).
Broken wire.	Check voltage in control panel between terminals #0 and #37. If 0 volts, check between ignition post of ignition switch and ground. If 12 volts available, wire to control panel is bad.
<b>Horn works, but no light with switch weight lifted (if equipped w/disconnects, controls will engage)</b>	
Light bulb burned out.	Replace bulb.

## Checklist and Inspection Forms

### Suggested Hydraulic Crane Inspection Checklist

This check list is to be used in addition to the information provided in this manual to properly operate and maintain the machine.

	<ol style="list-style-type: none"> <li>1. Indicate inspection result by checking in the satisfactory, adjust, or repair boxes provided.</li> <li>2. When appropriate, enter diagnosis on back of page for repairs or adjustments made.</li> </ol>
---	---

Inspection Code Intervals	D - Daily W - Weekly M - Monthly A - Annually P - Periodic Q - Quarterly			
Items to be Inspected and Checked	Inspection Code	Satisfactory	Adjust	Repair
* Visual inspection (Complete Machine)	D			
* Inspect overall machine (including carrier) for cracks, weld separation, leaks, damage, and vandalism.				
Hydraulic system (**Leaks or Damage)	D, A			
** Refer to Maintenance and Service section, <a href="#">"Hydraulic Hoses"</a> .				
Overall cleanliness	D			
Air system (Leaks or Damage)	D			
Hydraulic fluid	D			
Machine lubrication	D			
Attachment pin bolts	D			
All control mechanisms	D			
Instrument gauges	D			

## 50-155 M & U

### Checklist and Inspection Forms

#### Suggested Hydraulic Crane Inspection Checklist

Items to be Inspected and Checked	Inspection Code	Satisfactory	Adjust	Repair
Clutches and brakes	D			
Wire rope, sheaves, and guards	D			
Two block damage prevention system	D			
Load supporting components condition	D			
Fire extinguisher	D			
Backup alarm	D			
Boom angle indicator	D			
Horn	D			
Proper cable spooling	D			
Wedge sockets	D			
Drive shafts and U-joints	W			
Structural members and welds	Q			
Boom inspection	M			
Swing bearing bolt torque	W			
Machinery guards	Q			
Load chart and safety warnings	Q			

## 50-155 M & U

Checklist and Inspection Forms  
Daily Check (8 Hours)



### Daily Check (8 Hours)

Check Points	Status
Perform daily lubrication.	
Check hydraulic reservoir fluid level.	
Check hydraulic cylinder mounting bushings and pins.	
Check hydraulic components including hoses, refer to Maintenance and Service section, "Hydraulic Hoses".	
Check boom front slider pads.	
Check boom chains and ends.	
Check wire rope and related components.	
Check controls.	
Check instruments, gauges, lights, and safety equipment.	
Make overall visual inspection.	
Check anti-two-block system.	
Check Truck Manufacturer's Manual for additional maintenance requirements.	
Ensure swing brake is able to hold against full torque of swing motor.	

### Weekly Check (40 Hours)

Check Points	Status
Perform the daily check.	
Perform weekly lubrication.	
Check battery condition.	
Check hydraulic cylinders and rods.	
Make thorough inspection of wire rope.	
Check Truck Manufacturer's Manual for additional maintenance requirements.	
Clean machine weekly if salt-covered to prevent rust and corrosion.	

## 50-155 M & U

Checklist and Inspection Forms  
Monthly Check (80 hours)

### Monthly Check (80 hours)

Check Points	Status
Perform daily and weekly checks.	
Perform monthly lubrication.	
Check boom for wear cracked welds, alignment and missing or illegible decals.	
Check hydraulic reservoir for moisture.	
Check all slider pads.	
Have hydraulic oil sample analyzed.	
Check Truck Manufacturer's Manual for additional maintenance requirements.	

### Quarterly Checks (250 Hours)

Check Points	Status
Perform daily, weekly, and monthly checks.	
Perform quarterly lubrication.	
Drain fuel tank of water and sediment if necessary.	
Check brake shoes for wear condition.	
Change hydraulic return line filters.	
Check Truck Manufacturer's Manual for additional maintenance requirements.	
Lubricate valve disconnects.	
Clean and wax all exterior painted surfaces.	
Visually inspect all structural members and welds for cracks, alignment, and wear.	

## 50-155 M & U

Checklist and Inspection Forms  
Semiannual Checks (1000 Hours)



### Semiannual Checks (1000 Hours)

Check Points	Status
Perform daily, weekly, monthly, and quarterly checks.	
Perform semiannual lubrication.	
Check hydraulic reservoir relief valve.	
Clean hydraulic reservoir intake suction filter.	
Check air dryer desiccant for signs of oil accumulation.	
Check hydraulic relief valve pressure settings.	
Torque swing bearing bolts.	
Check Truck Manufacturer's Manual for additional maintenance requirements.	
Check all adjustments specified in the "Maintenance and Service" section of this manual and any vendor manuals supplied.	

### Annual Check (1500 - 2000 Hours)

Check Points	Status
Perform daily, weekly, monthly, quarterly, and semiannual checks.	
Perform annual lubrication.	
Disassemble winch and inspect.	
Drain and clean hydraulic reservoir.	
Change hydraulic fluid (unless checked by oil analysis).	
Drain and refill the winch lubricant.	
Check the hose lines, refer to Maintenance and Service section, "Hydraulic Hoses".	





**PAGE INTENTIONALLY LEFT BLANK**

## Appendix

### General Bolt Torque Values

Head Type	Hardware		A (K=0.12) (ft-lbs)	B (K=0.15) (ft-lbs)	C (K=0.17) (ft-lbs)	D (K=0.20) (ft-lbs)
Socket Head	1/4"-20	.25"	-	9	10	12
	5/16"-18	.3125"		19	22	26
	3/8"-16	.375"		35	40	48
	7/16"-14	.4375"		55	65	75
	1/2"-13	.5"		85	100	115
	5/8"-11	.625"		170	190	230
	3/4"-10	.75"		310	350	410
	7/8"-9	.875"		500	570	670
	1"-8	1"		760	860	1000
	1-1/4"-7	1.25"		1450	1650	1940
1-1/2"-6	1.5"	2530	2870	3375		

Hex Head – Grade 8	1/4"-20	.25"	6	7	9	10
	5/16"-18	.3125"	13	17	19	22
	3/8"-16	.375"	24	30	35	40
	7/16"-14	.4375"	40	50	55	65
	1/2"-13	.5"	55	70	80	90
	5/8"-11	.625"	120	150	170	200
	3/4"-10	.75"	210	270	310	370
	7/8"-9	.875"	350	440	500	590
	1"-8	1"	535	670	760	900
	1-1/4"-7	1.25"	1035	1290	1465	1725
	1-3/8"-6	1.5"	1355	1675	1920	2260
1-1/2"-6	1.5"	1800	2250	2550	3000	

#### Coefficient of Friction for Torque Values

A – Super Slick – 0.12 friction coefficient when Fastenal’s EcoGuard is coated on nut, bolt, and washer.

B – Slick – 0.15 friction coefficient for zinc plated, EcoGuard, MAGNI, etc., if lubricated in any way (wet torque).

C – Semi Dry – 0.17 friction coefficient if some form of anti-seize or thread lockers are used with otherwise plain conditions.

D – Dry – 0.20 friction coefficient for zinc plated, etc., wiped DRY of any form of lubrication (dry torque).



Dry indicates hardware has been cleaned and dried with some form of grease remover, solvent, and dry cloth. This table is for standard coarse thread. Ask engineering for torque values for fine threaded or other unique hardware.

# 50-155 M & U

## Appendix

### Hydraulic Fitting Torque Values

## Hydraulic Fitting Torque Values



Torque values within +/-5%. All torque values in foot-pounds. Use appropriate calibrated torque tools.

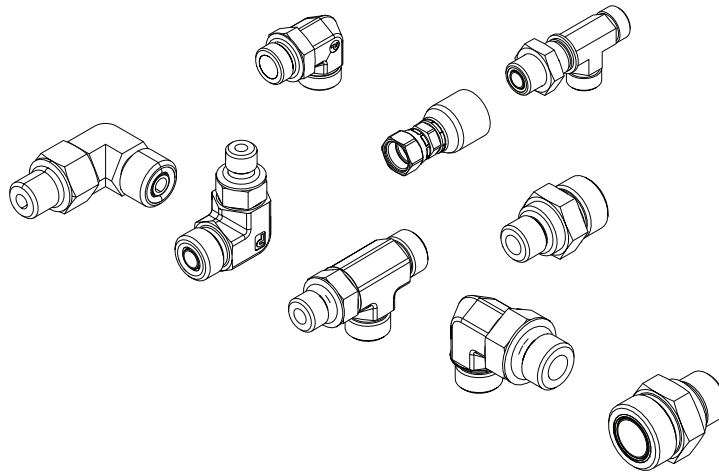

Port Size SAE Dash No.	Steel Ports	Aluminum Ports	Hose to Fitting and Fitting to Fitting	
	ORB Fittings O-Ring Boss (ft-lbs)	ORB Fittings O-Ring Boss (ft-lbs)	O-Ring Face Seal OFS (ft-lbs)	37 Deg Flare JIC (ft-lbs)
-4	18	15	15	15
-6	30	25	25	25
-8	60	40	40	40
-10	90	60	60	60
-12	135	85	85	85
-16	200	110	110	110
-20	250	150	150	150
-24	305	200	200	200

### Hydraulic Flange Fitting Torque Values



Torque values within +/-5%. All torque values in foot-pounds. Use appropriate calibrated torque tools.

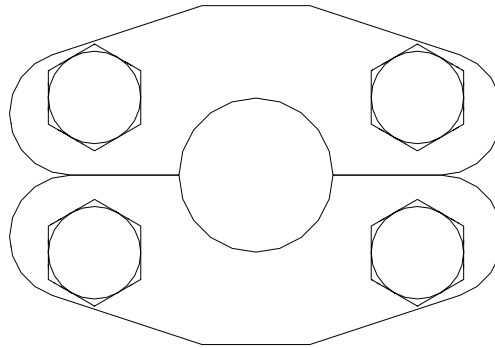

Code 61 (3000-5000 psi Max.)					
SAE Dash No.	Mounting hardware (in.)	Flange Size (in.)	Dimension B (in.)	Dimension E (in.)	Torque Steel (ft-lbs)
-8	5/16"-18 x 1.25	0.50	2.12	0.50	17
-12	3/8"-16 x 1.25	0.75	2.56	0.56	30
-16	3/8"-16 x 1.25	1.00	2.75	0.62	30
-20	7/16"-14 x 1.50	1.25	3.12	0.56	50
-24	1/2"-13 x 1.50	1.50	3.69	0.62	70
-32	1/2"-13 x 1.50	2.00	4.00	0.62	70
40	1/2"-13 x 1.75	2.50	4.50	0.75	70
-48	5/8"-11 x 1.75	3.00	5.31	0.88	110
-56	5/8"-11 x 1.75	3.50	6.00	0.88	110
-64	5/8"-11 x 2.00	4.00	6.38	1.00	110

Code 62 (6000 psi Max.)					
SAE Dash No.	Mounting hardware (in.)	Flange Size (in.)	Dimension B (in.)	Dimension E (in.)	Torque Steel (ft-lbs)
-12	3/18"-16 x 1.50	0.75	2.81	0.75	30
-16	7/16"-14 x 1.75	1.00	3.19	0.94	50
-20	1/2"-13 x 1.75	1.25	3.75	1.06	70
-24	5/8"-11 x 2.25	1.50	4.44	1.19	110
-32	3/4"-10 x 2.75	2.00	5.25	1.44	54-67

# 50-155 M & U

## Appendix Subframe Torque Values

### Subframe Torque Values



This chart is for lubricated hardware (plain, plated or coated). Torque values within +/-5%. All torque values in foot-pounds. If there are no frame stiffeners used, then maximum torque of 180 ft-lbs is allowed on installation hardware compressing frame.

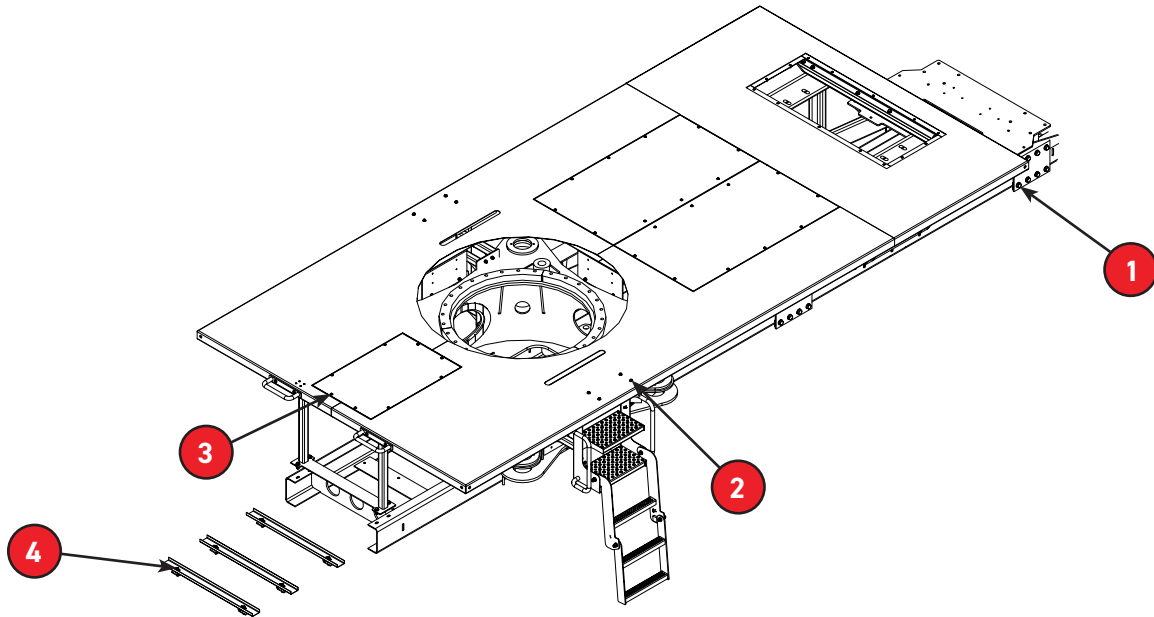

Sl No.	Location	Fastener	Clamping Torque
1	Shear Plate Bolts	3/4"-10 UNC	270 ft-lbs
2	Ladder MTG Bolts	3/8"-16 UNC	50 ft-lbs
3	Decking Bolts	5/16"-18 UNC	25 ft-lbs
		1/2"-13 UNC	70 ft-lbs
4	Rear Decking MTG Bolts	5/8"-11 UNC	150 ft-lbs

**Swing Bearing Torque Values**



Torque values within +/-5%. All torque values in foot-pounds. Use appropriate calibrated torque tools. Ensure star pattern is followed for even tightening. Torque to half rating on first round and fully torque in second round.

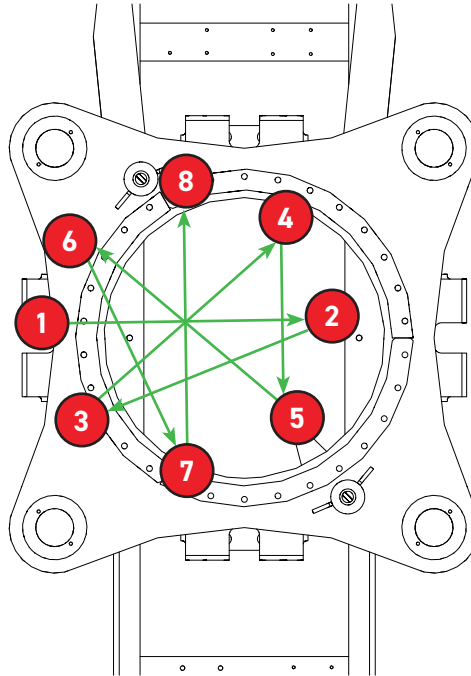

Crane Model	Hardware	Head Type	A (K=0.12) (ft-lbs)	B (K=0.15) (ft-lbs)	C (K=0.17) (ft-lbs)	D (K=0.20) (ft-lbs)
<b>50-155</b>	7/8"-9 UNC	Ferry Cap (12 Point)	-	500	570	670

Refer to the "Coefficient of Friction for Torqu Values", cleaned with some form of grease remover or solvent and dried with a cloth.

## 50-155 M & U

Appendix

Swing Drive Torque Values

### Swing Drive Torque Values



Torque values within +/-5%. All torque values in foot-pounds. Use appropriate calibrated torque tools.

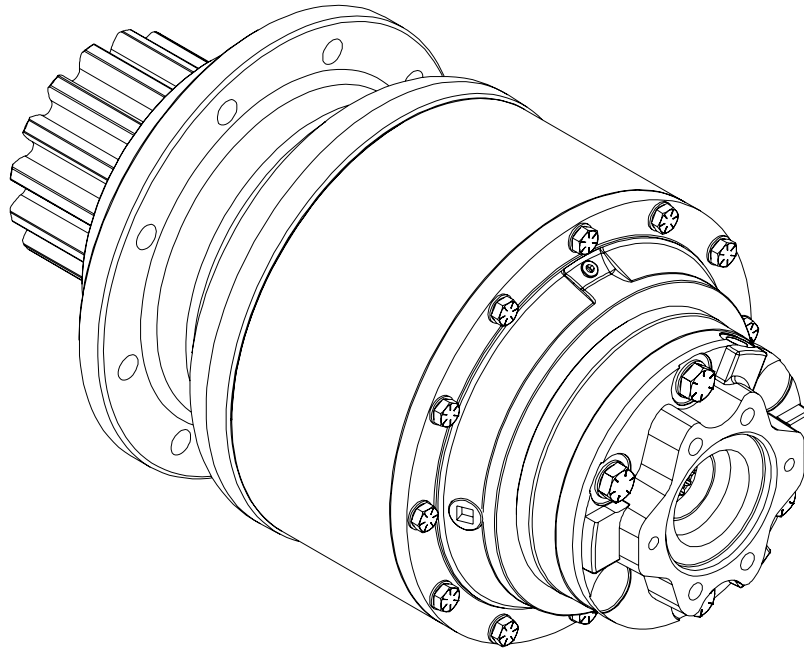

Crane Model	Hardware	Head Type	A (K=0.12) (ft-lbs)	B (K=0.15) (ft-lbs)	C (K=0.17) (ft-lbs)	D (K=0.20) (ft-lbs)
50-155	9/16-12	Stud - Grade 8	80	100	120	140

Refer to the "[Coefficient of Friction for Torque Values](#)".

# 50-155 M & U

Appendix

Winch Mounting Torque Values

## Winch Mounting Torque Values



Torque values within +/-5%. All torque values in foot-pounds. Use appropriate calibrated torque tools.

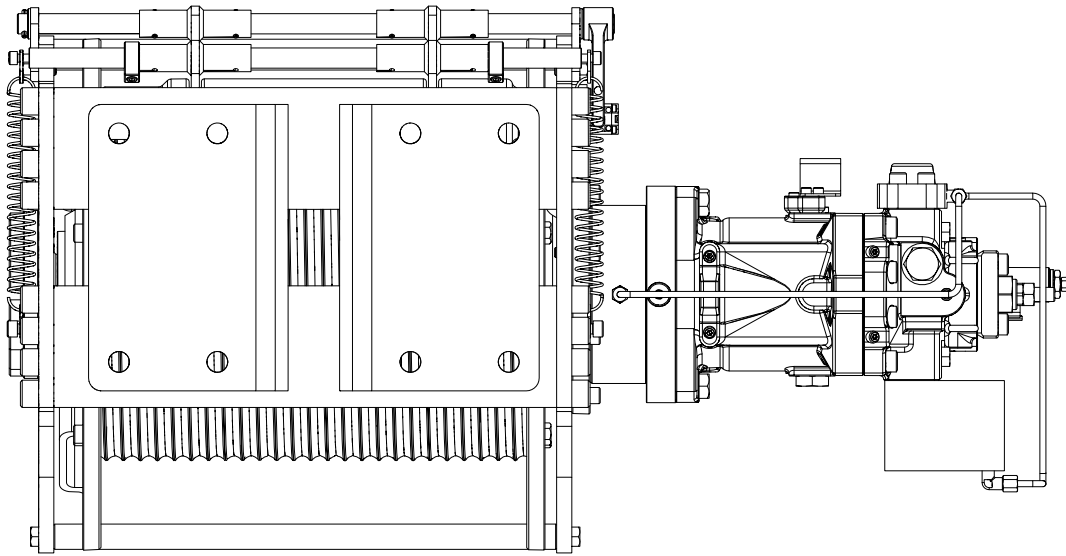

Crane Model	Hardware	Head Type	A (K=0.12) (ft-lbs)	B (K=0.15) (ft-lbs)	C (K=0.17) (ft-lbs)	D (K=0.20) (ft-lbs)
50-155	3/4"-10 UNC	Hex Head - Grade 8	210	270	310	370

Refer to the ["Coefficient of Friction for Torque Values"](#).

# 50-155 M & U

Appendix

Outrigger Jack Torque values

## Outrigger Jack Torque values



Torque values within +/-5%. All torque values in foot-pounds. Use appropriate calibrated torque tools.

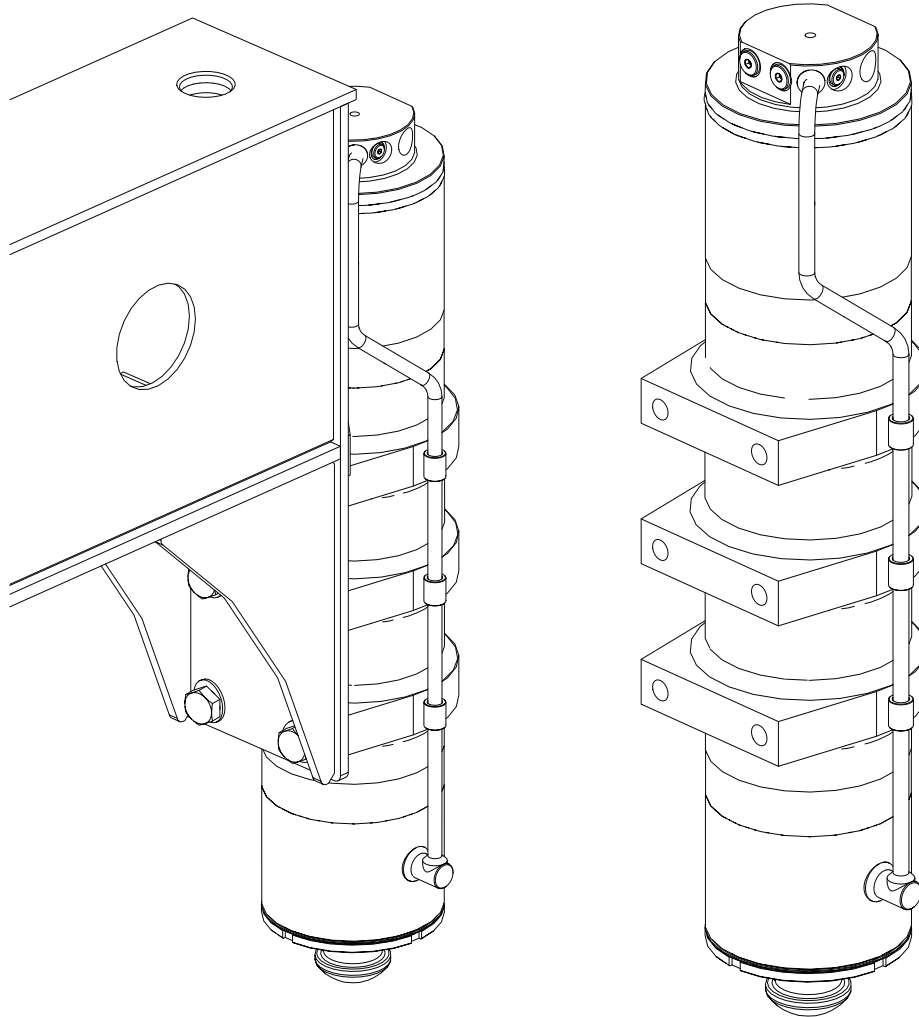

Crane Model	Hardware	Head Type	A (K=0.12) (ft-lbs)	B (K=0.15) (ft-lbs)	C (K=0.17) (ft-lbs)	D (K=0.20) (ft-lbs)
50-155	7/8"-9 UNC	Hex Head - Grade 8	350	440	500	590

Refer to the ["Coefficient of Friction for Torque Values"](#).

## 50-155 M & U

Appendix

Greer Insight Operator's Manual



### Greer Insight Operator's Manual

The **Load King** crane is set up with a Greer Insight Load Moment Indicator (LMI) system. This manual is included in the accompanying flash drive.





[www.loadkingmfg.com](http://www.loadkingmfg.com)

**Load King**

7701 Independence Ave,  
Kansas City, MO 64125  
Parts: (816) 241- 8387  
Service: (833) 281-7911  
Email: [info@loadkingmfg.com](mailto:info@loadkingmfg.com)



# 50-155 M & U | Operator's Manual